

**APPENDIX G**

**PRELIMINARY WATER QUALITY MANAGEMENT PLAN AND  
HYDROLOGY REPORT**

**This page intentionally left blank**

**Preliminary  
Water Quality Management Plan  
(WQMP)**

**for:**

**SOUTH SHORES CHURCH**

**South Shores Church  
32712 Crown Valley Parkway  
Dana Point, CA 92629  
(949) 496-9331**

**CUP NO. 04-21 / SDP 04-31 / CDP 04-11 AND V04-11**

**Prepared for:**

**South Shores Church  
32712 Crown Valley Parkway  
Dana Point, CA 92629  
(949) 496-9331**

**RECEIVED**

**DEC 04 2012**

**CITY OF DANA POINT  
COMMUNITY DEVELOPMENT  
DEPARTMENT**

**Prepared by:**

**Adams-Streeter Civil Engineers, Inc.  
Nicholas A. Streeter, PE  
15 Corporate Park  
Irvine, CA 92606  
949.474.2330  
nstreeter@adams-streeter.com**

**Prepared:**

**November 21, 2012**

**RECEIVED**

**CITY OF DANA POINT  
COMMUNITY DEVELOPMENT  
DEPARTMENT**

## Owner's Certification Water Quality Management Plan (WQMP)

**Project Name:** South Shores Church Master Plan  
CUP NO. 04-21 / SDP 04-31 / CDP 04-11 AND V04-11

This Preliminary Water Quality Management Plan (WQMP) has been prepared for the South Shores Church Master Plan for South Shores Church by Adams-Streeter Civil Engineers, Inc. The WQMP is intended to comply with the requirements of the City of Dana Point's Local Implementation Plan and Storm Water /Surface Runoff Water Quality Ordinance, as well as the Municipal Separate Storm Sewer System (MS4) Permit, Order R9-2009-0002 which requires the preparation of a project WQMP for priority development projects.

The undersigned, while he/she/it owns the subject property, is responsible for the implementation of the provisions of this WQMP. The undersigned will ensure that this plan is carried out and amended as appropriate to reflect up-to-date conditions on the site consistent with the current City of Dana Point Local Implementation Plan and the intent of Order R9-2009-0002, as authorized by the State and EPA, into perpetuity. Once the undersigned transfers its interest in the property, its successors-in-interest shall bear the aforementioned responsibility to implement and amend the WQMP, as necessary. An appropriate number of approved and signed copies of this document shall be available on the subject site in perpetuity.

This WQMP will be reviewed with the facility operator, facility supervisors, employees, tenants, maintenance and service contractors, or any other party having responsibility for implementing portions of this WQMP.

Signed: \_\_\_\_\_ Date: \_\_\_\_\_

Name: G.G. Kohlhagen

Title: Building Committee Chairman / Church Project Manager

Company: South Shores Church

Address: 32712 Crown Valley Parkway, Dana Point, CA 92629

Telephone #: 714-404-4962

Email Address: ggkohlhagen@cox.net

## Table of Contents

<b>1.0</b>	<b>Project Description .....</b>	<b>1</b>
<b>2.0</b>	<b>Project Location Map.....</b>	<b>4</b>
<b>3.0</b>	<b>Project Site Assessment .....</b>	<b>5</b>
<b>4.0</b>	<b>Pollutants of Concern.....</b>	<b>8</b>
<b>5.0</b>	<b>Hydromodification/Hydrologic and Geotechnical Conditions of Concern/Drainage Report.....</b>	<b>11</b>
<b>6.0</b>	<b>LID, Site Design, Source Control &amp; Treatment Best Management Practices (BMPs) .....</b>	<b>17</b>
<b>6.1</b>	<b>LID/Site Design BMPs .....</b>	<b>17</b>
<b>6.2</b>	<b>Source Control BMPs .....</b>	<b>18</b>
<b>6.3</b>	<b>Treatment Control BMPs .....</b>	<b>26</b>
	<b>6.3.1 Selection .....</b>	<b>29</b>
	<b>6.3.2 Sizing.....</b>	<b>49</b>
	<b>6.3.3 Location .....</b>	<b>81</b>
	<b>6.3.4 Restriction on Use of Infiltration BMPs.....</b>	<b>81</b>
<b>7.0</b>	<b>Project Plan and BMP Location Map.....</b>	<b>56</b>
<b>8.0</b>	<b>Stormwater BMP Maintenance.....</b>	<b>83</b>
	<b>8.1 Operation and Maintenance (O&amp;M) Plan.....</b>	<b>83</b>
	<b>8.1.1 Responsible Party.....</b>	<b>83</b>
	<b>8.1.2 Record Keeping.....</b>	<b>83</b>
	<b>8.1.3 Vector Control .....</b>	<b>84</b>
	<b>8.1.4 Required Permits.....</b>	<b>84</b>
	<b>8.1.5 Inspections .....</b>	<b>84</b>
	<b>8.1.6 Operation and Maintenance Requirements .....</b>	<b>84</b>

**Tables**

**4.1 Potential Pollutants for Project Categories ..... 10**

**6.1 Routine Non-Structural BMPs..... 19**

**6.2 Treatment Control BMPs..... 28**

**Figures**

**2.1 Location Map/Aerial Photo..... 4**

**7.1 Project Plans and BMP Location Map..... 56**

**Appendices**

- A Educational Material Resources**
- B Drainage Study**
- C Geotechnical Study**
- D LID/Treatment BMP Design Calculations**
- E BMP Operation & Maintenance Checklist & Training Logs (in final design)**
- F WQMP Annual Verification Form (in final design)**

## Section 1 Project Description

### 1. Detailed development description:

The South Shores Church is a hilltop property located on the east side of Crown Valley Parkway, approximately a quarter-mile from its intersection with Pacific Coast Highway, in the City of Dana Point, California, as shown in the Location Map (Figure 2.1, Page 3).

The subject site is bounded at the west by Crown Valley Parkway, at the south by an existing residential community, and at the north by a descending graded cut slope and a vacant area within an existing apartment complex. At the east boundary, a large, natural slope descends to a graded area with a portion of a golf course and a bike path near the toe-of-slope. Salt Creek runs along the adjacent natural basin through the golf course below, and under Pacific Coast highway to drain to the ocean.

The proposed redevelopment of the subject site will include phased demolition of the existing preschool, chapel, and administration/fellowship hall. Ground improvement in the form of mechanical slope stabilization will be undertaken at the northeast portion of the site, and several new buildings and retaining walls will be constructed. New buildings will be constructed to the south and north of the existing Sanctuary, which will remain. The new buildings will consist of a new Preschool/Administration Building with a Landscaped Garden to the south of the Sanctuary, and two, new Christian Education Buildings and a Community Life Center to the north of the Sanctuary. The proposed buildings are two-story structures, to be set into gently variable topography with the use of interior and exterior retaining walls. Parking areas and access pathways will be reconfigured with relatively minor cut and fill grading, and a second-story parking deck is proposed for a portion of the parking area, with the lower level partially subterranean.

Per Table 7.1 of Section 7 of the City of Dana Point's Local Implementation Plan, the proposed redevelopment project meets the criteria of a priority project by adding, or replacing, at least 5,000 or more square feet of impervious surface.

To comply with the project's EIR, an alternate design has been considered for the project in which footprints of proposed buildings have decreased. In this case, the alternate plan will incorporate the same BMP concept as the proposed version. The alternate will differ by decreasing impervious area, thus improving water quality.

### 2. Project location and site address, APN & GIS coordinates:

32712 Crown Valley Parkway, Dana Point, California  
 APN 670-181-02  
 GIS Coordinates: 33°29'16"N, 117°43'17"W

### 3. Property size:

Parcel Size: 6.00 Acres (261,497 square feet)  
 Proposed Development: 5.1± Acres (221,675± square feet)

### 4. Existing use:

The site has been previously developed and is occupied by a sanctuary building, preschool and supporting facilities and surface parking facilities. There is permanent landscaping throughout the site consisting of trees and shrubs including native type vegetation along the manmade and natural slope that bounds the site along the easterly property boundary.



**5. Impervious/pervious surface areas:****Existing Condition**

Impervious Surface Area: 3.26 acres (142,093 sq. ft.) – **54%**

Pervious Surface Area: 2.74 acres (119,404 sq. ft.) – **46%**

**Developed Condition**

Impervious Surface Area: 4.51 acres (196,486 sq. ft.) – **75%**

Pervious Surface Area: 1.49 acres (65,011 sq. ft.) – **25%**

The impervious surface area will increase from 54% of the site to 75% of the site. This represents an **increase** of impervious surface area by **38%**.

**6. Property ownership:**

The site is a private property owned by South Shores Church.

**7. Other:**

The South Shores Church Master Plan is a multi-phased project. This Preliminary WQMP is intended to be revised and updated for each phase of work before the issuance of grading permits.

## Section 2 Project Location Map/Aerial Photo

The location of the project site is illustrated in **Figure 2.1**.

**Figure 2.1**

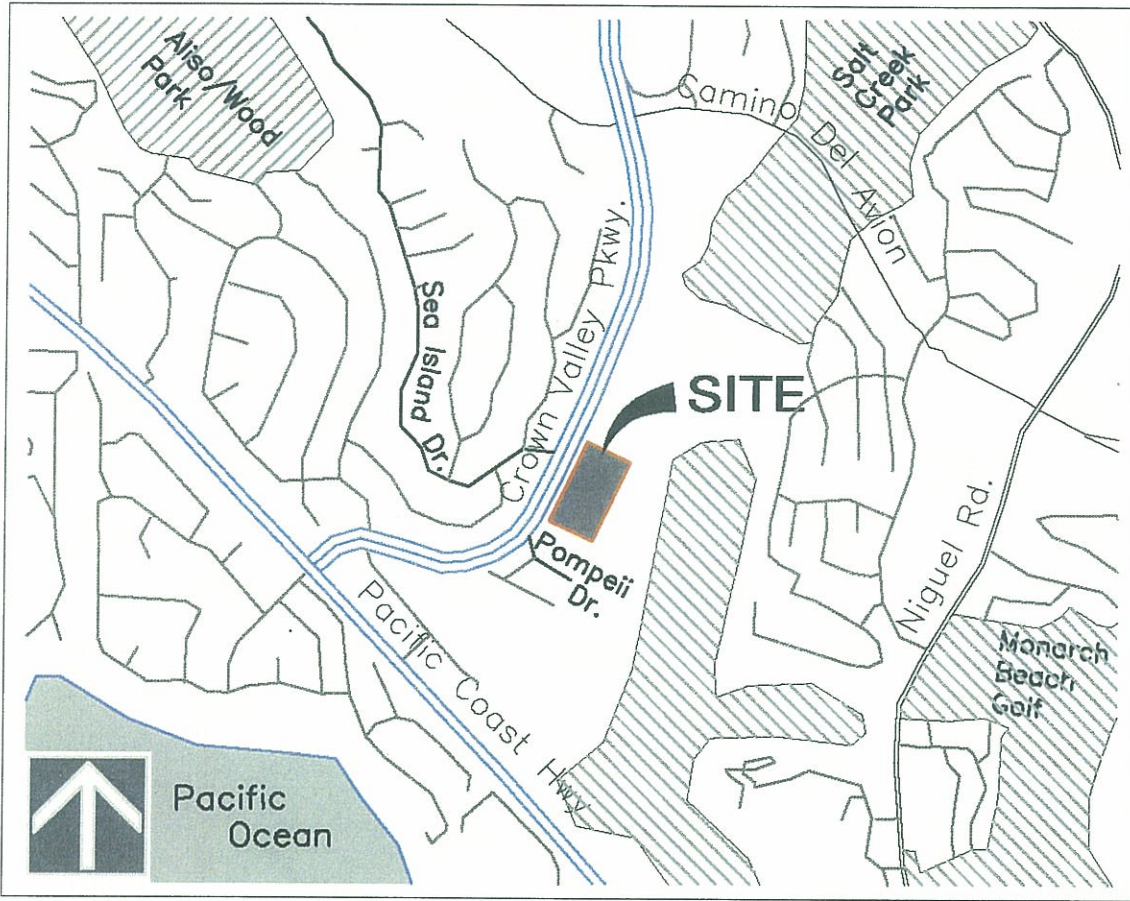

### VICINITY MAP

## Section 3 Project Site Assessment

This project site assessment section provides important information that is used when considering the potential water quality and hydrologic impacts that could be caused by the proposed project. This information is important when considering and selecting the appropriate BMPs to reduce identified potential impacts as well as when developing measures to reduce those impacts.

### 1. Zoning and land use designation:

City of Dana Point Zoning Designation is Community Facility

### 2. Existing and proposed drainage:

Existing Condition: The project site drains in a south-easterly direction, away from Crown Valley Parkway. Approximately 3.25 acres of the site drain to the south-east corner of the property into an existing man-made drainage basin. Of the 3.25 acres, the existing parking lot drains to an existing catch basin via sheet flow and then enters into an underground storm drain before discharging onto a concrete channel which then enters the drainage basin. The remainder of the 3.25 acres enters the underground storm drain system at various points before discharging into the drainage basin. The existing drainage basin discharges to an existing concrete v-ditch that runs south towards Pointe Monarch Community.

The balance of the property drains via sheet flow or multiple drainage pipes towards the existing slope on the east side of the property. There is also a small area, consisting of driveway and landscaping, that drains towards Crown Valley Parkway.

Proposed Condition: The developed condition of the project site consists of four drainage patterns. The majority of the proposed site, Area "A", will drain to an underground storm drain system. Area "A"s water quality will be improved through the use of roof drain planter boxes, proprietary bio-filters, such as Filterra Systems, and bio-filtration swale / depressed landscape. To reduce peak flows, flows from Area "A" will enter an on-site detention system, consisting of a pretreatment CDS Unit and underground detention system, which operates as a short-term holding tank to reduce peak flows. The underground detention system will consist of a steel-reinforced polyethylene pipe network, which will control peak discharge flows with a restrictor plate. Reduction of the site's peak discharge is not only necessary due to the increase of impervious area, but also because of the elimination of the off-site drainage basin. After flows leave the on-site detention system, the proposed storm drain pipe will discharge directly into the existing concrete v-ditch, bypassing the existing drainage basin to be eliminated.

Area "B" will enter the proposed storm drain pipe downstream of the on-site detention system before discharging into the existing concrete v-ditch. Area "B"s water quality will be improved through the use of roof drain planter boxes, storm water planters and proprietary bio-filters, such as Filterra System.

Area "C" consists of existing vegetation that will drain via an existing concrete v-ditch on the site's southerly property line. It will ultimately connect to the existing v-ditch and converge with flows from Area "A" and "B".

The fourth drainage pattern, Area "D", consists of natural slopes that sheet flow to the east.

The final drainage pattern, Area "E", consists of a portion of driveway entrances and sidewalk that sheet flow towards Crown Valley Parkway.

No off-site runoff occurs.

See Drainage Exhibits in Appendix B for drainage area analysis.

**3. Hydromodification Criteria: Does the project drain to a natural bottom creek, such as Salt Creek or San Juan Creek?**

No, the proposed project discharges into an existing concrete v-ditch at the south corner of the property. Flows within the concrete v-ditch travel south towards the Pointe Monarch community (Tract No. 14605) and enters into a man-made drainage basin. From the basin, flows travel south-east via a RCP storm drain pipe, which connects to a concrete box culvert (O.C.F.C.D. facility No. K01) at the north side of Pacific Coast Highway and the bottom of Salt Creek. Flows then travel within the concrete box culvert underneath Pacific Coast Highway and enter the Salt Creek Ozone Treatment Plant before discharging directly to the Pacific Ocean. See "Path of Discharge" Exhibit below for detailed path of travel.

**4. Watershed:**

Pacific Ocean – via municipal storm drain system.

**5. 303(d) listed receiving waters, TMDLs & ESAs:**

Per the 2010 303(d) Integrated Report, the following ESA waterbodies impacted by this project are on the 303(d) List for the impairments indicated and applicable TMDLs:

- Salt Creek at Pacific Ocean, Total Coliform, TMDL

The bacteria TMDL for Beaches & Creeks was adopted in December 2007.

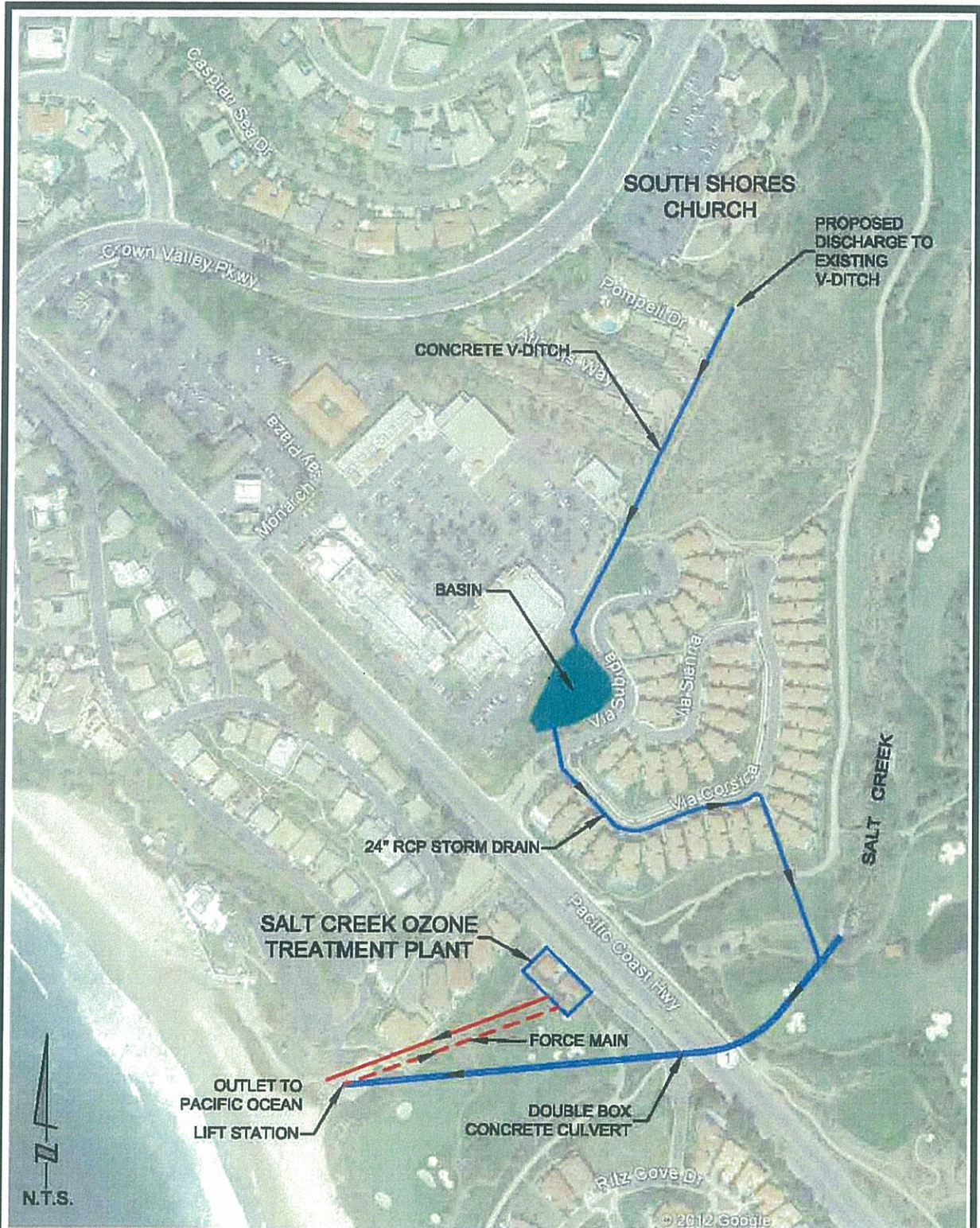

### PATH OF DISCHARGE EXHIBIT

SOUTH SHORES CHURCH  
DANA POINT, CA

## Section 4 Pollutants of Concern

This section of the WQMP identifies primary pollutants of concern. Pollutants of concern are those that are anticipated to be generated by the proposed project. Primary pollutants of concern are dependent upon impairments in the downstream receiving waters. If the project will drain to a receiving water that is impaired for a pollutant anticipated from that project, that pollutant is a primary pollutant of concern. In some cases, there may be specific conditions (i.e. other known water quality problems) that warrant identifying additional pollutant(s) as a primary pollutant of concern.

### 1. Project categories and features and anticipated and potential pollutants:

#### Phase IA- Preschool/ Administration Building

BMPs to be Constructed:

- Underground Detention Basin
- PRE-1; CDS Unit
- BIO-1; Downspout Planter Boxes
- BIO-7; Filterra System

Potential Pollutants (Hillside development and commercial land use):

- Nutrients
- Pesticides
- Suspended Solids / Sediments
- Trash & Debris
- Oil & Grease
- Bacteria / Virus / Pathogens

#### Phase 1B- Demolition of existing buildings, Preschool, Administration & Fellowship Hall and Chapel

BMPs to be Constructed:

- See Phase IA

Potential Pollutants (Hillside development and commercial land use):

- Nutrients
- Pesticides
- Suspended Solids / Sediments
- Trash & Debris
- Oil & Grease
- Bacteria / Virus / Pathogens

#### Phase 1C- Community Life Center

BMPs to be Constructed:

- BIO-1; Downspout Planter Boxes at Community Life Center

Potential Pollutants (Hillside development and commercial land use):

- Nutrients
- Pesticides
- Suspended Solids / Sediments
- Trash & Debris
- Oil & Grease
- Bacteria / Virus / Pathogens

### **Phase 2- Christian Education, Building One**

BMPs to be Constructed:

- BIO-1; Downspout Planter Boxes
- BIO-7; Filterra System

Potential Pollutants (Hillside development and commercial land use):

- Nutrients
- Pesticides
- Suspended Solids / Sediments
- Trash & Debris
- Oil & Grease
- Bacteria / Virus / Pathogens

### **Phase 3- Christian Education Building Two**

BMPs to be Constructed:

- BIO-7; Filterra System

Potential Pollutants (Hillside development and commercial land use):

- Nutrients
- Pesticides
- Suspended Solids / Sediments
- Trash & Debris
- Oil & Grease
- Bacteria / Virus / Pathogens

### **Phase 4- South Half of Parking Structure**

BMPs to be Constructed:

- BIO-1; Storm Water Planter
- BIO-7; Filterra System

Potential Pollutants (Parking Lot Use):

- Heavy Metals
- Nutrients
- Pesticides
- Toxic Organic Compounds
- Suspended Solids / Sediments
- Trash & Debris
- Oil & Grease
- Bacteria / Virus / Pathogens

### **Phase 5-North Half of Parking Structure**

BMPs to be Constructed:

- BIO-2; Vegetated Swale
- BIO-7; Filterra System

Potential Pollutants (Parking Lot Use):

- Heavy Metals
- Nutrients

- Pesticides
- Toxic Organic Compounds
- Suspended Solids / Sediments
- Trash & Debris
- Oil & Grease
- Bacteria / Virus / Pathogens

<b>2.</b>	<b>Primary pollutant(s) of concern:</b> Total Coliform and Bacteria have been listed as a primary pollutant of concern.
<b>3.</b>	<b>Project water quality analyses:</b> See Section 6.3 and Appendix D

**Table 4.1 Potential Pollutants for Project Categories**

Priority Project Categories and/or Project Features	General Pollutant Categories							
	Heavy Metals	Nutrients	Pesticides	Toxic Organic Compounds	Suspended Solids/ Sediments	Trash & Debris	Oil & Grease	Bacteria/Virus/ Pathogens
Detached Residential Development	N	E	E	N	E	E	E	E
Attached Residential Development	N	E	E	N	E	E	E <sup>(2)</sup>	E
Commercial/ Industrial Development	E <sup>(4)</sup>	E <sup>(1)</sup>	E <sup>(1)</sup>	E <sup>(2)</sup>	E	E	E	E <sup>(3)</sup>
Automotive Repair Shops	E	N	N	E	N	E	E	N
Restaurants & Food Service Establishments	E <sup>(2)</sup>	E <sup>(1)</sup>	E <sup>(1)</sup>	N	E <sup>(1)(2)</sup>	E	E	E
Retail Gasoline Outlets	E	N	N	E	N	E	E	N
Hillside Development	N	E	E	N	E	E	E	E
Parking Lots	E	E <sup>(1)</sup>	E <sup>(1)</sup>	E	E	E	E	N
Streets, Highways & Freeways	E	E <sup>(1)</sup>	E <sup>(1)</sup>	E	E	E	E	N

E = expected to be of concern  
 N = not expected to be of concern

(1) A potential pollutant if landscaping or open area exist on-site, otherwise not expected.  
 (2) A potential pollutant if the project includes uncovered parking areas, otherwise not expected. (3) A potential pollutant if land use involves food or animal waste products, otherwise not expected.  
 (4) Expected if outdoor storage or metal roofs, otherwise not expected.



## Section 5 Hydromodification/Hydrologic and Geotechnical Conditions of Concern/Drainage Report

Hydromodification is the alteration of natural flow characteristics and sediment supply, which can result from new development and significant redevelopment projects without appropriate preventative controls. Common impacts to the hydrologic regime resulting from development include increased runoff volume and velocity; reduced infiltration; increased flow frequency, duration, and peaks; and faster time to reach peak flow. Under certain circumstances, new development and significant redevelopment could also result in the reduction in the amount of sediment supplied to the channel for transport. If the sediment supplied to the channel is reduced such that in-stream flows are transporting sediment faster than it can be replenished, then erosion of the channel's bed and bank may occur. These changes have the potential to permanently impact downstream channels and habitat integrity. A change to a Priority Project site's hydrologic characteristics would be considered a condition of concern if the change would have a significant impact on downstream natural channels and habitat integrity. In determining whether an impact is significant, the cumulative effects on the watershed must be considered.

The first step to determine whether or not hydromodification requirements apply is based on the proposed Project's location and point of discharge. All PDPs must meet the hydromodification requirements unless:

- the project site discharges into an underground storm drain system that discharges direct to a bay or ocean; or
- the project site discharges into a conveyance channel whose bed and bank are concrete lined all the way from the point of discharge to ocean waters, enclosed bays, estuaries or water storage reservoirs and lakes.

Based on the project's location and point of discharge, See Path of Discharge Exhibit on Sheet 6, this project is not subject to the Hydromodification Criteria.

### 1. Topography, soil type and vegetation:

The project site is located on a hillside with variable slopes ranging from minor to moderate.

The project site has soil with hydrologic classifications of principally Type "D".

The existing slope on the south-easterly side of the property is comprised of grass, shrubs, and trees. The remainder of the site contains landscaped areas that are regularly maintained.

### 2. Drainage features:

Drainage features include catch basins, an underground detention system, RCP storm drain pipes, concrete v-ditches, an above ground drainage basin, and a concrete box culvert. See Hydromodification Exhibit.

**3. Relevant hydrologic and environmental factors:**

The project site, project's vicinity, adjacent properties or areas downstream of the site are not prone to flooding or have erosion problems.

Sensitive biological areas potentially exist to the east of the subject property in the form of coastal sage scrub, which may be a potential habitat for the endangered California gnatcatcher.

**4. Proposed hydrologic conditions:**

The proposed development will increase the amount of impervious surface area, which will reduce infiltration. But, with the use of an underground detention system located under a portion of the project site's parking lot, runoff volume and flow will not be increased. Proposed development's peak flows will match existing condition flows minus the flows detained from the existing off-site drainage basin, which is to be eliminated.

The proposed development's underground detention system will increase storage volume to not only account for the elimination of the off-site basin, but also for the increased impervious surface area. This underground detention system will be comprised of two 84" pipes with a restrictor plate at its outlet, which temporarily holds water while slowly being released.

**5. Significant impact on downstream channels and habitat integrity:**

The developed condition's peak discharge will be decreased. Runoff from impervious areas will discharge to an off-site v-ditch that leads to a basin, then flows into an underground storm drain to the Salt Creek Ozone Treatment Facility before discharging into the Pacific Ocean.

**6. Project hydrology analyses:**

The temporary basin was designed to decrease peak flows coming from the property to the original flows that occurred before the construction of the main sanctuary building. These original flows were calculated in the Hydrology and Hydraulic Report for South Shores Baptist Church, prepared by David A. Boyle Engineering on January 10, 1991. The hydrology report calculated that the 100-year peak flow being discharged by the property and outletting at the south-east corner was equal to 12.33 cfs. This accounted for approximately 3.2 acres of the property's total 6.0 acres. The report also included calculations that proved the existing concrete v-ditch, which is the ultimate conveyance structure, was able to meet capacity. See Appendix B for original calculations prepared by Boyle Engineering.

In its ultimate condition the project will be developed as shown on the Proposed Master Site Plan (Architectural Plan A3.0) which is included in the Appendix B. The majority of the proposed site, Area "A", is comprised of approximately 4.0 acres. To reduce peak flows, flows from Area "A" will enter a proposed underground detention system. This underground detention system will be comprised of two 84" pipes with a restrictor plate at its outlet. The location of the underground detention system is shown on the Developed Condition Hydrology Map. This proposed storm drain will continue to collect flows from Area "B" downstream of the detention system before discharging to the existing concrete v-ditch at the property's south-east corner. A discharge head wall and v-ditch connection will have to be constructed to properly convey flows from Areas "A", "B", and "C" to the existing v-ditch.

The proposed underground detention basin will reduce the site's developed peak flow to match existing flows as calculated by the Boyle Engineering Hydrology report. The balance of the site that does not enter the storm drain system, shown as Area "D" is considered natural slope. These peak flows are reduced substantially, as shown in Table below. A copy of the Developed Condition Hydrology Map that shows the concept drainage system is included in the Appendix B.

HYDROLOGY SUMMARY - SOUTH-EASTERLY DISCHARGE POINT (AREAS "A", "B", & "C")		
FREQUENCY	EXISTING FLOW (CFS)	DEVELOPED FLOW (CFS)
Q-2	6.0	4.6
Q-5	8.6	6.2
Q-10	11.0	7.6
Q-25	13.1 / 9.6*	8.9
Q-100	16.8 / 12.3*	10.0

HYDROLOGY SUMMARY - EASTERLY EXISTING SLOPE (AREA "D")		
FREQUENCY	EXISTING FLOW (CFS)	DEVELOPED FLOW (CFS)
Q-2	4.2	1.3
Q-5	6.0	1.8
Q-10	7.7	2.4
Q-25	11.3	2.8
Q-100	14.3	3.6

*\*Flows refer to existing peak flows as calculated by the Hydrology Report prepared by Boyle Engineering.*

A drainage report was prepared for the proposed project by Adams-Streeter Civil Engineers, Inc., as required by the City, and is included as Appendix B. A summary of the drainage report is provided below.

A geotechnical report was also prepared for the proposed project by LGC Geotechnical, Inc., as required by the City, and is included as Appendix C.

## Hydrology Report Summary

### *EXISTING CONDITIONS*

The existing site of approximately 6.0 acres has been previously developed and is currently occupied by a preschool, administration / fellowship hall, chapel, sanctuary building with supporting surface parking facilities. There is permanent landscaping throughout the site consisting of trees and shrubs including native type vegetation along the man-made and natural slopes that bound the site along the easterly property boundary. The watershed is classified as a non-mountainous area. The slope of the existing site terrain is substantially uniform with the existing parking lot sloping at approximately 2.5% to 4%. The terrain behind the existing buildings on the easterly edge slopes at approximately 3 (horizontal) to 1 (vertical) and generally comprises of shrubbery and trees.

The parking lot sheet flows in a south-easterly direction to a single catch basin that intercepts and conveys surface flows to an on-site underground storm drain which outlets onto an off-site man-made open channel that almost immediately drains into an outlet structure. Both the off-site channel and outlet structure are located adjacent to the south-easterly corner of the property. Other portions of the site also drain to the parking lot and follow the same path to the existing outlet structure. The remainder portions of the site drain towards the existing slopes along the easterly and northeasterly edge of the site. The drainage patterns as described are illustrated on the Existing Drainage Area Exhibit and the Existing Condition Hydrology Map included in the Appendix.

The existing outlet structure was originally constructed in the early 1990's as a temporary retarding basin. The original intention was that this temporary facility would be removed and storm drain facilities would be extended as a part of a proposed housing development. However, the housing development did not occur and the area adjacent to the outlet structure is now an open-space area which will not be developed.

The outlet structure is a shallow basin formed by low earthen berms with outlet pipes. A small volume of water is periodically retained within the outlet structure basin but only for short durations due to discharge through the outlet drains and the action of percolation and evaporation. There is an existing perforated pipe riser within the basin of the outlet structure that meters flows to an existing concrete "v-ditch". Only flows up to the rates of low frequency storms are delivered to the "v-ditch" because of the small diameter of the riser and limited head available to deliver flows to the ditch. The "v-ditch" carries flows in a southerly direction and also collects flows from the housing project to the south of the Church. An overflow pipe embedded in the berm of the outlet structure also provides for any potential overflow to be discharged to

grade during higher frequency storms. There are signs of limited erosion along the open space path of this flow.

The outlet structure accepts drainage from the church property and has been serving as an erosion control measure which dissipates the energy of high velocity flows resulting from the upstream on-site underground pipe that runs down a 3:1 slope.

The Church has a recorded easement that encompasses the outlet structure and has been periodically cleaning the outlet structure to minimize vegetation overgrowth and to remove refuse deposits. A copy of the recorded easement agreement is in the appendix of this report.

The temporary basin was designed to decrease peak flows coming from the property to the original flows that occurred before the construction of the main sanctuary building. These original flows were calculated in the Hydrology and Hydraulic Report for South Shores Baptist Church, prepared by David A. Boyle Engineering on January 10, 1991. The hydrology report calculated that the 100-year peak flow being discharged by the property and outletting at the south-east corner was equal to 12.33 cfs. This accounted for approximately 3.2 acres of the property's total 6.0 acres. The report also included calculations that proved the existing concrete v-ditch, which is the ultimate conveyance structure, was able to meet capacity. See Appendix for original calculations prepared by Boyle Engineering.

After the sanctuary building was constructed, the property's peak discharge increased. These peak discharge numbers have been calculated in this report and are referred to as "Existing Conditions". While the peak flows calculated for the existing conditions are larger than the original flows calculated by Boyle Engineering, the temporary basins acted as a detention basin which reduced the discharge to the existing v-ditch.

The original design of the basin included three in-line basins with outlet pipes as described above. Since the construction of the church sanctuary, 2 of the 3 basins no longer exists. While no significant signs of overflow or erosion can be seen, it is assumed that the remaining basin is undersized and will not be able to handle the needed capacity for larger storm events. For this reason, it is the intent of this report to eliminate the basin and replicate pre-existing flows as calculated by the Boyle Engineering Hydrology Report.

### *PROPOSED CONDITIONS*

In its ultimate condition the project will be developed as shown on the Proposed Master Site Plan (Architectural Plan A3.0) which is included in the Appendix. The majority of the proposed site, Area "A", is comprised of approximately 4.0 acres. To reduce peak flows, flows from Area "A" will enter a proposed underground detention system. This underground detention system will be comprised of two 84" pipes with a restrictor plate at its outlet, which temporarily holds water while slowly being released. The location of the underground detention system is shown on the Developed Condition Hydrology Map. This proposed storm drain will continue to collect flows from Area "B" downstream of the detention system before discharging to the existing concrete v-ditch at the property's south-east corner. A discharge head wall and v-ditch connection will have to be constructed to properly convey flows from Areas "A", "B", and "C" to the existing v-ditch.

The proposed underground detention basin will reduce the site's developed peak flow to match existing flows as calculated by the Boyle Engineering Hydrology report. The balance of the site that does not enter the storm drain system, shown as Area "D" is considered natural slope. These peak flows are reduced substantially, as shown in Table A-1. Area "E", comprised of driveways, sidewalk and parkway, sheet flows towards Crown Valley Parkway and is also

reduced from existing conditions. These peak flows are reduced substantially, as shown in Table A-1 below. A copy of the Developed Condition Hydrology Map that shows the concept drainage system is included in the Appendix B.

The Drainage Area Exhibits in Appendix B show the relationship between the existing and developed conditions. The amount of flows being re-directed away from the slope at the north-easterly property is significant and should be considered beneficial to the slope stability of that area. While the acreage increases for Area "A", "B", & "C" in the developed condition, the proposed on-site detention system significantly reduces the site's peak flow.

Table A-1 below shows the 2-year, 5-year, 10-year, 25-year and 100-year storm event peak flows for the existing and post development conditions. As indicated, the proposed post development peak discharge along the northerly and easterly slopes are less than the existing condition rates. Also, the proposed post development peak discharge at the south-east corner is less than the existing condition rates as calculated by the church's original hydrology report prepared by Boyle Engineering.

**TABLE A-1**

<b>HYDROLOGY SUMMARY - SOUTH-EASTERLY DISCHARGE POINT (AREAS "A", "B", &amp; "C")</b>			<b>HYDROLOGY SUMMARY - EASTERLY EXISTING SLOPE (AREA "D")</b>		
<b>FREQUENCY</b>	<b>EXISTING FLOW (CFS)</b>	<b>DEVELOPED FLOW (CFS)</b>	<b>FREQUENCY</b>	<b>EXISTING FLOW (CFS)</b>	<b>DEVELOPED FLOW (CFS)</b>
Q-2	6.0	4.6	Q-2	4.2	1.3
Q-5	8.6	6.2	Q-5	6.0	1.8
Q-10	11.0	7.6	Q-10	7.7	2.4
Q-25	13.1 / 9.6*	8.9	Q-25	11.3	2.8
Q-100	16.8 / 12.3*	10.0	Q-100	14.3	3.6

*\*Flows refer to existing peak flows as calculated by the Hydrology Report prepared by Boyle Engineering.*

<b>HYDROLOGY SUMMARY - CROWN VALLEY PARKWAY (AREA "E")</b>		
<b>FREQUENCY</b>	<b>EXISTING FLOW (CFS)</b>	<b>DEVELOPED FLOW (CFS)</b>
Q-2	0.6	0.2
Q-5	0.9	0.3
Q-10	1.2	0.35
Q-25	1.7	0.4
Q-100	2.1	0.6

## Section 6 LID, Site Design, Source Control & Treatment Control Best Management Practices (BMPs)

Minimizing a development's effects on water quality and the environment can be most effectively achieved by using a combination of BMPs which include Low Impact Development (LID) Site Design, Source Control and Treatment Control measures. These design and control measures employ a multi-level strategy. The strategy consists of: 1) reducing or eliminating post-project runoff; 2) controlling sources of pollutants; and 3) treating storm water runoff before discharging it to the storm drain system or to receiving waters.

### 6.1 Low Impact Development / Site Design BMPs

The most effective means of avoiding or reducing water quality and hydrologic impacts is through incorporation of measures into the project design. These measures should be taken into consideration early in the planning of a project as they can affect the overall design of a project.

LID BMPs are intended to collectively minimize directly connected impervious areas, limit loss of existing infiltration capacity, and protect areas that provide important water quality benefits necessary to maintain riparian and aquatic biota, and/or are particularly susceptible to erosion and sediment loss, as feasible. The design of the proposed project has incorporated site design concepts as described below.

#### Low Impact Development / Site Design BMPs

<p><b>1. Minimize the impervious footprint of the project.</b></p>	<p>The proposed project minimizes its impervious footprint through the use of minimum width designed streets, sidewalks and parking lot aisles.</p> <p>Pervious pavement cannot be utilized on this project site. Expansive soils on-site and historic geologic conditions have eliminated the use of infiltration techniques. See Section 2.4 and 2.6 of Geotechnical EIR Report in Appendix C.</p>
<p><b>2. Conserve natural areas, including existing trees, other vegetation and soils.</b></p>	<p>The project will conserve natural hillside areas along the eastern edge of the property and will preserve trees wherever possible.</p>
<p><b>3. Minimize soil compaction in landscaped areas.</b></p>	<p>Soil compaction within landscaped areas on the eastern side of the project will be reduced to a minimum by not allowing construction equipment to travel over such areas.</p>

**4. Create buffer zones for natural water bodies, where feasible and if buffer zones are not feasible, implement other buffer, such as trees, access restrictions, etc.;**

A 20' minimum buffer zone consisting of natural hill side will remain at the eastern side of the property and a 12' minimum buffer zone will remain at the southeast corner of the property.

A landscaped buffer area has been incorporated in the area between the parking lot's upper deck and Crown Valley Parkway. There are also landscape areas located between the buildings and concrete pathways. Bio-filtration swale / depressed landscape areas will be implemented during the final design.

**5. Minimize disturbances in natural drainages, for example, natural swales, topographic depressions, etc.**

See #4 above.

**6. Use of native or drought tolerant trees/shrubs:**

The project will utilize native and/or drought tolerant trees and shrubs to maximize water conservation. Existing native trees/shrubs on the eastern side of the property will be preserved to the maximum extent possible.

**7. Disconnect impervious surfaces through distributed pervious areas by draining rooftops into adjacent landscaping, using vegetated swales in lieu of underground piping, incorporating sheet flow over vegetated areas, incorporating low flow infiltration, etc.;**

Building Rooftops will be designed to drain into adjacent downspout planter boxes. The proposed Parking Structure will drain into Bio-retention / depressed landscape with elevated outlet. The existing Sanctuary building's roof drains will be disconnected and designed to drain into planter boxes. There are also landscape areas located between the buildings and concrete pathways. Bio-filtration swale / depressed landscape will be implemented during final design.

Because the soil type does not permit full infiltration, the bio-filtration swale will be lined with a non-permeable base and have a perforated pipe at the bottom to drain the filtered water.

## 6.2 Source Control BMPs

Source Control BMPs are measures focusing on reducing or eliminating post-project runoff and controlling sources of pollutants. Source Control BMPs must be included in all projects and can be represented in structural measures such as landscape, irrigation, signage considerations, materials, and design of areas; and non-structure measures such as requirements, cleaning, education, and maintenance.



**Table 6.1 Source Control Non-Structural BMPs**

Number	BMP and Objective	Included
<b><i>Routine Non-Structural BMPs (numbers correspond to those in City's WQMP)</i></b>		
N1	<p><b>Education for Property Owners, Tenants and Occupants:</b> Practical informational materials are provided to residents, occupants, or tenants to increase the public's understanding of stormwater quality, sources of pollutants, and what they can do to reduce pollutants in stormwater.</p> <p><i>Final details of non-structural source control BMPs and operation and maintenance details are not required to be included with the Preliminary WQMP, but will be required as part of the Final WQMP.</i></p>	Y
N2	<p><b>Activity Restrictions:</b> Rules or guidelines for developments are established within appropriate documents (i.e. CC&amp;Rs, lease terms, etc.) which prohibit activities that can result in discharges of pollutants.</p> <p><i>Final details of non-structural source control BMPs and operation and maintenance details are not required to be included with the Preliminary WQMP, but will be required as part of the Final WQMP.</i></p>	Y
N3	<p><b>Common Area Landscape Management:</b> Specific practices are followed and ongoing maintenance is conducted to minimize erosion and over-irrigation, conserve water, and reduce pesticide and fertilizer applications.</p> <p><i>Final details of non-structural source control BMPs and operation and maintenance details are not required to be included with the Preliminary WQMP, but will be required as part of the Final WQMP.</i></p>	Y
N4	<p><b>BMP Maintenance:</b> In order to ensure adequate and comprehensive BMP implementation, all responsible parties are identified for implementing all non-structural BMPs and for structural BMPs, cleaning, inspection, and other maintenance activities are specified including responsible parties for conducting such activities.</p> <p><i>Final details of non-structural source control BMPs and operation and maintenance details are not required to be included with the Preliminary WQMP, but will be required as part of the Final WQMP.</i></p>	Y
N5	<p><b>Title 22 CCR Compliance:</b> Hazardous waste is managed properly through compliance with applicable Title 22 regulations.</p> <p><i>Final details of non-structural source control BMPs and operation and maintenance details are not required to be included with the Preliminary WQMP, but will be required as part of the Final WQMP.</i></p>	N
N7	<p><b>Spill Contingency Plan:</b> A Spill Contingency Plan is implemented to ensure that spills are managed properly by requiring stockpiling of cleanup materials, notification of responsible agencies, disposal of cleanup materials, documentation, etc.</p> <p><i>Final details of non-structural source control BMPs and operation and maintenance details are not required to be included with the Preliminary WQMP, but will be required as part of the Final WQMP.</i></p>	N
N8	<p><b>Underground Storage Tank Compliance:</b> Because of the known or potential presence of underground storage tanks (USTs) on the project site, applicable UST regulations apply and are adhered to in order to avoid harm to humans or the environment.</p> <p><i>Final details of non-structural source control BMPs and operation and maintenance details are not required to be included with the Preliminary WQMP, but will be required as part of the Final WQMP.</i></p>	Y

Number	BMP and Objective	Included
N9	<p><b>Hazardous Materials Disclosure Compliance:</b> Because hazardous materials or wastes will be generated, handled, transported, or disposed of in association with the project, measures are taken to comply with applicable local, state, and federal regulation to avoid harm to humans and the environment.</p> <p><i>Final details of non-structural source control BMPs and operation and maintenance details are not required to be included with the Preliminary WQMP, but will be required as part of the Final WQMP.</i></p>	N
N10	<p><b>Uniform Fire Code Implementation:</b> The project includes a hazardous material storage facility or other area regulated by Article 80 and therefore implements measures to comply with this section of the Uniform Fire Code.</p> <p><i>Final details of non-structural source control BMPs and operation and maintenance details are not required to be included with the Preliminary WQMP, but will be required as part of the Final WQMP..</i></p>	Y
N11	<p><b>Common Area Litter Control:</b> Trash management and litter control procedures are specified, including responsible parties, and implemented to reduce pollution of drainage water.</p> <p><i>Final details of non-structural source control BMPs and operation and maintenance details are not required to be included with the Preliminary WQMP, but will be required as part of the Final WQMP.</i></p>	Y
N12	<p><b>Contractor/Employee Training:</b> Practical informational materials and/or training are provided to employees to increase their understanding of stormwater quality, sources of pollutants, and their responsibility for reducing pollutants in stormwater.</p> <p><i>Final details of non-structural source control BMPs and operation and maintenance details are not required to be included with the Preliminary WQMP, but will be required as part of the Final WQMP.</i></p>	Y
N13	<p><b>Housekeeping of Loading Docks:</b> Cleaning and clean up procedures are specified and implemented for loading dock areas to keep the area free for pollutants and reduce associated pollutant discharges.</p> <p><i>Final details of non-structural source control BMPs and operation and maintenance details are not required to be included with the Preliminary WQMP, but will be required as part of the Final WQMP.</i></p>	N
N14	<p><b>Drainage Facility Inspection:</b> Inspection procedures, schedules, and responsibilities are established for drainage facilities to ensure regular cleaning, inspection, and maintenance.</p> <p><i>Final details of non-structural source control BMPs and operation and maintenance details are not required to be included with the Preliminary WQMP, but will be required as part of the Final WQMP.</i></p>	Y
N15	<p><b>Street Sweeping Private Streets and Parking Lots:</b> Street sweeping frequency and responsible parties are identified and regular sweeping is conducted to reduce pollution of drainage water.</p> <p><i>Final details of non-structural source control BMPs and operation and maintenance details are not required to be included with the Preliminary WQMP, but will be required as part of the Final WQMP..</i></p>	Y
N17	<p><b>Retail Gasoline Outlets:</b> Specific operational and maintenance BMPs are implemented to the extent feasible to reduce potential for pollutant discharge from wash off by runoff, leaks, and spills.</p>	N

Number	BMP and Objective	Included
<p><i>Final details of non-structural source control BMPs and operation and maintenance details are not required to be included with the Preliminary WQMP, but will be required as part of the Final WQMP.</i></p>		
<p><b>Source Control Structural BMPs (numbers correspond to the California BMP Handbook)</b></p>		
<p><b>SD-10</b></p>	<p><b>Site Design and Landscape Planning:</b> Landscape planning methodologies are incorporated into project design to maximize water storage and infiltration opportunities and minimize surface and groundwater contamination from stormwater.</p> <p><i>Explanation/Description: Site design and landscape planning will include the implementation of trees to intercept rainfall, conservation of natural areas to the maximum extent possible, and project slopes.</i></p>	<p>Y</p>

<b>SD-11</b>	<b>Roof Runoff Controls:</b> Direct roof runoff away from paved areas and to pervious areas, cisterns, infiltration trenches, and/or storage areas for reuse to reduce total volume and rate of site runoff and retain pollutant on site.  <i>Explanation/Description: All roof drains will be disconnected to drain into planter boxes.</i>	Y
<b>SD-12</b>	<b>Efficient Irrigation:</b> Project plans include application methods to minimize irrigation water discharged into stormwater drainage systems.  <i>Explanation/Description: The project will design the timing and application methods of irrigation water to minimize the runoff of excess irrigation water into the storm drain. The project shall utilize rain shutoff devices to prevent irrigation after precipitation, drip irrigation systems, and design of irrigation systems to each landscape area's specific water requirements.</i>	Y
<b>SD-13</b>	<b>Storm Drain System Signs:</b> Stencils or affixed signs a placed adjacent to storm drain inlets to prevent waste dumping at storm drain inlets.  <i>Explanation/Description: A city approved storm drain stencil / sign will be placed on all catch basins.</i>	Y
<b>SD-20</b>	<b>Pervious Pavements:</b> Porous concrete or asphalt, blocks with pervious spaces or joints, or grass or gravel surfaces are employed to reduce runoff volume and provides treatment.  <i>Explanation/Description: Because of expansive soil types and history geologic conditions, the soils engineer does not recommend any infiltration into the sub-base to occur. See Section 2.6 of Geotechnical EIR Report in Appendix C.</i>	N
<b>SD-21</b>	<b>Alternative Building Materials:</b> Specialized building materials are employed that have lower potential to leach pollutants, and reduce need for future painting or other pollutant generating maintenance activities. For example, some treated wood contains pollutants that can leach our to the environment and some metal roofs and roofing materials result in high metal content in runoff.  <i>Explanation/Description: Alternative building materials will be considered to lower the potential to leach pollutants or reduce pollutant generating maintenance activities.</i>	Y
<b>SD-30</b>	<b>Fueling Areas:</b> Project plans are developed for cleaning, spill cleanup, containment, leak prevention, and incorporation of design to reduce rain and runoff that could come in contact with fueling areas.  <i>Explanation/Description: Project does not have fueling areas.</i>	NA
<b>SD-31</b>	<b>Maintenance Bays and Docks:</b> Project design incorporates measures to cover or otherwise eliminate run-on and off from bays and docks, and direct connections to storm drain are eliminated.  <i>Explanation/Description: Project does not have maintenance bays or docks.</i>	NA

<p><b>SD-32</b></p>	<p><b>Trash Enclosures:</b> Trash storage areas are covered and enclosed to prevent introduction of trash and debris to site runoff.</p> <p><i>Explanation/Description: The trash container area will contain trash bins with covers and the areas will be roofed over to prevent rain from entering the bin, reducing water pollution. The design of the trash container area includes features to prevent drainage from adjoining roofs and pavement from entering the trash container areas. The trash enclosure drain(s) will be connected to the sewer.</i></p> <p><i>The trash container area will be surrounded by walls and gates to prevent off-site transport of trash.</i></p> <p><i>The bins will be inspected on a regular basis as needed for the amount of trash generated.</i></p> <p><i>The South Shores Church maintenance personnel and waste removal company will be instructed to make sure that covers are kept closed and only opened at the time the trash is deposited.</i></p>	<p>Y</p>
<p><b>SD-33</b></p>	<p><b>Vehicle and Equipment Washing Areas:</b> Designated wash areas or facilities are contained and wash water is reused, treated, or otherwise properly disposed of.</p> <p><i>Explanation/Description: Project does not have vehicle and equipment washing areas.</i></p>	<p>NA</p>
<p><b>SD-34</b></p>	<p><b>Outdoor Material Storage Areas:</b> Outdoor storage areas for materials containing pollutants, especially hazardous materials, are covered and enclosed, on impervious surfaces, and include secondary containment when applicable.</p> <p><i>Explanation/Description: Project does not have outdoor material storage areas.</i></p>	<p>NA</p>
<p><b>SD-35</b></p>	<p><b>Outdoor Work Areas:</b> Outdoor work areas are covered, contained, and treated as necessary to reduce opportunity of pollutants from work activities to enter stormwater.</p> <p><i>Explanation/Description: Project does not have outdoor work areas.</i></p>	<p>NA</p>
<p><b>SD-36</b></p>	<p><b>Outdoor Processing Areas:</b> Outdoor processing areas are covered, contained, and treated as necessary to reduce opportunity of pollutants from work activities to enter stormwater.</p> <p><i>Explanation/Description: Project does not have outdoor processing areas.</i></p>	<p>NA</p>

**See below from 2011-05-19 Model WQMP TGD - Preparation and Approval criteria:****7.II-5.1 Conceptual or Preliminary WQMP Preparation**

To facilitate early WQ planning and ensure that WQ protection and LID principles are considered in the earliest phases of a project, a the local jurisdiction will suggest that the project proponent prepare a Conceptual or Preliminary WQMP prior to a complete or final Project WQMP for full review and approval. A Conceptual or Preliminary WQMP may be used by the local jurisdiction during the land use entitlement process or as part of a project application for discretionary project approval.

A Conceptual or Preliminary WQMP supports the CEQA process and provides documentation to support a checklist for an Initial Study and Negative Declaration or Mitigated Negative Declaration, or serves as the basis for the water quality section of an EIR. It should also serving as the basis for the Lead Agency and Responsible Agency to conclude that the MEP standard is being met, by serving as the basis that selected BMPs will not have the potential to cause significant effects and/or that the effects have been mitigated, and "are not significant with mitigation". The Conceptual or Preliminary WQMP should to be circulated with the CEQA document or summarized within the circulated CEQA document.

A WQMP Template has been produced to assist project proponents with developing a Conceptual or Preliminary WQMP (available at [www.ocwatersheds.com](http://www.ocwatersheds.com)). The level of detail in a Conceptual or Preliminary WQMP can vary somewhat upon the level of detail known at the time discretionary project approval is sought, but must contain at a minimum the following information:

- Local project identifier and description (application number, tentative tract number, review number, etc.)
- Site plan (tentative map, major project features, use exhibit, etc.) showing the following
  - Property or project boundaries
  - Locations of buildings, landscaping, streets, curb and gutter, storm drainage system, and other major project features
  - Direction of surface drainage
  - Existing easements
  - Surface waters
  - Areas of known or potential hazards such as landfills, soil and groundwater contamination, Alquist-Priolo fault zones, etc.
  - Other project features or activities that may generate pollutants such as wash racks, trash enclosures, fuelling areas, loading docks, etc.

- Preliminary site assessment information
  - Most proximate and downstream receiving waters and any impairments
  - POCs and primary POCs, and the related conclusions that are to be made from this information
  - Identification of any hydrologic conditions of concern and the supporting rationale
- LID feasibility analysis
- Proposed LID BMP selection rationale and supporting details and calculations (or sub-regional/regional LID BMPs if applicable)
- Proposed hydromodification control BMPs and calculations
- Proposed treatment control BMPs and calculations
- Any proposed project specific credits or alternative compliance methods planned
- Preliminary Source Control BMP information
- Proposed parties responsible for the long-term operation and maintenance of proposed BMPs
- Proposed funding mechanisms for the long-term operation and maintenance of the proposed BMPs
- The list of standard WQMP requirements as indicated earlier, including access easement, records to be kept, records retention, inspection frequencies, etc.

Local jurisdiction staff will review and evaluate the Conceptual / Preliminary Project WQMP for general acceptance and conceptual or preliminary approval, and will offer guidance toward plan elements necessary for approval of the full Project WQMP. Additional information and submittals may be necessary for conceptual or preliminary approval. It is the responsibility of the project proponent to provide the additional information for consideration by the local jurisdiction.

## Water Quality Grease Control Requirements for Food Service Establishments (FSEs) - N/A

### Waste Cooking Oil /Yellow Grease/Tallow Management - N/A

FSEs with food preparation or cooking practices that generate grease or oil as part of their operation shall install a self-contained oil retention unit. No storage of grease barrels/dumpsters shall be allowed outdoors.

### Equipment/Mat Washing Areas: N/A

FSE must dedicate a specific area for the washing of floor mats and other equipment. Options include:

- A properly-sized indoor mop or utility sink connected to the grease interceptor.
- A contained outdoor wash-down area connected to the grease interceptor that must be protected from rain water runoff.
- Adequate signage shall be provided to designate washing area and state the prohibition of discharging washwater to the storm drain system.
- Employees must be regularly trained to utilize designated areas for washing.

**NOTE: Washwater draining to parking lots, streets and storm drains is prohibited.**

### Roof Top Grease Control N/A

FSE shall install and maintain a grease diaper (hydrophobic absorbent pad) around any/all new or existing rooftop grease exhaust fan(s).

Resources for grease diapers include, but are not limited to:

- [www.greasecontrol.com](http://www.greasecontrol.com)
- [www.facilitec-sw.com](http://www.facilitec-sw.com)

## 6.3 Treatment Control BMPs

Treatment control BMPs utilize treatment mechanisms to remove pollutants that have entered stormwater runoff.

The following table identifies the treatment control BMPs included in the proposed project.

<p><b>LID BMP</b> – a BMP that provides retention or biotreatment as part of an LID strategy – these may include hydrologic source controls (HSCs), retention, and biotreatment BMPs</p>
--



LID BMPs by Category

Infiltration	Evapo-transpiration and Evaporation	Harvest and Use	Biotreatment
<ul style="list-style-type: none"> <li>➤ Infiltration Trenches</li> <li>➤ Infiltration Basins</li> <li>➤ Bioretention Without Underdrains</li> <li>➤ Drywells</li> <li>➤ Permeable Pavement</li> <li>➤ Proprietary Infiltration</li> </ul>	<ul style="list-style-type: none"> <li>➤ Green Roofs</li> <li>➤ Brown Roofs</li> <li>➤ Blue Roofs</li> </ul>	<ul style="list-style-type: none"> <li>➤ Cisterns</li> <li>➤ Underground Detention</li> <li>➤ Irrigation Use</li> <li>➤ Domestic Use</li> </ul>	<ul style="list-style-type: none"> <li>➤ Bioretention With Underdrains</li> <li>➤ Stormwater Planter Boxes With Underdrains</li> <li>➤ Constructed Wetlands</li> <li>➤ Vegetated Swales</li> <li>➤ Vegetated Filter Strips</li> <li>➤ Dry Extended Detention Basins</li> <li>➤ Wet Extended Detention Basins</li> <li>➤ Proprietary Detention</li> </ul>

Environmental Benefits of BMPs.

BMP	Runoff Quality Enhancement	Water Conservation (Recharge/Reuse)	Heat Island Reduction	Energy Conservation	Air Pollution Reduction	Habitat
Bioretention	✓	✓	✓		✓	✓
Permeable Pavement	✓	✓				
Capture/Reuse	✓	✓				
Vegetated Roofs	✓		✓	✓	✓	✓
Soil Amendments	✓	✓				✓
Downspout Disconnection		✓				
Filter Strips	✓	✓	✓			
Vegetated Swales	✓	✓	✓		✓	
Infiltration (Retention) Basins	✓	✓				
Infiltration Trenches	✓	✓				
Dry Wells	✓	✓				
Dry Ponds (Detention Basins)	✓					
Constructed Wetlands	✓		✓		✓	✓
Wet Ponds	✓					✓
Media Filters/Filter Basins	✓					
Proprietary Devices	✓					

Source: Adapted from WERF, 2006.

BMP Site Suitability Criteria.

BMP	Soil HSG				Depth to groundwater		Depth to impermeable layer/bedrock		Slope			High Landslide Risk	Soil Contamination
	A	B	C	D	< 10'	> 10'	< 5'	> 5'	0-5%	5-15%	> 15%		
Bioretention	✓	✓				✓		✓	✓	✓ if terraced			
Bioretention with underdrain			✓	✓	✓	✓	✓	✓	✓	✓ if terraced		✓	✓ with liner
Permeable Pavement	✓	✓				✓		✓	✓				
Permeable Pavement with underdrain			✓	✓	✓	✓	✓	✓	✓			✓	✓ with liner
Capture/Reuse	✓	✓	✓	✓	✓	✓	✓	✓	✓	✓	✓	✓	✓
Vegetated Roofs	✓	✓	✓	✓	✓	✓	✓	✓	✓	✓	✓	✓	✓
Soil Amendments	✓	✓	✓	✓	✓	✓	✓	✓	✓	✓	✓		
Downspout Disconnection	✓	✓	✓	✓	✓	✓	✓	✓	✓	✓			
Filter Strips	✓	✓	✓	✓		✓		✓	✓				
Vegetated Swales	✓	✓	✓	✓		✓		✓	✓	✓			
Infiltration (Retention) Basins	✓	✓	✓			✓		✓	✓				
Infiltration trenches	✓	✓	✓			✓		✓	✓				
Dry wells	✓	✓	✓			✓		✓	✓				
Dry ponds (detention basins)	✓	✓	✓			✓		✓	✓				✓ with liner
Constructed Wetlands		✓	✓	✓	✓	✓	✓	✓	✓				✓ with liner
Wet ponds		✓	✓	✓	✓	✓	✓	✓	✓	✓			✓ with liner
Media filters / Filter Basins	✓	✓	✓	✓	✓	✓	✓	✓	✓	✓	✓	✓	✓
Proprietary Devices	✓	✓	✓	✓	✓	✓	✓	✓	✓	✓	✓	✓	✓

Source: The Low Impact Development Center, Inc.

Table 6.2 Treatment Control BMPs

Number	BMP and Objective
TC-30	<b>Vegetated Swale:</b> Open, shallow, vegetated channels that collect and slowly convey runoff through the property. Filters runoff through vegetation, subsoil matrix, and/or underlying soils; traps pollutants, promotes infiltration and reduce flow velocity.
TC-32	<b>Bioretention:</b> A soil and plant based filtration strategy that involved capturing stormwater in depressed landscaped areas. Bioretention practices are flexible strategies for using landscaping as treatment.
MP-40	<b>Media Filter (proprietary):</b> Similar to constructed media filter but manufactured as self-contained filtering vaults, units, or cartridges.
MP-51	<b>Vortex Separator:</b> Similar to wet vaults but round and use centrifugal action as primary separation mechanism.
TC-60	<b>Multiple Systems:</b> A system that uses two or more BMPs in series to increase treatment. Useful when one BMP does not provide sufficient treatment alone.

### 6.3.1 SELECTION

The BMPs for this project were selected and sized based on the most current Orange County Model Water Quality Management Plan (WQMP) and the accompanying Technical Guidance Document (TGD) and South Orange County Interim Hydromodification Requirements and Hydromodification Management Plan (HMP).

The project design met the appropriate performance criteria for LID implementation predominantly through biotreatment/biofiltration to the MEP, as the LID retention feasibility analysis was conducted and it was determined that retention is not feasible on this site (See Section 6.3.4) therefore a myriad of bioretention/biotreatment BMPs were designed and work in conjunction with a comprehensive BMP treatment train approach which also includes subsequent hydrodynamic separation and detention.

The developed condition of the project site consists of four drainage patterns. The majority of the proposed site, Area "A", will drain to an underground storm drain system. Area "A"s water quality will be improved through the use of Bioretention with Underdrains (BIO-1), such as roof drain planter boxes (BMP-1), Vegetated Swales (BIO-2), such as bioswales (BMP-2), and Proprietary Biotreatment (BIO-7), such as Filterra Systems (BMP-3). To reduce peak flows, flows from Area "A" will enter an on-site detention system, consisting of a pretreatment Hydrodynamic Separation Device (PRE-1), such as a CDS Unit (BMP-4) and underground detention system. The underground detention system will consist of a steel-reinforced polyethylene pipe network, which will control peak discharge flows with a restrictor plate. Reduction of the site's peak discharge is not only necessary due to the increase of impervious area, but also because of the elimination of the off-site existing drainage basin. After flows leave the on-site detention system, the proposed storm drain pipe will discharge directly into the existing concrete v-ditch, bypassing the existing drainage basin.

Area "B" will enter the proposed storm drain pipe downstream of the on-site detention system before discharging into the existing concrete v-ditch. Area "B"s water quality will be improved through the use of Bioretention with Underdrains (BIO-1), such as roof drain planter boxes (BMP-1), and Proprietary Biotreatment (BIO-7), such as Filterra Units (BMP-3).

While the project is to be constructed in phases, the majority of the storm drain infrastructure will be constructed in Phase 1. This includes the underground detention basin and CDS Unit and the RCP Storm Drain connection to the existing concrete v-ditch at the south-easterly corner. During each phase of construction, appropriate BMPs will be constructed to treat newly constructed buildings and/or hardscape, such as the parking deck, streets, and walkways. See Section 4 for which BMPs will be constructed at each phase or refer to the Construction Phasing Exhibits prepared by Matlock and Associates located in Section 7 of this report.

To comply with the project's EIR, an alternate design has been considered for the project in which footprints of proposed buildings have decreased. In this case, the alternate plan will incorporate the same BMP concept as the proposed version. The alternate will differ by decreasing impervious area, thus improving water quality.

#### **6.3.4 RESTRICTIONS ON USE OF INFILTRATION BMPS**

The proposed project does not include infiltration BMPS. See Table 2.7: Infiltration BMP Feasibility Worksheet and Worksheet I: Summary of Groundwater-related Feasibility Criteria below.

**BIORETENTION WITH UNDERDRAINS (HSC-2) – Impervious Area Dispersion**

Hydrologic Source Control, HSC-2, is used in Area A-5 to reduce the design capture storm depth. HSC-2 is used in are B-1 as a self-treating area.

Areas (See WQMP Exhibit):

	<b>AREA (ac)</b>	<b>BMP DESCRIPTION</b>	<b>Effect of HSC</b>	<b>Percent Capture Provided by HSC</b>
A-5	0.5	HSC-2, Impervious Area Dispersion	0.15"	28.5%
B-1	0.3	HSC-2, Impervious Area Dispersion	1.0"	80% (Self-treating area)

**SEE SIZING CALCULATIONS IN SECTION 6.3.2**

**HSC-2: Impervious Area Dispersion**

Impervious area dispersion refers to the practice of routing runoff from impervious areas, such as rooftops, walkways, and patios onto the surface of adjacent pervious areas. Runoff is dispersed uniformly via splash block or dispersion trench and soaks into the ground as it move slowly across the surface of pervious areas. Minor ponding may occur, but it is not the intent of this practice to actively promote localized on-lot storage (See HSC-1: Localized On-Lot Infiltration).

**Feasibility Screening Considerations**

- Impervious area dispersion can be used where infiltration would otherwise be infeasible, however dispersion depth over landscaped areas should be limited by site-specific conditions to prevent standing water or geotechnical issues.

**Opportunity Criteria**

- Rooftops and other low traffic impervious surface present in drainage area.
- Soils are adequate for infiltration. If not, soils can be amended to improve capacity to absorb dispersed water (see MISC-2: Amended Soils).
- Significant pervious area present in drainage area with shallow slope
- Overflow from pervious area can be safely managed.

**OC-Specific Design Criteria and Considerations**

- Soils should be preserved from their natural condition or restored via soil amendments to meet minimum criteria described in Section .
- A minimum of 1 part pervious area capable of receiving flow should be provided for every 2 parts of impervious area disconnected.
- The pervious area receiving flow should have a slope  $\leq 2$  percent and path lengths of  $\geq 20$  feet per 1000 sf of impervious area.
- Dispersion areas should be maintained to remove trash and debris, loose vegetation, and protect any areas of bare soil from erosion.
- Velocity of dispersed flow should not be greater than 0.5 ft per second to avoid scour.

*Also known as:*

- Downspout disconnection
- Impervious area disconnection
- Sheet flow dispersion



Simple Downspout Dispersion  
Source:  
[toronto.ca/environment/water.htm](http://toronto.ca/environment/water.htm)

**BIORETENTION WITH UNDERDRAINS (BIO-1) – Downspout Planter Box / Storm Water Planters - BMP-1:**

Areas (See WQMP Exhibit):

	<b>AREA (ac)</b>	<b>BMP DESCRIPTION</b>	<b>SIZING METHODOLOGY</b>	<b>DESIGN CAPTURE VOLUME, DCV REQUIRED</b>	<b>DESIGN CAPTURE VOLUME, DCV PROVIDED</b>
A-1	0.49	Downspout Planter Box	Capture Efficiency Method for Volume-Based, Constant Drawdown BMPs, Worksheet C	512 cu-ft	588 cu-ft
A-6	0.99	Storm Water Planter in treatment train with Filterra catch basin	Capture Efficiency of Volume Based, Constant Drawdown BMP based on Design Volume; Worksheet E	740 cu-ft ±	300 cu-ft, 45% Capture Efficiency (Remainder to be treated w/ BIO-7)
B-2	0.17	Storm Water Planter	Capture Efficiency Method for Volume-Based, Constant Drawdown BMPs, Worksheet C	142 cu-ft	340 cu-ft
B-3	0.17	Storm Water Planter	Capture Efficiency Method for Volume-Based, Constant Drawdown BMPs, Worksheet C	142 cu-ft	288 cu-ft
B-4	0.10	Storm Water Planter	Capture Efficiency Method for Volume-Based, Constant Drawdown BMPs, Worksheet C	69 cu-ft	228 cu-ft

**SEE SIZING CALCULATIONS IN SECTION 6.3.2**

**BIO-1: Bioretention with Underdrains**

Bioretention stormwater treatment facilities are landscaped shallow depressions that capture and filter stormwater runoff. These facilities function as a soil and plant-based filtration device that removes pollutants through a variety of physical, biological, and chemical treatment processes. The facilities normally consist of a ponding area, mulch layer, planting soils, and plants. As stormwater passes down through the planting soil, pollutants are filtered, adsorbed, biodegraded, and sequestered by the soil and plants. Bioretention with an underdrain are utilized for areas with low permeability native soils or steep slopes where the underdrain system that routes the treated runoff to the storm drain system rather than depending entirely on infiltration. **Bioretention must be designed without an underdrain** in areas of high soil permeability.

*Also known as:*

- Rain gardens with underdrains
- Vegetated media filter
- Downspout planter boxes



Bioretention  
Source: Geosyntec Consultants

### *OC-Specific Design Criteria and Considerations*

- Ponding depth should not exceed 18 inches; fencing may be required if ponding depth is greater than 6 inches to mitigate drowning.
- The minimum soil depth is 2 feet (3 feet is preferred).
- The maximum drawdown time of the bioretention ponding area is 48 hours. The maximum drawdown time of the planting media and gravel drainage layer is 96 hours, if applicable.
- Infiltration pathways may need to be restricted due to the close proximity of roads, foundations, or other infrastructure. A geomembrane liner, or other equivalent water proofing, may be placed along the vertical walls to reduce lateral flows. This liner should have a minimum thickness of 30 mils.
- If infiltration in bioretention location is hazardous due to groundwater or geotechnical concerns, a geomembrane liner must be installed at the base of the bioretention facility. This liner should have a minimum thickness of 30 mils.
- The planting media placed in the cell shall be designed per the recommendations contained in MISC-1: Planting/Storage Media
- Plant materials should be tolerant of summer drought, ponding fluctuations, and saturated soil conditions for 48 hours; native place species and/or hardy cultivars that are not invasive and do not require chemical inputs should be used to the maximum extent feasible
- The bioretention area should be covered with 2-4 inches (average 3 inches) or mulch at the start and an additional placement of 1-2 inches of mulch should be added annually.
- Underdrain should be sized with a 6 inch minimum diameter and have a 0.5% minimum slope.
- Underdrain should be slotted polyvinyl chloride (PVC) pipe; underdrain pipe should be more than 5 feet from tree locations (if space allows).
- A gravel blanket or bedding is required for the underdrain pipe(s). At least 0.5 feet of washed aggregate must be placed below, to the top, and to the sides of the underdrain pipe(s).
- An overflow device is required at the top of the bioretention area ponding depth.
- Dispersed flow or energy dissipation (i.e. splash rocks) for piped inlets should be provided at basin inlet to prevent erosion.
- Ponding area side slopes shall be no steeper than 3:1 (H:V) unless designed as a planter box BMP with appropriate consideration for trip and fall hazards.



***Downspout Planter Box***



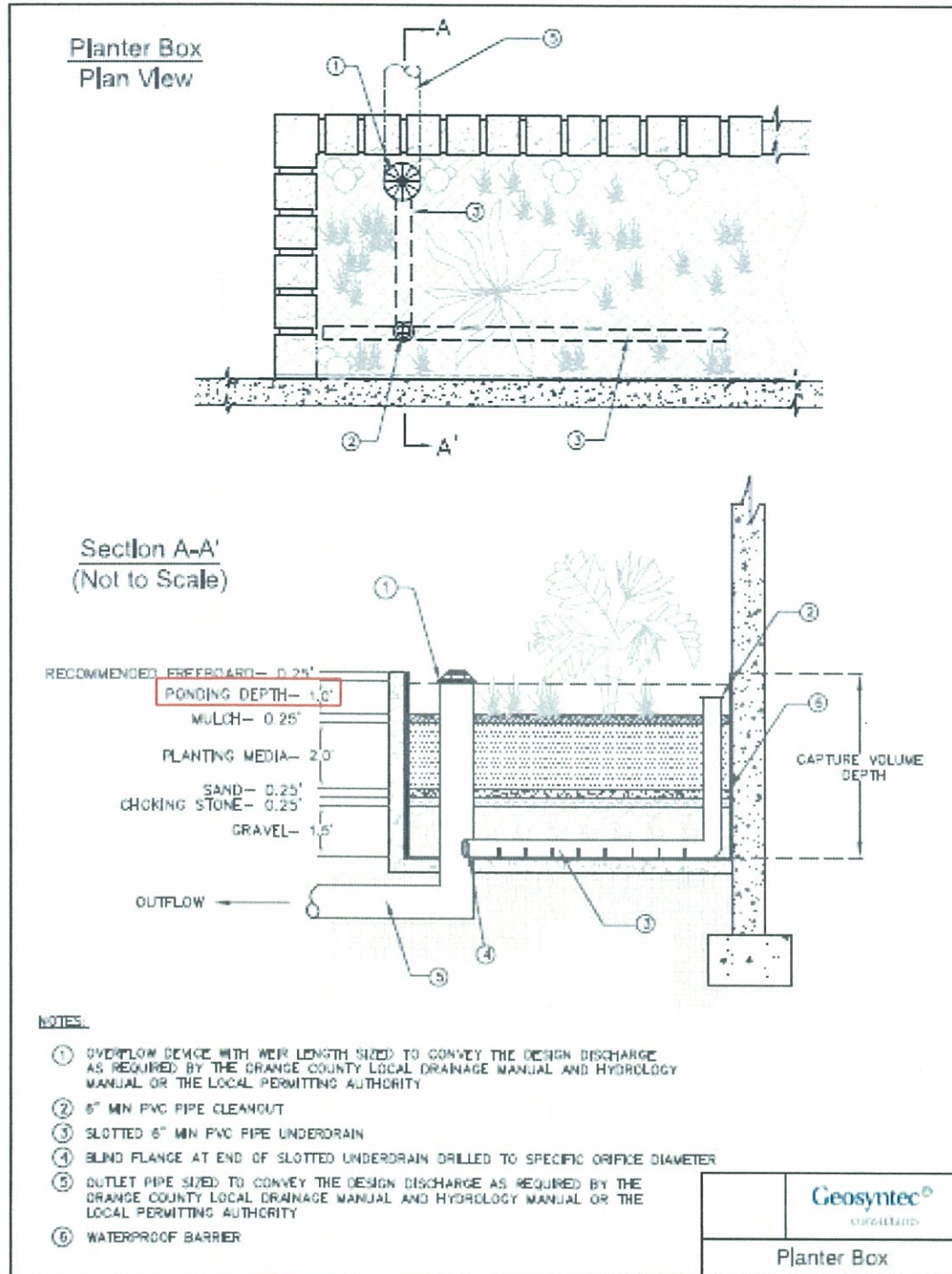

**Downspout Planter Box Detail**



*Storm Water Planters*

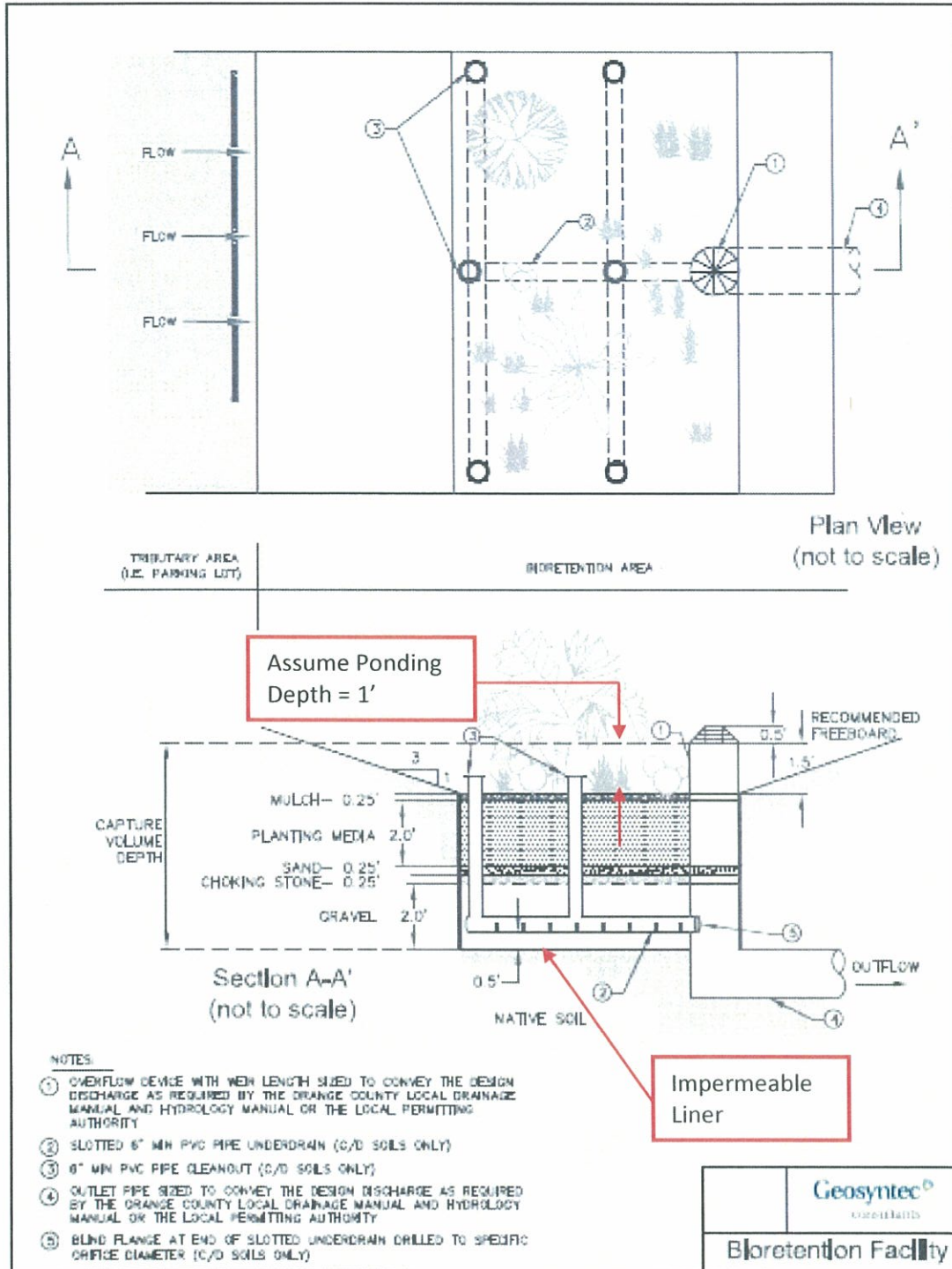

**Storm Water Planter Detail**

**VEGETATED SWALE (BIO-2): Bioswale – BMP-2:**

Areas (See WQMP Exhibit):

	<b>AREA (ac)</b>	<b>BMP DESCRIPTIO N</b>	<b>SIZING METHODOLOGY</b>	<b>DESIGN FLOWRATE, Q<sub>design</sub> REQUIRED</b>	<b>LENGTH OF SWALE REQUIRED</b>	<b>LENGTH OF SWALE PROVIDED</b>
A-5	0.50	Biofiltration Swale, Bottom Width, b=3.0'	Capture Efficiency Method for Flow-Based BMPs, Worksheet D	0.0825 cfs	153.6 FT	155 FT

**SEE SIZING CALCULATIONS IN SECTION 6.3.2**

BIO-2: Vegetated Swale

Vegetated swale filters (vegetated swales) are open, shallow channels with low-lying vegetation covering the side slopes and bottom that collect and slowly convey runoff flow to downstream discharge points. Vegetated swales provide pollutant removal through settling and filtration in the vegetation (usually grasses) lining the channels. In addition, they provide the opportunity for volume reduction through infiltration and ET, and reduce the flow velocity in addition to conveying storm water runoff. Where soil conditions allow, volume reduction in vegetated swales can be enhanced by adding a gravel drainage layer underneath the swale allowing additional flows to be retained and infiltrated. Where slopes are shallow and soil conditions limit or prohibit infiltration, an underdrain system or low flow channel for dry weather flows may be required to minimize ponding and convey treated and/or dry weather flows to an acceptable discharge point. An effective vegetated swale achieves uniform sheet flow through a densely vegetated area for a period of several minutes. The vegetation in the swale can vary depending on its location within the project area and is generally the choice of the designer, subject to the design criteria outlined in this section.



**OC-Specific Design Criteria and Considerations**

- Swales should have a minimum bottom width of 2 feet and a maximum bottom width of 10 feet. Swale dividers should be used if the bottom width must exceed 10 feet to promote even distribution of flow across the swale. Local jurisdictions may require larger minimum widths based on maintenance requirements.
- The channel side slope should not exceed 2:1 (H:V) for a total swale depth of 1 foot or less. For deeper swales or mowed grass swales, the maximum channel side slope should be 3:1. Where space is constrained, swales may have vertical concrete or block walls provided that slope

stability, maintenance access and public safety considerations are met.

- The minimum swale length for biotreatment applications is 100 feet. The minimum residence time for flows in the swale is 10 minutes.
- If slope is less than 1.5%, underdrains should be provided for the length of the swale
- A gravel blanket or bedding is required around the underdrain pipe(s). At least 0.5 feet of washed aggregate must be placed below, to the top, and to the sides of the underdrain pipe(s).
- If an underdrain is included, an amended soil layer of 1 foot minimum thickness must be provided above the underdrain meeting the specifications of MISC-1: Planting/Storage Media.
- The maximum bed slope in flow direction should not exceed 6% (unless check dams are provided).
- The maximum flow velocity should not exceed 1.0 ft/sec for water quality treatment swales.
- For infrequently mowed swales, a maximum flow depth of 4 inches should be implemented. For frequently mowed turf swales, the maximum flow depth is 2 inches.
- The vegetation height should be maintained between 4 to 6 inches.
- Gradual meandering bends in the swale are desirable for aesthetic purposes and to promote slower flow and particulate settling.
- Blockages in the swale that result in uneven flow distribution and points of concentrated flow should be avoided. Blockages that should be avoided include trees, bushes, light pole piers, and utility vaults or pads.

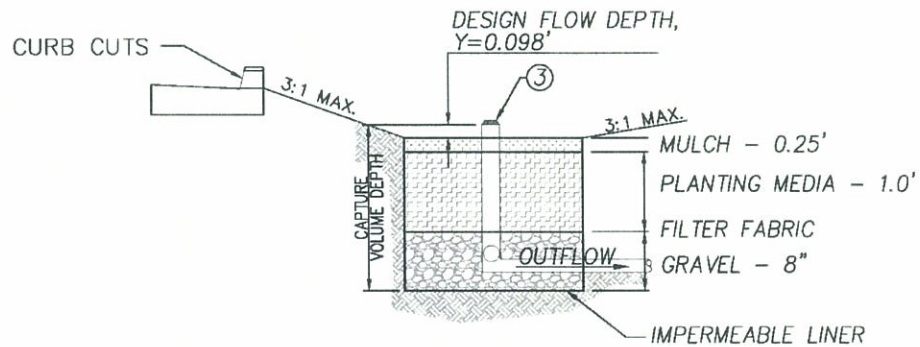
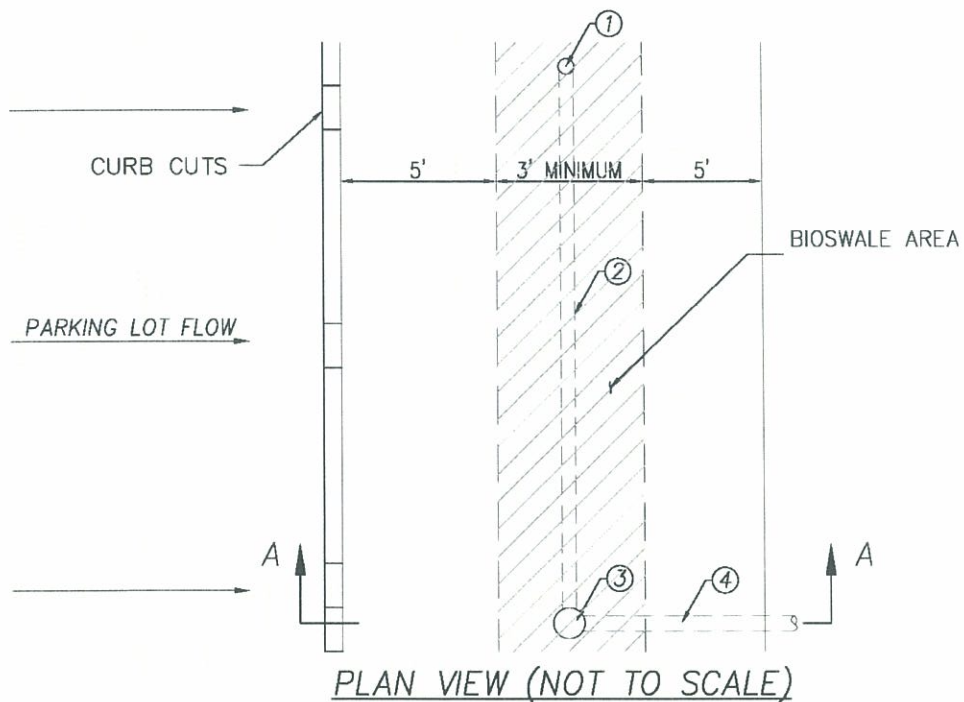

**NOTES**

- ① 4" MIN. PVC CLEAN OUT
- ② 4" MIN. PERFORATED PVC PIPE
- ③ OVERFLOW DEVICE WITH WEIR LENGTH SIZED TO CONVEY THE DESIGN DISCHARGE AS REQUIRED BY THE ORANGE COUNTY LOCAL DRAINAGE MANUAL AND HYDROLOGY MANUAL
- ④ OUTLET PIPE SIZED TO CONVEY THE DESIGN DISCHARGE AS REQUIRED BY THE ORANGE COUNTY LOCAL DRAINAGE MANUAL AND HYDROLOGY MANUAL

**BIOSWALE DETAIL**

**PROPRIETARY BIO-FILTRATION (BIO-7) - Filterra Systems - BMP-3:**

Areas (See WQMP Exhibit):

	<b>AREA (ac)</b>	<b>BMP DESCRIPTION</b>	<b>SIZING METHODOLOGY</b>	<b>DESIGN FLOWRATE, <math>Q_{design}</math> REQUIRED</b>	<b>FLOWRATE PROVIDED</b>
A-2	0.26	Filterra Roofdrain System (4'x6')	Capture Efficiency Method for Flow-Based BMPs; Worksheet D	0.056 cfs	0.061 cfs
A-3	0.26	Filterra Roofdrain System (4'x6')	Capture Efficiency Method for Flow-Based BMPs; Worksheet D	0.056 cfs	0.061 cfs
A-4	0.60	Filterra Catch Basin (6'x10')	Capture Efficiency Method for Flow-Based BMPs; Worksheet D	0.124 cfs	0.140 cfs
A-6	0.99	Filterra Catch Basin (6'x10')	Capture Efficiency Method for Flow-Based BMPs; Worksheet D	0.140 cfs	0.140 cfs
A-7	0.56	Filterra Catch Basin (Two-4'x6')	Capture Efficiency Method for Flow-Based BMPs; Worksheet D	0.116 cfs	0.122 cfs
A-8	0.23	Filterra Roofdrain System (4'x6')	Capture Efficiency Method for Flow-Based BMPs; Worksheet D	0.049 cfs	0.061 cfs
B-5	0.18	Filterra System (4'x4')	Capture Efficiency Method for Flow-Based BMPs; Worksheet D	0.037 cfs	0.037 cfs

**SEE SIZING CALCULATIONS IN SECTION 6.3.2**



## Filtterra® Overview Stormwater Bioretention Filtration System



Save valuable space with small footprint for urban sites

Improve BMP aesthetics with attractive trees or shrubs

Reduce lifetime cost with safer and less expensive maintenance

### Remove Pollutants and Comply with NPDES

Filtterra® is well-suited for the ultra-urban environment with high removal efficiencies for many pollutants such as petroleum, heavy metals, phosphorus, nitrogen, TSS and bacteria. Filtterra® is similar in concept to bioretention in its function and applications, with the major distinction that Filtterra® has been optimized for high volume/flow treatment and high pollutant removal. It takes up little space (often only a 4'x4' unit for each mandatory catch basin) and may be used on highly developed sites such as landscaped areas, green space, parking lots and streetscapes. Filtterra® is exceedingly adaptable and is the urban solution for Low Impact Development.

Stormwater flows through a specially designed filter media mixture contained in a landscaped concrete container. The filter media captures and immobilizes pollutants; those pollutants are then decomposed, volatilized and incorporated into the biomass of the Filtterra® system's micro/macro fauna and flora. Stormwater runoff flows through the media and into an underdrain system at the bottom of the container, where the treated water is discharged. Higher flows bypass the Filtterra® via a downstream inlet structure, curb cut or other appropriate relief.

### Expected Average Pollutant Removal Rates (Ranges Varying with Particle Size, Pollutant Loading and Site Conditions)

<b>TSS Removal</b>	85%
<b>Phosphorous Removal</b>	60% - 70%
<b>Nitrogen Removal</b>	43%
<b>Total Copper Removal</b>	> 58%
<b>Dissolved Copper Removal</b>	46%
<b>Total Zinc Removal</b>	> 66%
<b>Dissolved Zinc Removal</b>	58%
<b>Oil &amp; Grease</b>	> 93%





### Filterra® Piping Technical Details

Filterra® is supplied with an internal underdrain system that exits a wall in a perpendicular direction. Most efficient drainage is accomplished when the drain exits on the lower side of the Filterra®, i.e. nearest the overflow bypass. This is more important when using the larger sized Filterra® Systems.

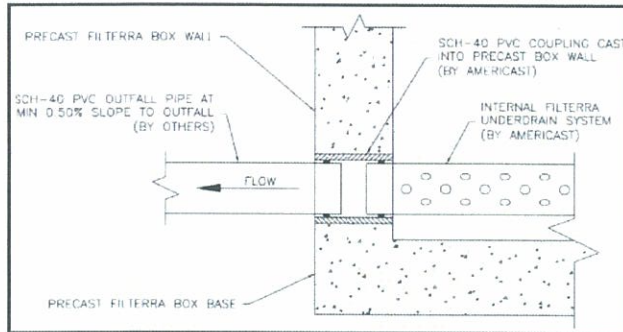

*Drawing DP1:  
Section View through Filterra Precast  
Box Wall at Outfall Pipe Connection*

All units are supplied with the drainage pipe coupling precast into the wall, at a depth of 3.50 feet (INV to TC). Drawing DP1 is a detail of the coupling. The coupling used is SCH-40 PVC.

Typically, a minimum slope of 0.5% is adequate to accommodate the flow of treated water from the Filterra®, but each site may present unique conditions based on routing of the outfall pipe (elbows). The pipe must not be a restricting point for the successful operation of Filterra®. All connecting pipes must accommodate freefall flow. Table 3 lists WA DOE approved treatment sizing flow rates of the various size Filterra® units. A safety factor of at least two should be used to size piping from the Filterra based on these conservative approved treatment flow rates.

Table 3: Filterra Flow Rates & Pipe Details

Important Note: Actual flow rate may be more than double rates below.

Filterra® Size (feet)	Expected Flow Rate (cubic feet/second)	Connecting Drainage Pipe
4x4	0.037	4" SCH-40 PVC
4 x 6 or 6 x 4	0.061	4" SCH-40 PVC
4x6.5 or 6.5x4	0.061	4" SCH-40 PVC
4 x 8 or 8 x 4	0.075	4" SCH-40 PVC
4x16 or 16x4	0.150	6" SCH-40 PVC
6 x 6	0.084	4" SCH-40 PVC
6 x 8 or 8 x 6	0.112	4" SCH-40 PVC
6 x 10 or 10 x 6	0.140	6" SCH-40 PVC
6 x 12 or 12 x 6	0.168	6" SCH-40 PVC
8x12 or 12x8	0.224	6" SCH-40 PVC
8x16 or 16x8	0.229	6" SCH-40 PVC
8x18 or 18x8	0.337	6" SCH-40 PVC
8x20 or 20x8	0.374	6" SCH-40 PVC

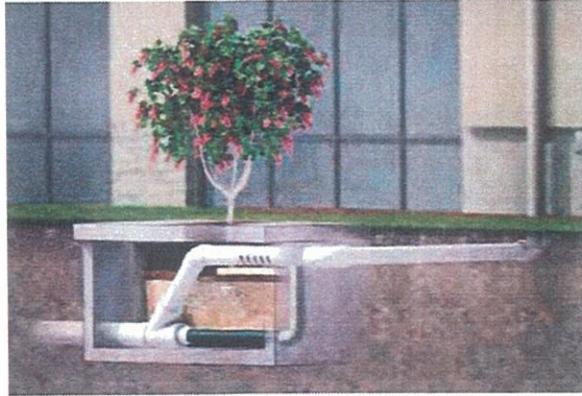

## NEW FILTERRA MODEL

CONTACT US FOR DETAILS



Filtterra® Roofdrain Stormwater Treatment System  
A Greenroof at Ground Level™

### Filtterra® Roofdrain System

The Filtterra Roofdrain System treats piped in stormwater runoff from rooftops. Using bioretention filtration the system captures and immobilizes pollutants of concern such as; TSS, nutrients and metals.

Stormwater continues to flow through the media and into the underdrain system, where treated water is discharged. Higher flows bypass the bioretention treatment via an overflow/bypass pipe design.

### Features and Benefits

#### Best Value for Rooftop Treatment.

- compact size
- needs no external bypass
- easy installation
- simple maintenance

#### Versatile.

Filtterra Roofdrain can be used for:

- new construction
- retrofits
- commercial or residential applications.

Filtterra Roofdrain can be placed:

- At grade
- Slightly above grade to meet elevation challenges of high water tables
- Install next to or away from your building

**Maintenance.** Maintenance is simple and safe (at ground level), and the first year is provided FREE with the purchase of every unit. The procedure is so easy you can perform it yourself.

**Protection.** The Filtterra Roofdrain's hydraulic configuration was tested by the Colorado State University Hydraulics Laboratory.

Below grade treatment using Filtterra roofdrain avoids the slipping hazard liabilities of daylighted roofdrains during freezing weather.

Protect from erosion with Filtterra's monolithic water tight design.

### Expected Pollutant Removal

(Ranges Varying with Particle Size, Pollutant Loading and Site Conditions)

TSS Removal	85%
Phosphorus Removal	60% - 70%
Zinc Removal	> 66%
Copper Removal	>58%
Nitrogen Removal	43%
TPH* Removal	> 93%

\* Total Petroleum Hydrocarbons

Information on the pollutant removal efficiency of the filter soil/plant media is based on third party lab and field studies.

Filtterra media has been TAPE and TARP tested and approved.

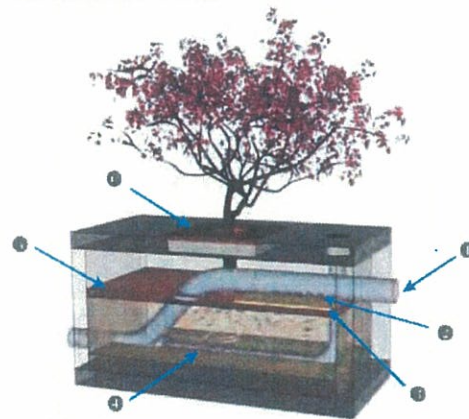

1. Influent Pipe from Roof Leader
2. Erosion Control Device
3. Protective Mulch Layer
4. Perforated Underdrain for Treatment Flows
5. Cast Iron Tree Grate for Maintenance Access



**Filtterra® Stormwater Bioretention Filtration System**  
 The Urban Solution for LID

**Standard Filtterra® System**

The Standard Filtterra® System is similar in concept to bioretention in its function and applications but has been optimized for high volume/flow treatment and high pollutant removal. Its small footprint allows it to be used on highly developed sites such as landscaped areas, parking lots and streetscapes. Filtterra® is exceedingly adaptable and can be used alone or in combination with other BMPs.

Stormwater runoff enters the Standard Filtterra System through a curb-inlet opening and flows through a specially designed filter media mixture contained in a landscaped concrete container. The filter media captures and immobilizes pollutants; those pollutants are then decomposed, volatilized and incorporated into the biomass of the Filtterra® system's micro/macro fauna and flora. Stormwater runoff flows through the media and into an underdrain system at the bottom of the container, where the treated water is discharged.

**Features and Benefits**

**Best Value.** Filtterra offers the most cost effective stormwater treatment system featuring low cost, easy installation and simple maintenance.

**Regulatory Compliance.** Third party field testing confirmed that Filtterra meets state regulatory requirements for pollutant removal under TAPE and TARP testing.

**Aesthetics.** Landscaping enhances the appearance of your site making it more attractive while removing pollutants.

**Maintenance.** Maintenance is simple and safe (no confined space access), and the first year is FREE with the purchase of every unit.

**Versatile.** Filtterra is ideal for both new construction and urban retrofits, as well as:

- Streetscapes
- Parking lots
- Highways
- Urban settings
- Daylighted Roof drains
- Industrial settings

**Design Support.** Our engineers can assist you with all aspects of each Filtterra application, including flora selection and sizing.<sup>1</sup>

**A Highly Effective System**

Filtterra is well-suited for the ultra-urban environment with proven high removal efficiency for many toxic substances such as petroleum and heavy metals.



Filtterra® monitoring unit at an industrial port.

The Filtterra System meets or exceeds federal and state regulatory guidelines for pollutant removal efficiencies of Total Suspended Solids (TSS), nutrients and metals.

**Expected Pollutant Removal**

(Ranges Varying with Particle Size, Pollutant Loading and Site Conditions)

TSS Removal	85%
Phosphorus Removal	60% - 70%
Nitrogen Removal	43%
Total Copper Removal	> 58%
Dissolved Copper Removal	46%
Total Zinc Removal	> 66%
Dissolved Zinc Removal	58%
Oil & Grease	> 93%

Information on the pollutant removal efficiency of the filter soil/plant media is based on third party lab and field studies.

**Filtterra media has been TAPE and TARP tested and approved.**

<sup>1</sup>For more details, see the Sizing Table for your project's region.

K-FTNW

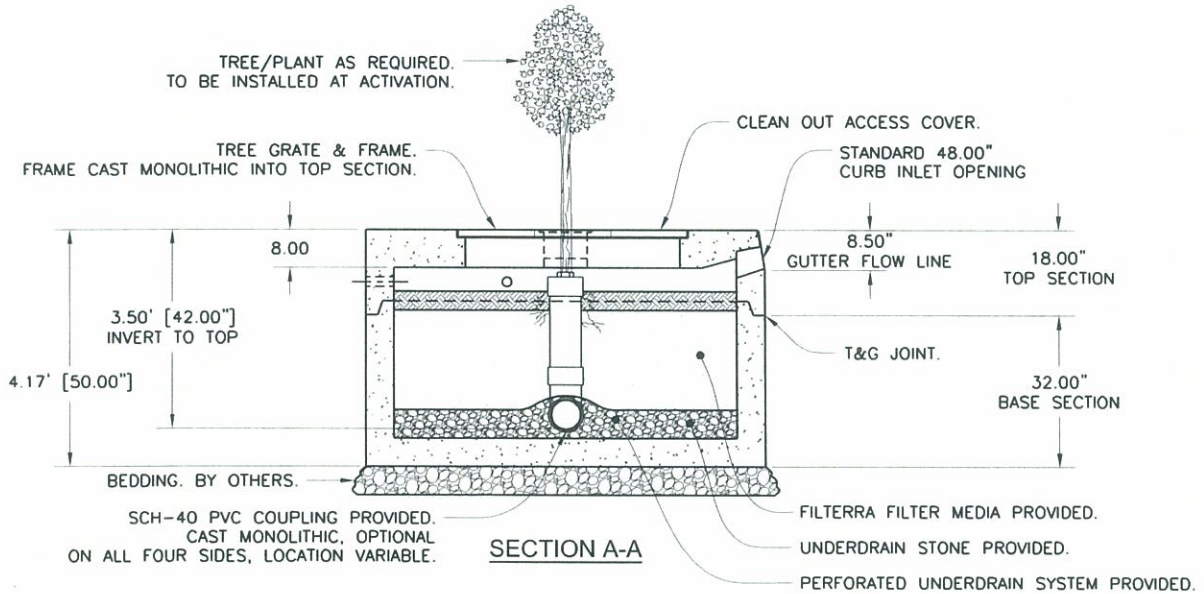
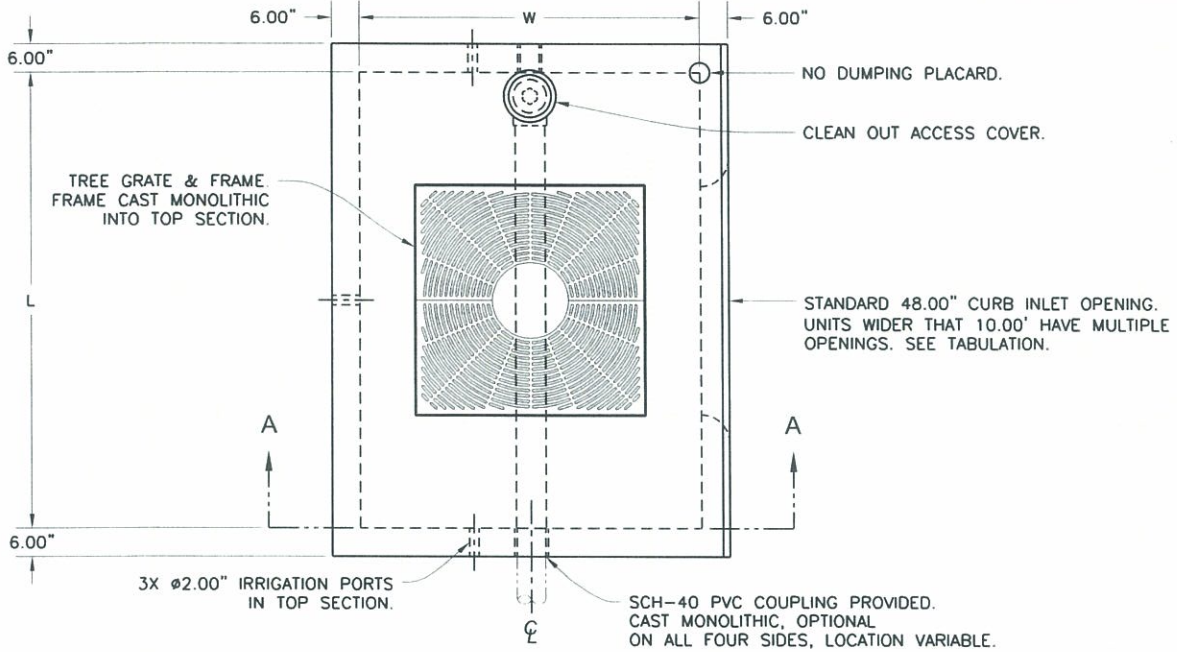

**TABULATION**

Size / Designation	L (Feet)	W (Feet)	Tree Grate Quantity / Size	Outlet Pipe PVC SCH-40	Inlet Openings Quantity / Size
6' X 4'	6.00'	4.00'	1ea. / 3' x 3'	Ø4.00"	1ea. / 48.00"
6.5' x 4'	6.50'	4.00'	1ea. / 3' x 3'	Ø4.00"	1ea. / 48.00"
8' x 4'	8.00'	4.00'	1ea. / 3' x 3'	Ø4.00"	1ea. / 48.00"
8' x 6'	8.00'	6.00'	1ea. / 4' x 4'	Ø4.00"	1ea. / 48.00"
10' x 6'	10.00'	6.00'	1ea. / 4' x 4'	Ø6.00"	1ea. / 48.00"
12' x 6'	12.00'	6.00'	2ea. / 4' x 4'	Ø6.00"	2ea. / 48.00"
12' x 8'	12.00'	8.00'	2ea. / 4' x 4'	Ø6.00"	2ea. / 48.00"
16' x 4'	16.00'	4.00'	2ea. / 3' x 3'	Ø4.00"	2ea. / 48.00"
16' x 8'	12.00'	8.00'	2ea. / 4' x 4'	Ø6.00"	2ea. / 48.00"
18' x 8'	12.00'	8.00'	3ea. / 4' x 4'	Ø6.00"	3ea. / 48.00"
20' x 8'	20.00'	8.00'	3ea. / 4' x 4'	Ø6.00"	3ea. / 48.00"

MODIFICATION OF DRAWINGS IS PERMITTED ONLY BY WRITTEN AUTHORIZATION FROM KRISTAR ENTERPRISES, INC.

TITLE

# Precast Filterra® Unit Narrow Width Configuration



**KriStar Enterprises, Inc.**

360 Sutton Place, Santa Rosa, CA 95407  
Ph: 800.579.8819, Fax: 707.524.8186, www.kristar.com



DRAWING NO.  
**K-FTNW**

REV  
**03**

F-ECO  
**0006 JPR 6/17/11**

DATE  
**JPR 1/7/11**

-FTST

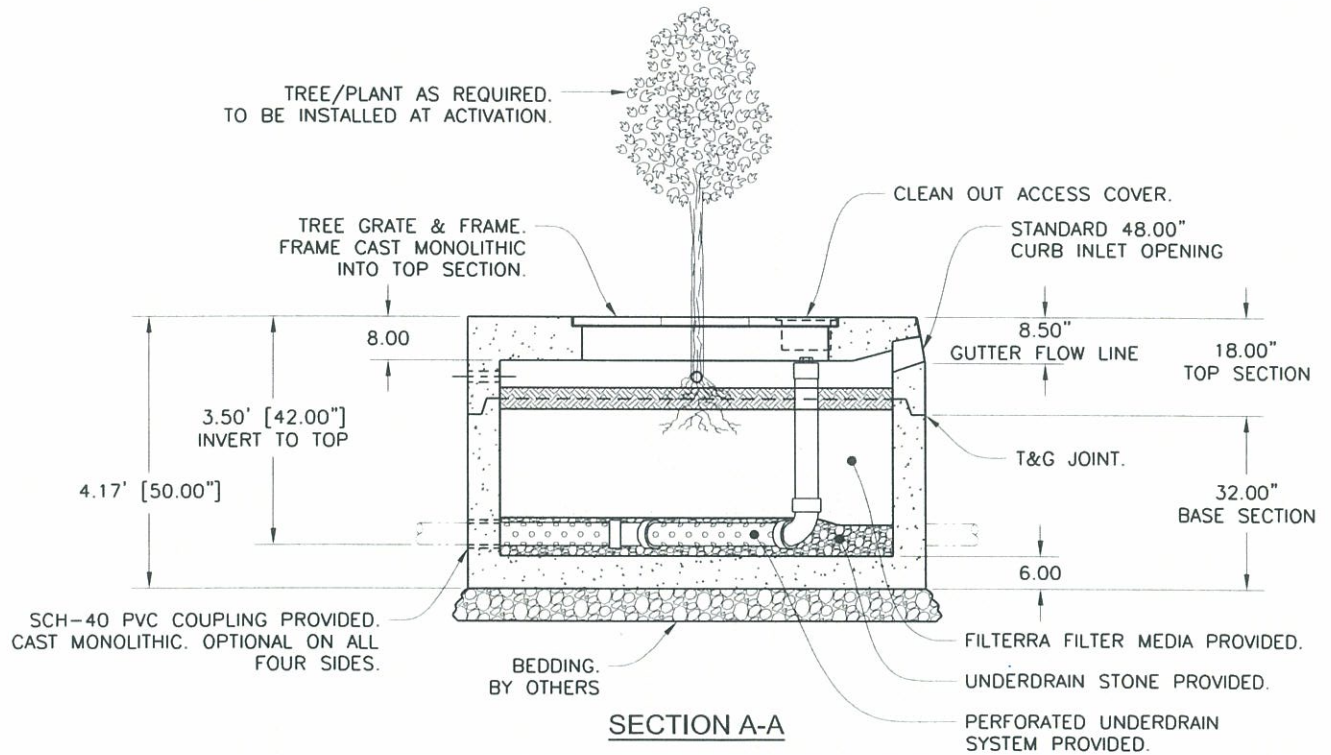
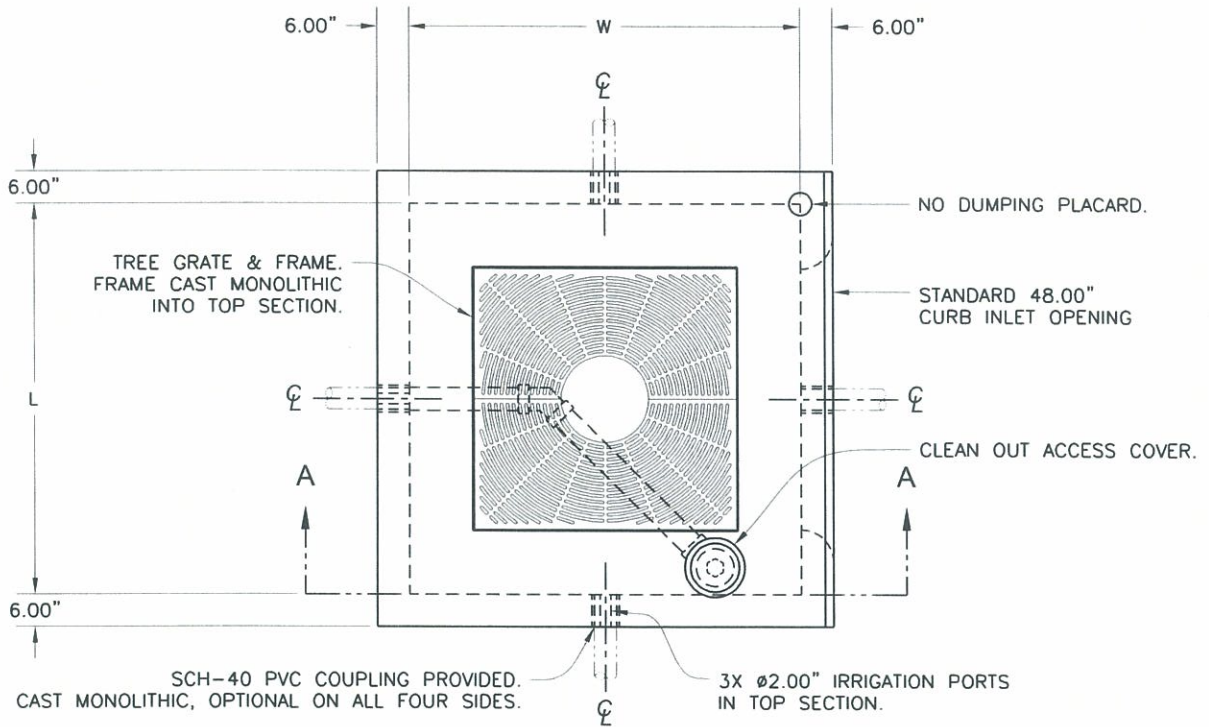

TABULATION				
Size / Designation	L (Feet)	W (Feet)	Tree Grate Quantity / Size	Outlet Pipe PVC SCH-40
4' x 4'	4.00'	4.00'	1Ea. / 3' x 3'	Ø4.00"
6' x 6'	6.00'	6.00'	1Ea. / 3' x 3'	Ø4.00"

MODIFICATION OF DRAWINGS IS PERMITTED ONLY BY WRITTEN AUTHORIZATION FROM KRISTAR ENTERPRISES, INC.

**Precast Filterra® Unit**  
**Standard Configuration (Square)**



**KriStar Enterprises, Inc.**  
 360 Sutton Place, Santa Rosa, CA 95407  
 Ph: 800.579.8819, Fax: 707.524.8186, www.kristar.com



DRAWING NO. K-FTST	REV 03	F-ECO 0006 JPR 6/17/11	DATE JPR 1/7/11
-----------------------	-----------	---------------------------	--------------------

### **HYDRODYNAMIC SEPARATION DEVICE (PRE-1) - CDS Unit - BMP-5:**

#### **Pre-treatment, upstream Treatment-train Upstream of Underground Detention Basin**

HDS products work well as standalone or end-of-pipe treatment systems and can easily be implemented in a retrofit scenario. They are particularly effective at removal of solids, trash and debris – and can help you meet TMDL requirements for these pollutants. HDS systems are also optimal pretreatment systems – and an important building block in a low impact development (LID) design. By removing solids, trash and debris prior to detention, infiltration or re-use systems, you can significantly increase their service life.

#### **Water Quality**

HDS products provide high-performance stormwater pollutant removal. These systems are effective in removing solids to meet water quality goals and can be designed to achieve site treatment goals for TSS or oil.

#### **Pretreatment for Low Impact Development (LID) Designs**

Hydrodynamic separation systems installed as pretreatment reduce downstream loading to reduce maintenance

#### **Inlet and Outlet Pollution Control**

Our HDS products are especially effective for solids and trash and debris. They can be installed at either the inlet or outlet of a drainage system to prevent pollutants from being discharged into lakes, streams or the ocean.



*A Vortechs protects detention system from sediment build-up and reduces maintenance*



*CDS unit installed to remove trash before entering Lake Meritt in Oakland, CA*



*VortSentry HS is an effective option where space is limited*

The CDS is a swirl concentrator hybrid technology that provides continuous deflective separation – a combination of swirl concentration and patented indirect screening – into a uniquely capable product. It effectively screens, separates and traps debris, sediment and oil from stormwater runoff and is an ideal system to meet trash Total Maximum Daily Load (TMDL) requirements.

## Features & Benefits

### One-of-a-Kind Screening Technology

- Captures and retains 100% of floatables and neutrally buoyant debris 2.4mm or larger
- Effectively removes solids down to 100µm
- Self-cleaning screen – the only non-blocking screening technology available
- Water velocities within the swirl chamber continually shear debris off the screen to keep it clean
- Various screening apertures available

### Proven Performance

- Performance verified by NJ CAT and WA Ecology

### Excellent Pollutant Retention

- Isolated Storage Sump eliminates scour potential
- Oil Baffle improves hydrocarbon removal

### Multiple Options to Meet Site-Specific Needs

- Inline, offline, grate inlet and drop inlet configuration
- Accepts multiple pipe inlets and 90-180° angles – eliminate the need for junction manholes
- Internal and external peak bypass options available
- High treatment flow capacity – up to 300 cfs

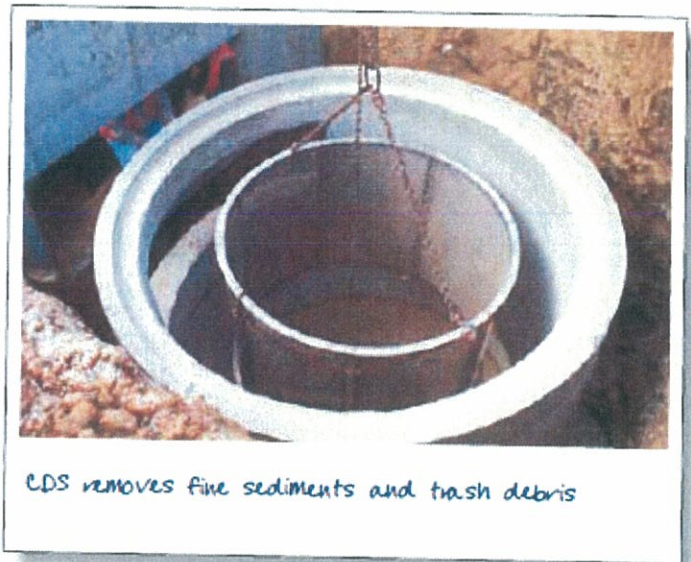
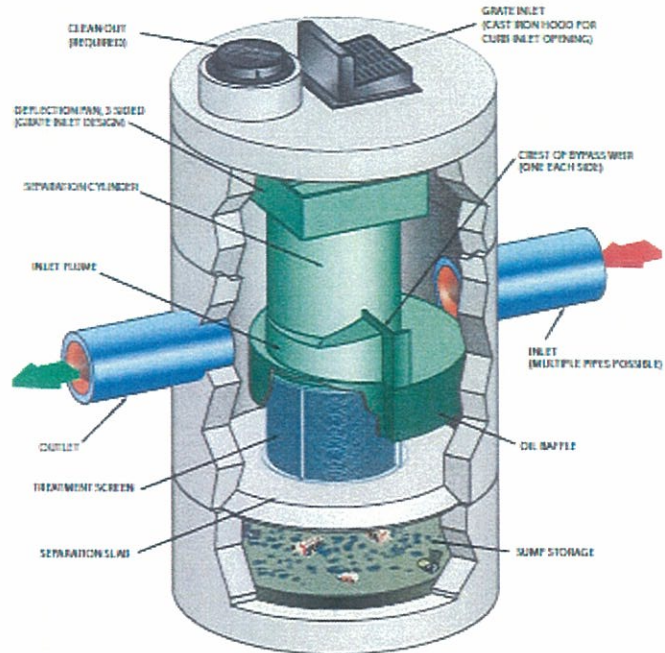

CDS removes fine sediments and trash debris

## Design Basics

There are three primary methods of sizing a CDS system. The Water Quality Flow Rate Method determines which model size provides the desired removal efficiency at a given flow rate for a defined particle size. The Rational Rainfall Method<sup>TM</sup> and Probabalistic Method are used when a specific removal efficiency of the net annual sediment load is required.

Typically in the Unites States, CDS systems are designed to achieve an 80% annual solids load reduction based on lab generated performance curves for a gradation with an average particle size (d50) of 125-microns ( $\mu\text{m}$ ). For some regulatory environments, CDS systems can also be designed to achieve an 80% annual solids load reduction based on an average particle size (d50) of 75-microns ( $\mu\text{m}$ ).

### Water Quality Flow Rate Method

In many cases, regulations require that a specific flow rate, often referred to as the water quality design flow (WQQ), be treated. This WQQ represents the peak flow rate from either an event with a specific recurrence interval (i.e. the six-month storm) or a water quality depth (i.e. 1/2-inch of rainfall).

The CDS is designed to treat all flows up to the WQQ. At influent rates higher than the WQQ, the diversion weir will direct most flow exceeding the treatment flow rate around the separation chamber. This allows removal efficiency to remain relatively constant in the separation chamber and reduces the risk of washout during bypass flows regardless of influent flow rates.

Treatment flow rates are defined as the rate at which the CDS will remove a specific gradation of sediment at a specific removal efficiency. Therefore they are variable based on the gradation and removal efficiency specified by the design engineer.



CDS Model	Diameter		Distance from Water Surface to Top of Sediment Pile		Sediment Storage Capacity	
	ft	m	ft	m	yd <sup>3</sup>	m <sup>3</sup>
CDS2015-4	4	1.2	3.0	0.9	0.5	0.4
CDS2015	5	1.5	3.0	0.9	1.3	1.0
CDS2020	5	1.5	3.5	1.1	1.3	1.0
CDS2025	5	1.5	4.0	1.2	1.3	1.0
CDS3020	6	1.8	4.0	1.2	2.1	1.6
CDS3030	6	1.8	4.6	1.4	2.1	1.6
CDS3035	6	1.8	5.0	1.5	2.1	1.6
CDS4030	8	2.4	4.6	1.4	5.6	4.3
CDS4040	8	2.4	5.7	1.7	5.6	4.3
CDS4045	8	2.4	6.2	1.9	5.6	4.3

Table 1: CDS Maintenance Indicators and Sediment Storage Capacities

Note: To avoid underestimating the volume of sediment in the chamber, carefully lower the measuring device to the top of the sediment pile. Finer silty particles at the top of the pile may be more difficult to feel with a measuring stick. These finer particles typically offer less resistance to the end of the rod than larger particles toward the bottom of the pile.

### 6.3.2 SIZING

Design Capture Storm Depth = 0.80 inches

