

## 1. Street Trees

Dana Point's landscape character should be strengthened by street tree planting throughout the City.

Many street rights-of-way already have one or more dominant tree species. If the existing tree species are well established and suited to the area, it is recommended that new planting continue the same species.

### a. General Guidelines

*Tree selection should emphasize drought tolerance with minimal watering required after an initial establishment period of 3 to 5 years.*

- Street trees should be installed with all new development and planted at a minimum regular interval of approximately 40 feet, except where driveway or utility locations prohibit.
- Locate street trees carefully near driveway openings to insure visibility of oncoming traffic.
- Trees should be a minimum 24 inch box size. In the case of Palms, they should be at least 10 feet high.
- Existing street trees that are retained may substitute for the street tree requirement.
- All street tree selections are subject to City approval.

### b. Commercial Street Guidelines

Commercial areas benefit from street trees. Trees provide shade, a visual theme, softening of buildings, and aesthetic contributions of beauty, form, and color. Height and density of leaf canopy are important considerations within commercial districts. Pedestrians should be able to walk freely among street tree plantings, with storefront signage visible beneath or between street tree canopies.

Taller trees may be used in areas of higher buildings, or to emphasize focal points in the City.

### c. Residential Street Guidelines See comment 24

Street trees in residential neighborhoods should be chosen primarily for their aesthetic characteristics. The tree form, texture of leaves, flowering habits, and color of foliage are important considerations.

The form, height, and location of street trees should be carefully selected to preserve public views of the ocean and other significant scenic features. See Section IV.B.

See comment 25

## 2. Landscaped Areas

- Courtyards and other pedestrian spaces are encouraged on developed sites. Courtyards should be pleasant pedestrian-oriented spaces with opportunities for outdoor passive activities.
- Trees should be planted within courtyards to create shade and define spaces. Perimeter plants may be used to soften the space between paving and buildings. Where it is not possible to plant trees, trellises and arbors are encouraged to provide shade and human scale.
- Tile and decorative paving are encouraged. Concrete pavers, stone, brick or tile may be used as banding for concrete slabs.

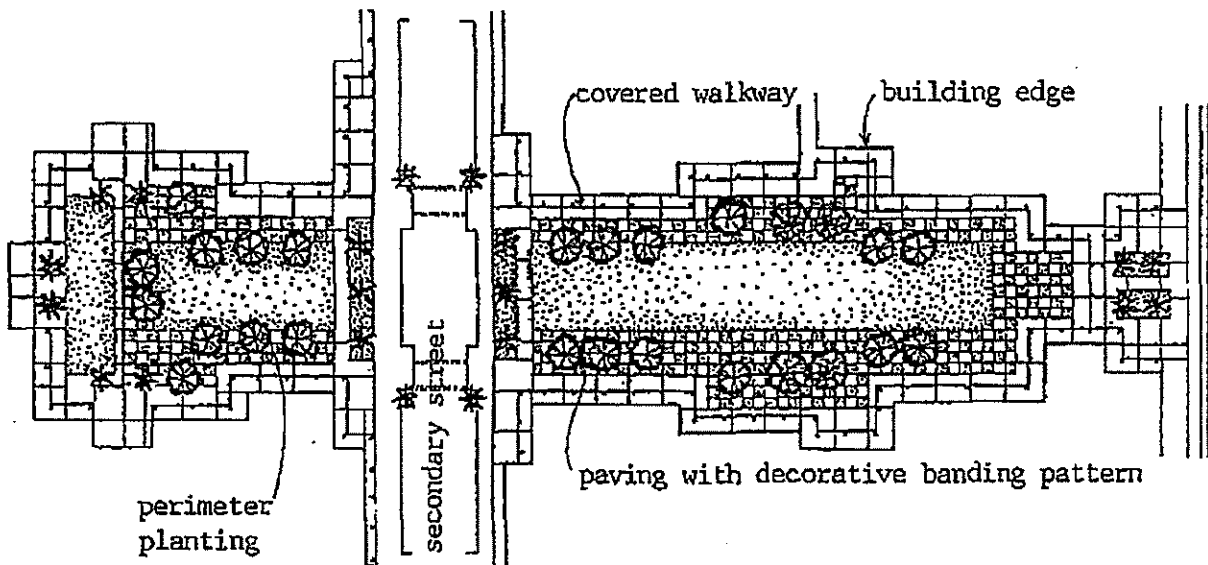

Illustrative Courtyard Design.

- Walls and planters should blend with the development's architecture so they become extensions of the buildings. For example, the materials used on the face of a building may be used to face a courtyard wall.
- Large turfed lawn areas can require significant amounts of water, and are therefore discouraged in developments except for high-use public recreational areas, or as supplemental or accent landscaping.
- Landscaped areas are encouraged to be designed to utilize reclaimed water. Where reclaimed water is currently not available, landscaped areas should be designed to accept reclaimed water as soon as it is available.

## II.E. Historic Preservation

*The process of creating a historic preservation program involves two stages. The first stage is inventorying buildings and sites which may have historic or architectural significance. The second stage is the property owner enrolling the property in the historic preservation program by offering to designate it a historic site or structure. Designated buildings and sites of historic or architectural significance should be preserved. The rehabilitation of other buildings and sites of historic or architectural merit is encouraged.*

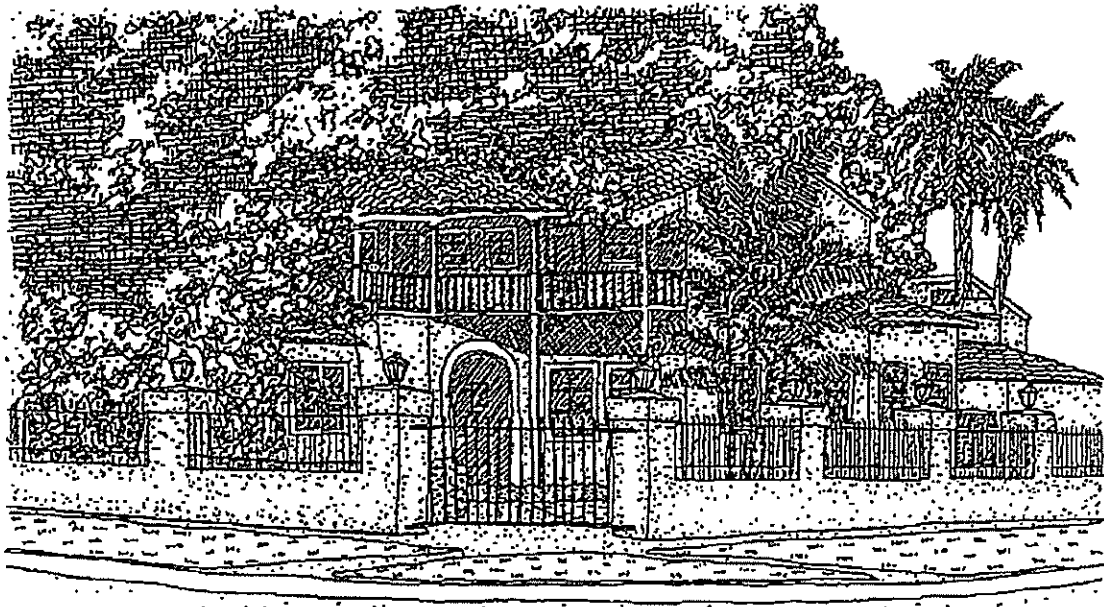

See comment 26

### 1. Designated Historic Site

- A Designated Historic Site may be of national, state or local significance. There are procedures for pursuing restoration and rehabilitation. The Community Development staff of the City of Dana Point should be contacted for assistance.
- The Secretary of the Interior's "*Standards for Rehabilitation and Guidelines for Rehabilitating Historic Buildings*" published by the U. S. Department of the Interior, National Park Service, should be reviewed and used.

The following Guidelines should be used for Designated Historic Sites. In addition, follow the guidelines for compatibility listed in Section II.B. "Relationship to Neighboring Development."

- a. **Compatibility With Historic Resources.** New development should be compatible with existing historic resources. Particular emphasis should be placed on achieving a compatible scale and positive relationship with historic craftsmanship.

*substantiated by historic, physical, or pictorial evidence rather than on conjectural designs or the availability of different architectural elements from other buildings or structures.*

- 7) *The surface cleaning of structures shall be undertaken with the gentlest means possible. Sandblasting and other cleaning methods that will damage the historic building materials shall not be undertaken.*
  - 8) *Every reasonable effort shall be made to protect and preserve archaeological resources affected by, or adjacent to, any project.*
  - 9) *Contemporary design for alterations and additions to existing properties shall not be discouraged when such alterations and additions do not destroy significant historical, architectural or cultural material, and such design is compatible with the size, scale, color, material, and character of the property, neighborhood or environment.*
  - 10) *Wherever possible, new additions or alterations to structures shall be done in such a manner that if such additions or alterations were to be removed in the future, the essential form and integrity of the structure would be unimpaired.*
- Preservation and careful rehabilitation of a designated historic building may enable the owner to take advantage of special allowances of the *California State Historic Building Code* as well as Federal tax incentives.

## 2. Undesignated Historic Sites

- If a building or site exhibits a character that contributes to Dana Point's history but does not necessarily qualify for national, state or local historic designation, the following guidelines should be followed:
  - Retention of the existing historic structure is encouraged. Consider additions and/or adaptive reuse designed for compatibility with the original structure.
  - New buildings which are built adjacent to buildings of historic character should consider the compatibility of details, materials, textures, colors, and landscape features. See Section II.B.

## II.F. Parking and Loading Facilities

### 1. Access

- Minimize the number of driveway openings on public streets, particularly on major arterials. Shared or joint use driveways between separate properties are encouraged. This will help reduce traffic congestion by encouraging internal circulation.
- On major arterials, corner properties should provide access from side streets when possible.
- Provide adequate distance between driveways.
- Access for service vehicles, trash collection and storage areas should be located on alleys where possible. When no alley exists, the access should be located on the street with least traffic volume.

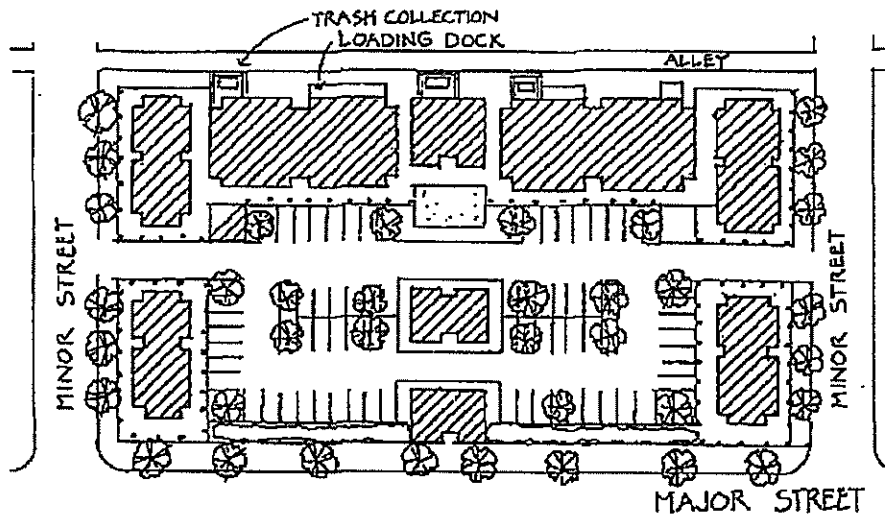

### 2. Surface Parking

- Parking lots should be organized into smaller parking courts with landscaping and clear, attractive pedestrian pathways to buildings.
- Off-street parking lots should be softened from street view by planting or a combination of planting, low walls or planted earth berms.

A continuous screen at least 30 inches high should be formed by a solid wall or planting. If shrubs are used to create the screen, the shrubs should be a minimum of 30 inches in height after two years growth. Space shrubs in massed plantings so that branches intertwine. Solid walls used for screening should be integrated with planter boxes or accompanied by a minimum 3 foot wide landscaped edge facing the street. The continuous planting screen shall take into consideration sight visibility as required by the City Engineer.

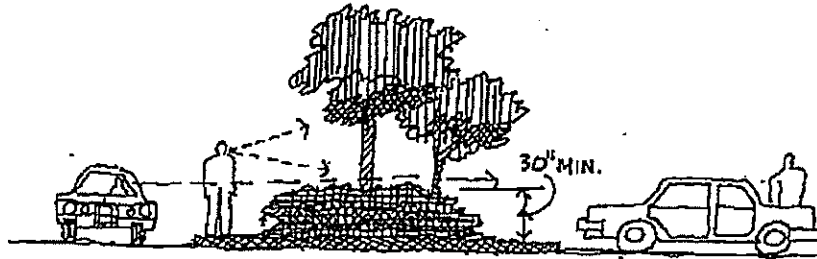

Section. Parking lot perimeter screening.

- Landscaped perimeter areas of parking lots should be a minimum of 10 feet deep along public streets. The depth of the landscaped perimeter should be increased for larger parking lots and sites.
- Parking spaces and lots should be set back at least 5 feet from the face of a building. The 5 foot area between the parking space and building should be used as a pedestrian walkway, or fully landscaped.

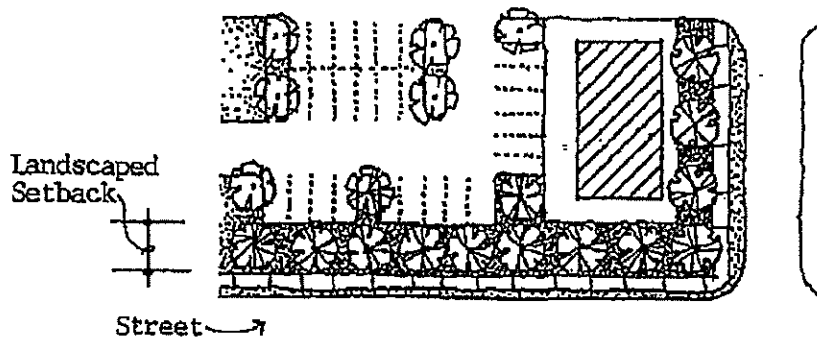

Plan. Parking lot setback with planting.

- Landscaped areas within parking lots as required by Chapter 9.35 of the Dana Point Zoning Code are not ~~be~~ included in the calculation of minimum landscape coverage.

- Guidelines for Parking Lot Landscaping

The following guidelines should be incorporated in the design of landscaping for parking lots:

- Landscaped areas should be distributed throughout the entire parking areas as evenly as is appropriate in the design of the parking facility.
- All landscaped areas should be designed so that plant materials are protected from vehicle damage, encroachment, or overhang.
- Any open areas in the interior of the parking lot should be landscaped with appropriate plant materials and maintained in good condition as provided in Section 9.55.030(d).

- Minimum Requirements for Parking Lot Landscaping

All parking lot landscaping should be designed to meet the following guidelines:

- All landscaping within a parking lot should be located in planter areas which are bounded by concrete curbing. All required curbing for planter areas shall be at least six inches (6") high and six inches (6") wide.
- Landscaped planters should be placed adjacent to any parking stall at the end(s) of an interior row of parking stalls.
- Excluding curbing, all required planter areas should be at least four feet (4') wide and at least 25 square feet in area. Each planter should be supplied with appropriate irrigation.
- The landscape plan should include a minimum of one (1) tree for every six uncovered stalls in the parking lot.
- The distance between any two planter areas in the same row of parking stalls should not exceed the width of eight (8) adjacent parking stalls or a maximum of 72 feet.
- Parking lots with twelve (12) or more uncovered parking stalls should be designed so that the minimum amount of landscaping provided in the interior of the parking lot is equal to ten percent (10%) of the parking lot area. Said landscaping should be provided in accordance with the following guidelines:

Parking lot area means the paved area of the parking lot provided for the parking and circulation of motor vehicles, including all parking stalls, parking aisles, internal driveways and entry driveways.

To be considered toward the requirement for interior parking lot landscaping, the proposed landscaping should satisfy the minimum dimensional and locational standards noted above and fall into one of the following categories:

- a. Landscape islands provided between parking stalls or at the end of a row of parking stalls in the interior of the parking lot.

## II.G. Building Equipment and Services

*Locate and design building services and equipment to minimize their visual impact on public streets and neighboring properties.*

### 1. General Guidelines

- Access for service vehicles and trash collection should be located on alleys where possible.
- Trash/recycling containers and outdoor storage areas should be visually screened from public streets, pedestrian areas and neighboring properties. The screen for trash containers should be compatible with the architectural character of the development and be of durable materials. Roofed storage areas are encouraged.
- When feasible in larger commercial developments, service and loading areas should be separated from the main circulation and parking areas.
- Mechanical equipment, solar collectors, satellite dishes, communication devices and other equipment should be concealed from view of public streets, adjacent properties and pedestrian areas.
- Roof-mounted mechanical equipment should be minimized. When used, it should be screened from view. Special attention should be given to buildings whose roofs are viewed from higher elevations. The design of these buildings should integrate the rooftop equipment into the design of the roof. It is often possible to create a "well" within the structure or a penthouse on top of the structure that is visually integrated with the main building.

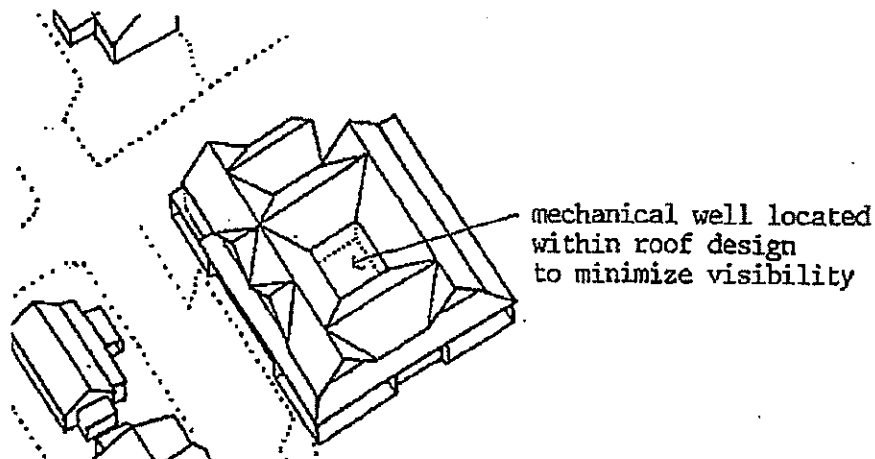

Mechanical well integrated within roof.



### III.A. Residential Development    See comment 27

*Attached Single-Family, Duplex, and Multi-Family developments should contribute to the sense of community in their neighborhoods by carefully relating to the open spaces, scale and form of adjacent properties, and by providing street frontages that create architectural and landscape interest.*

The Design Guidelines in this section apply to projects of 3 or more attached dwellings.

#### 1. Site Planning Guidelines

##### a. Clear Site Organization and Sense of Address

The site's organization should provide direct visual relationships between buildings, streets, and sidewalks.

- Individual dwellings should be oriented toward the street, interior courtyards, or garden spaces. If most of the dwelling units are oriented toward open spaces within the site, it is preferable that some dwellings be oriented directly to the public street and sidewalk.
- Each dwelling should have a "sense of address," either toward the street or directly to an interior open space on the site. Hidden dwellings to the rear of buildings, or units opening to parking lots, are discouraged.

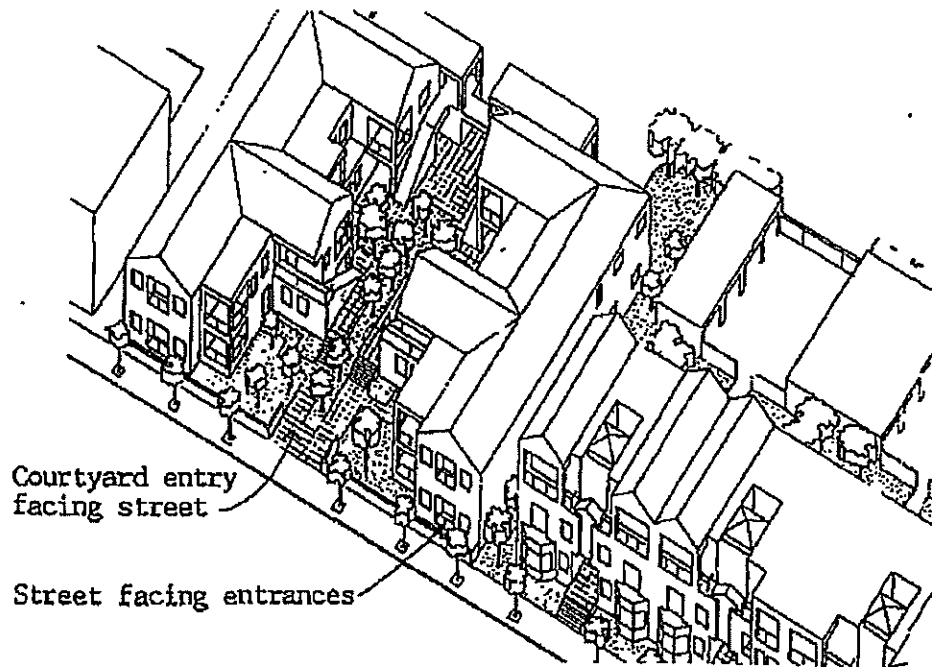

Illustration. "Sense of Address." Courtyard and Townhouse Dwellings.

- Private streets and drives.
  - Provide a sidewalk or pedestrian path on at least one side of a private street.
  - Create landscaped yard spaces between the buildings and the private street.
  - Minimize the visual impact of garage doors, refuse containers, and other service facilities along private streets, unless the street is used exclusively as a service drive or alley.

## 2. Open Space

### a. Private Open Space See comment 28

Dana Point's climate is ideal for outdoor living. Residential development should take advantage of this special opportunity by providing usable open space for each dwelling.

- Balconies and verandas are encouraged to provide upper level private open space.
- Open spaces should provide privacy from adjacent dwellings and public streets.
- Outdoor spaces oriented to views and good sun penetration are encouraged.

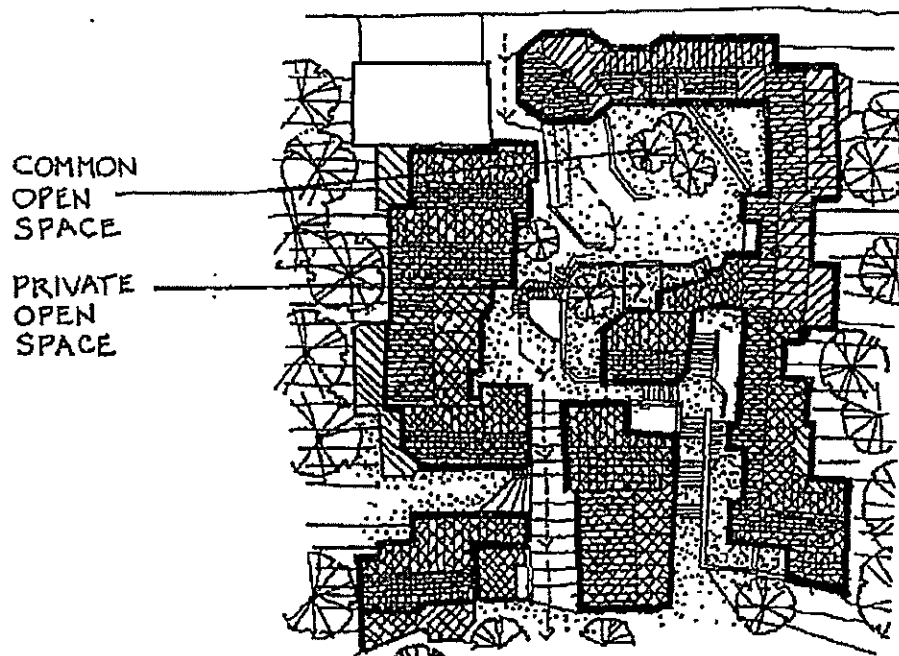

Private and Common Open Space.

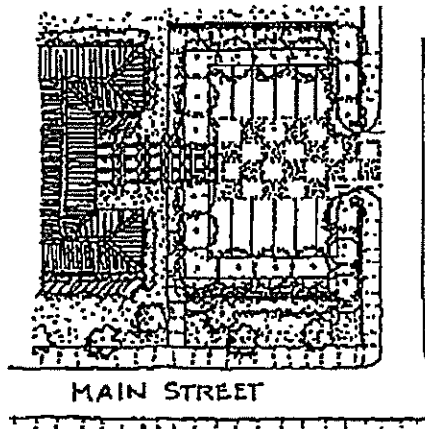

Parking Court

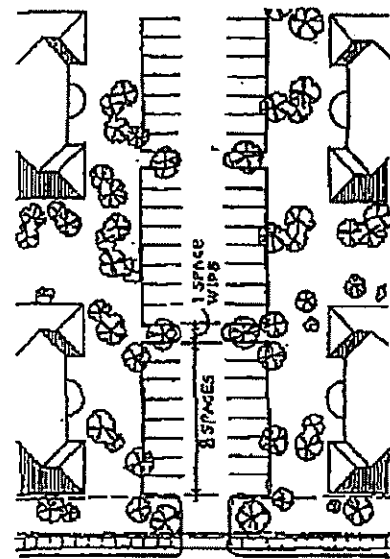

Parking Drive

## 5. Landscaping

- All yard and setback spaces should be fully landscaped with trees and shrubs. Decorated paved courtyards and playgrounds may be considered acceptable substitutes for planted space if determined a positive design addition and if sufficient landscaping is provided for the site. At least one tree, minimum 24-inch size, should be planted for each 300 square feet of required landscaped area.
- Landscape buffers and screens between residential development and undesirable abutting land uses are strongly encouraged. Trees, shrubs, earth mounds, and fences are also useful in buffering unwanted noise and views from streets and parking lots.
- **Parking Lot Screening.** Views of surface parking lots from public streets, adjacent properties, and open spaces should be screened by a combination of trees and shrubs. See Section II.F, "Parking and Loading Facilities."

See comment 29

### III.B. Commercial, Mixed-Use and Office Development

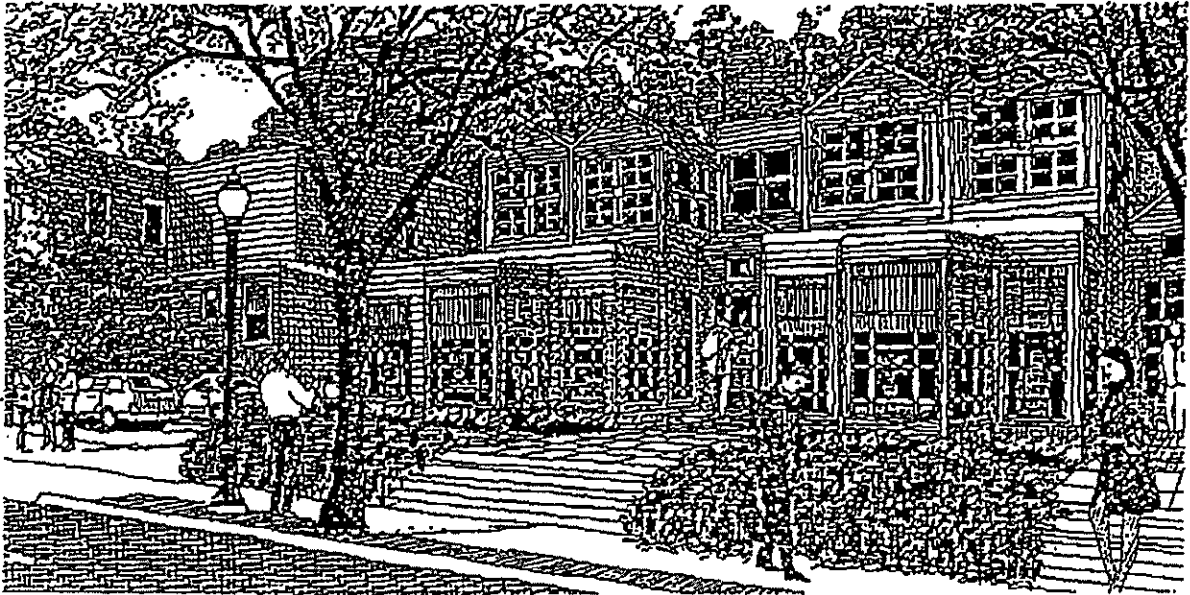

#### 1. Site Planning

- Orient principal building elevations toward public streets and sidewalks. Avoid blank walls, large parking lots and other elements that lack pedestrian interest along the street edge.
- Design visual and circulation linkages between adjacent developments to create design continuity along public streets. Visual continuity can be achieved through similar building forms, heights, materials, landscape patterns and signage. Circulation linkages can be achieved by connected walkways and shared driveways.
- Minimize the number of curb cuts for driveways. Use alley access to parking when possible.
- See Section II.F. "Parking and Loading Facilities."
- Multi-building shopping centers should locate some buildings along the sidewalk. This pattern will create pedestrian interest at the sidewalk while allowing for ample parking lot visibility and access from the street.

See comment 30

### Summary of Design Principles

- Place as much of the ground level elevation of the building as possible on or near the front property line to maintain the continuity of the street edge. See comment 30A
- Courtyards, plazas, patios and other pedestrian spaces are encouraged along building frontages and at other locations in the development.
- Provide active building frontages at ground level.
- Provide frequent street facing pedestrian entrances.
- Locate parking to the rear or side of buildings.
- Plant trees along the street edge in a rhythmic pattern.
- Where appropriate, widened sidewalk spaces may be used for street furniture and planting.
- Create small-scale building frontages by dividing building facades into smaller parts.
- The building wall at the street should be limited to two stories.

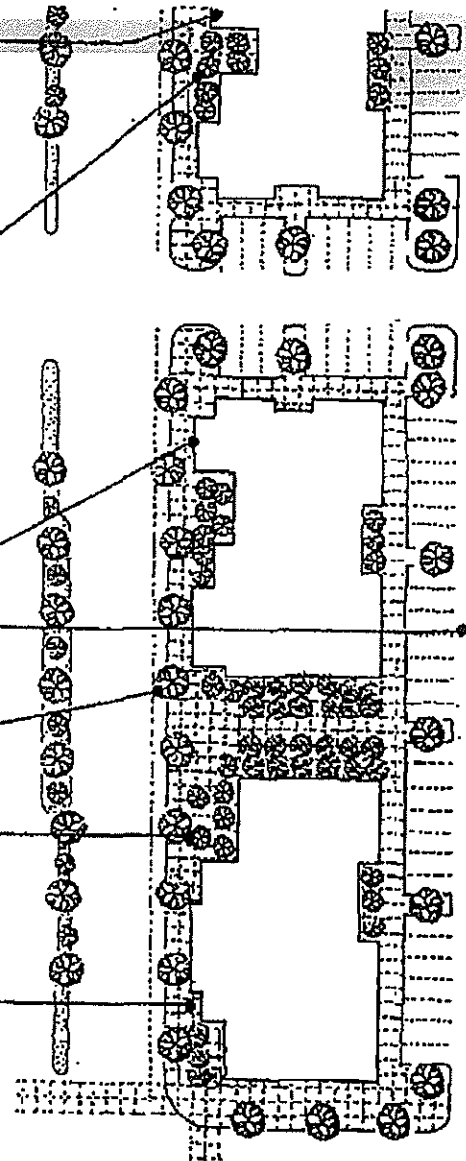

### III.C. Industrial and Business Park Development

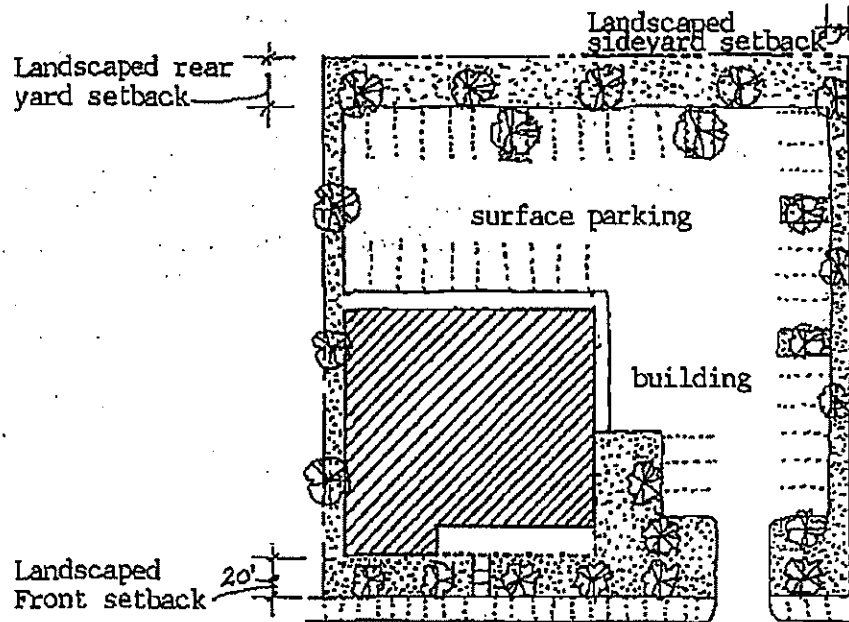

Illustrative Site Plan.

#### 1. Site Planning and Landscaping

- Provide a minimum 20 foot Landscaped Street Edge along all public streets. The Landscaped Street Edge should be composed of plantings, earth berms, and/or low walls. Storage yards, loading areas, parking, or similar uses should not be located in this area.
- Trees: At least one tree should be provided for each 300 square feet of total area of the Landscaped Street Edge. Trees should be 24-inch box minimum size.
- Shrubs: Shrub planting should be used for screening and ornamental purposes.

When shrubs are used for screening, they should provide a visual screen of minimum height of 5 feet after 2 years growth. Shrubs and walls should not obstruct views of oncoming traffic at driveways.

#### 2. Screening

- Storage yards and service areas should be screened from off-site views using plantings or a combination of planting, fences and walls.

See comment 31

## IV. Additional Guidelines for Sites with Special Environmental Characteristics

See comment 32

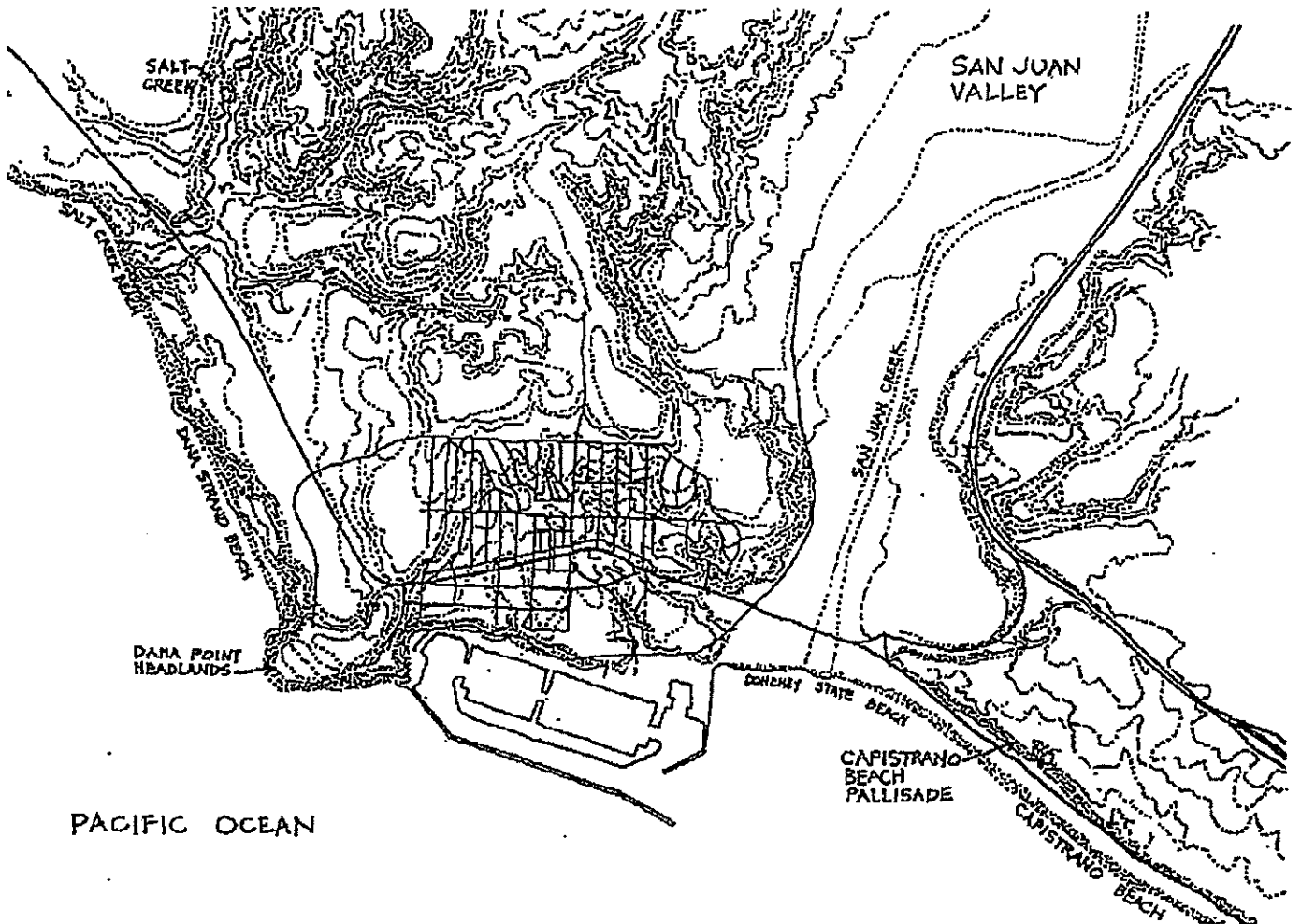

Dana Point Natural Setting

## IV.A. Multi-Building Hillside Residential Development

*These Guidelines apply to multi-building development on sloping sites subject to a Site Development Permit and/or Discretionary Design Review.*

### 1. Site Design Principles      See comment 33

- **Most sloping sites are highly visible from distant locations. Views of the site from the neighborhood and other off-site locations should be given careful consideration.**
- **Multi-building hillside residential developments should be designed with visible distinctions between buildings. This may be achieved through use of varied materials, colors, forms, roofs, facades and landscaping.**

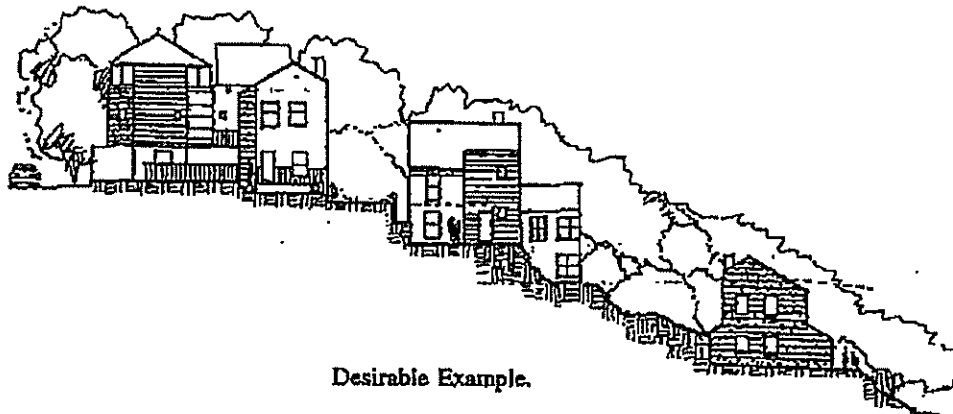
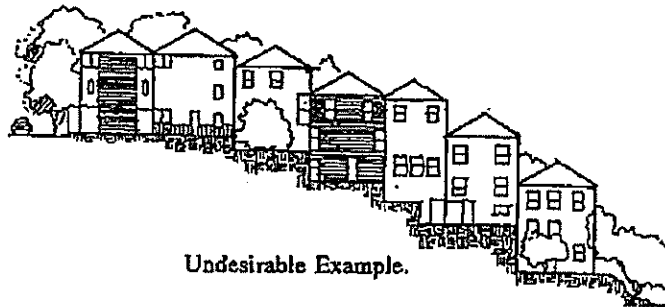

- **Height variation may be achieved by locating buildings and building elements on different levels. Avoid large continuous floor plates that require massive grading and high retaining or foundation walls.**
- **Buildings located near hillside rims have higher visibility. These buildings should be sited in a staggered arrangement and partially screened with landscaping to minimize a "wall" effect.**
- **Retain significant trees and other vegetation which contributes to the design quality of the site and surrounding area.**



2. Hillside Grading and Drainage See comment 34

- Dana Point's hillsides are an important scenic and natural resource. The design of hillside development should minimize grading impacts in the layout of streets and lots.
- Hillside grading should create slopes that approximate the surrounding natural hills.

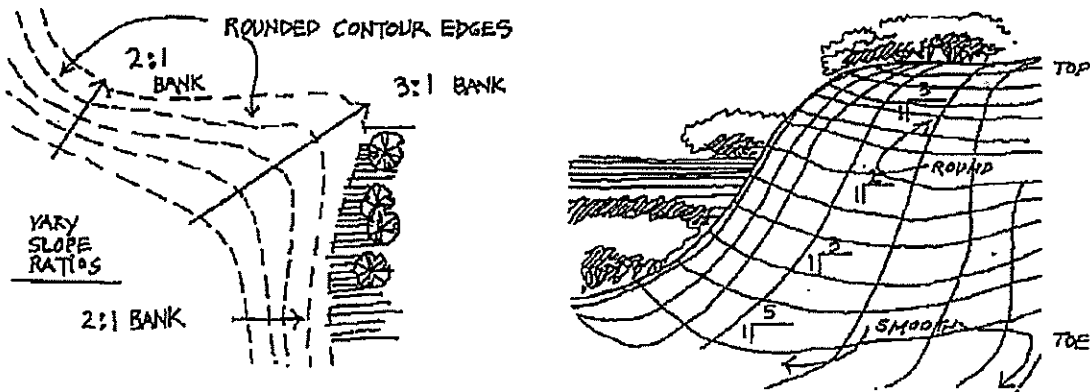

See comment 35

- Avoid an "engineered" appearance of manufactured slopes by creating smooth, flowing contours of varying gradients with slopes in an approximate range of 2:1 to 5:1. Avoid sharp cuts and fills, and long linear slopes that have a uniform grade.
- Terracing should be designed with small incremental steps, avoiding wide-step terracing and large areas of flat pads.
- New building sites should be graded to recede into the slope or to appear to emerge from the slope. Building pads should be of minimum size to accommodate the structure and a reasonable amount of adjacent outdoor space. Split-level terraces are encouraged to reduce pad size.
- Retaining walls and foundation walls visible from off-site should be of minimum height.  
See comment 36
- Drainage devices such as terrace drains, benches and downdrains should be located underground or placed in locations of least visibility on slopes. The downhill side of a drain should be bermed to conceal it. Natural swales and ravines leading downhill are a good location for downdrains. Visible drains should be as close as possible to natural soil color. Visible concrete drains should be color tinted and screened with planting.

### 3. Street Layout and Design

- **Street Layout should be aligned as closely as possible to existing grades in order to minimize the need for the grading of slopes. Natural land forms should be retained by introducing horizontal and vertical curves in road alignments, consistent with traffic and public safety standards.**

See comment 37

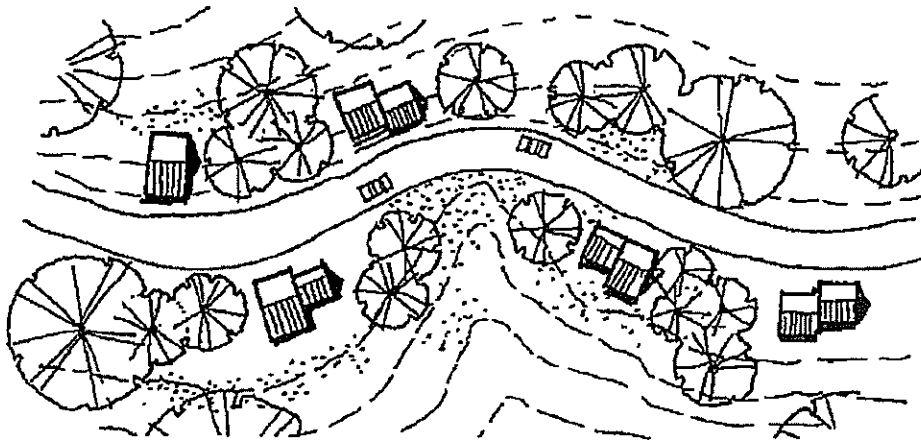

Illustration. Curved street layout aligned with slope.

- **On hillside sites where conditions permit, streets and driveways should be laid out parallel with existing topographic contours in order to minimize grading.**
- **Bridges should be considered for streets crossing natural drainage courses, canyons and ravines that are of scenic or environmental value. Large earth fills should be avoided in these locations.**
- **When streets are located on exposed hillsides viewed from a distance, cut slopes should be rounded off to approximate a natural appearance.**

#### 4. Architecture - Scale and Character

Sloping sites offer opportunities to create and enhance unique site characteristics. These opportunities include outdoor decks, terraces, roof forms, bay windows, clusters of carefully placed vegetation, lookouts for viewing, sculptured stairs, and walkways.

- Facades should be articulated and stepped back to reduce the size of building masses. Consider wall setbacks, recessed openings, porches, verandas, overhangs, projecting windows and other elements that create strong shade and shadow patterns.

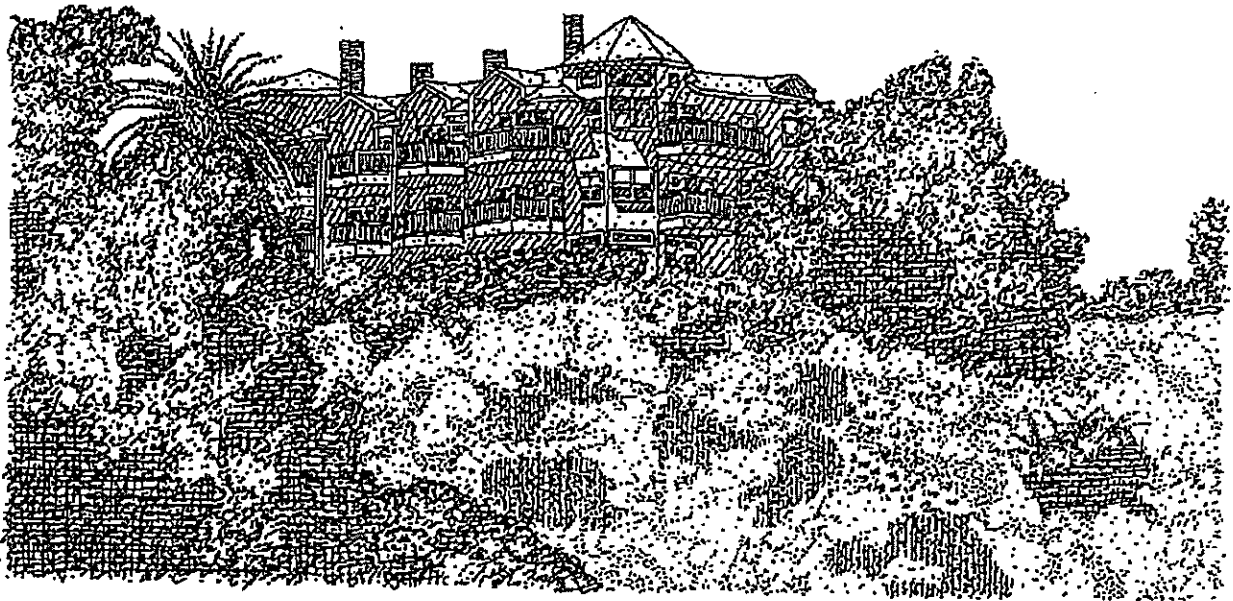

#### 5. Planting Design for Hillside

##### Common Areas

Common open spaces and landscaped areas maintained by homeowners associations are subject to review under this guideline. Provisions of this guideline are recommended for planting in other attached single-family, duplex and multi-family hillside residential development.

##### Plant Selection

- Plant materials should be selected for their effectiveness of erosion control, fire resistance, drought tolerance and ability to enhance the color and texture of the surrounding landscape.
- It is recommended that the location and heights of plantings follow downhill alignments of taller trees.

## IV.B Scenic Highways and Public View Corridors

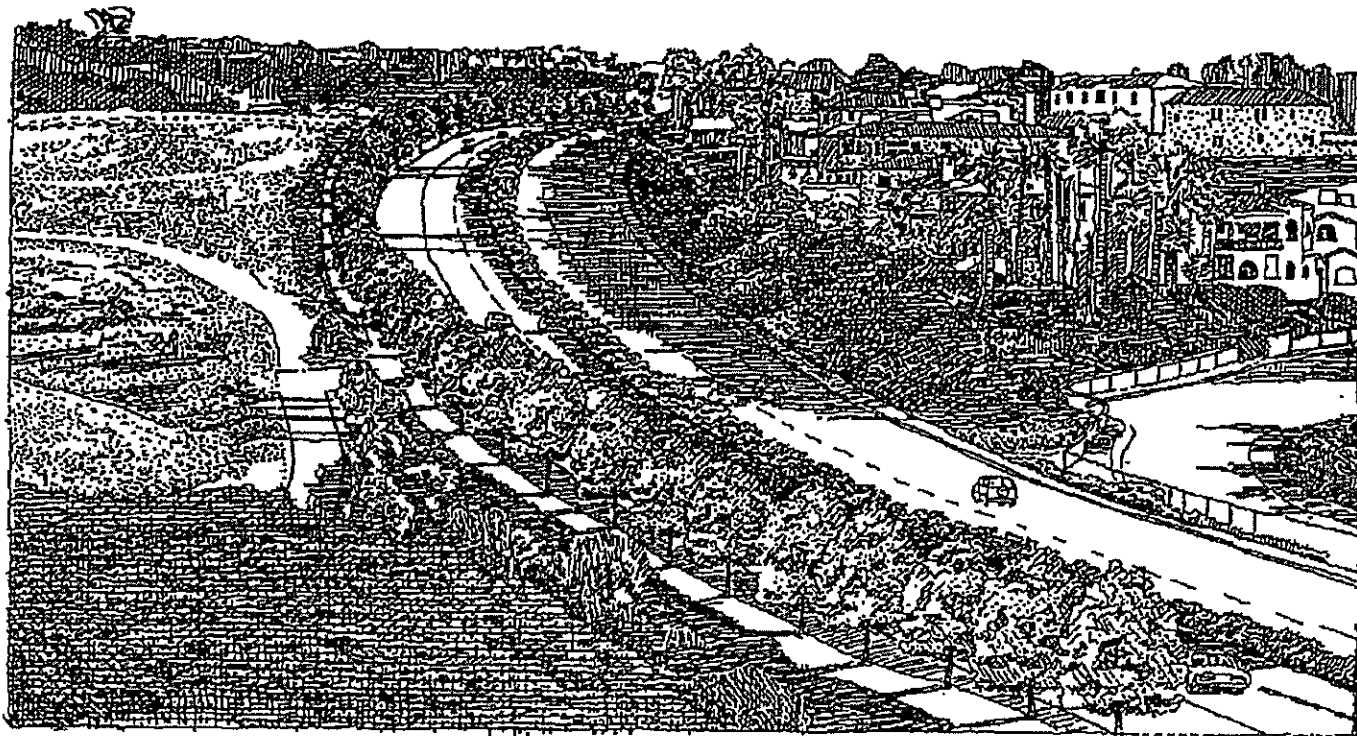

Illustrative view. Pacific Coast Highway at Monarch Beach.

The Urban Design, Conservation and Open Space, and Circulation Elements of the *Dana Point General Plan* identify adopted City policies for the preservation of public views and public view corridors. Public views are an important part of Dana Point's environmental setting and character. It is the policy of the City to protect public views when reviewing new development proposals and public improvement plans. Public views from streets and public spaces should be preserved, and new views opened where opportunities exist.

See comment 38

The Designated "Scenic Highways" of the City are listed below.

- Coast Highway
- Pacific Coast Highway
- Del Obispo Street
- Del Prado
- Dana Point Harbor Drive
- Cove Road
- Street of the Golden Lantern
- Crown Valley Parkway
- Stonehill Drive
- Selva Road
- Doheny Park Road
- Camino de Estrella
- Niguel Road
- Camino Capistrano

A complete listing of the City's existing and proposed public parks is given in the Open Space Element of the *Dana Point General Plan*.

See comment 39

1. View Analysis See comment 40

The primary concern of this section is the protection of ocean and coastal views from the public areas, rather than coastal views from private residences where no public vistas are involved. Public views are an important and valuable community resource. Proposed private development and public improvement projects that have potential to impact public views of the coastline, ocean or inland mountains should carefully document existing views and potential alterations of views that would result from the project.

- Prepare a series of photographs, as necessary, to record existing public views that may be affected by the project. These should be taken from public view points (Scenic Highway, public street or public open space). In most instances, the views selected should be within 500 feet of the site. In some cases, however, the views affected may be from more distant points in the City.
- Prepare perspective sketches or other acceptable drawings that illustrate the changes to the view that would result from the project. Include grading, buildings, accessory structures, and all other features that may affect the view. It is suggested that the illustrations be either overlays on the photographs or side-by-side comparisons of "before" (photograph) and "after" (drawing of the same view, with the project inserted).
- Summarize the view impacts in a brief written statement.
- The City may require more extensive view analysis and documentation in large development projects, or in special cases where critical public views may be affected by private or public improvements. See comment 41

2. Design Guidelines

- When public views are affected by a proposed development project, careful site planning, architecture and landscape design should be used to minimize interference with views.
- Site organization should place buildings, parking areas, signs and other features in locations that preserve existing views. For example, this may require a building setback greater than that required by the Zoning Ordinance, or location of the building in a particular part of the site. The City may consider Zoning Variances to required setbacks and other development standards in order to provide design flexibility in cases where public views are to be preserved.

- Building forms should be carefully designed to minimize disruption of public views. For example, it is often possible to "step back" the upper story of a building to enlarge the visual field of a view corridor, or to lower building elements in locations within a view corridor.

See comment 42

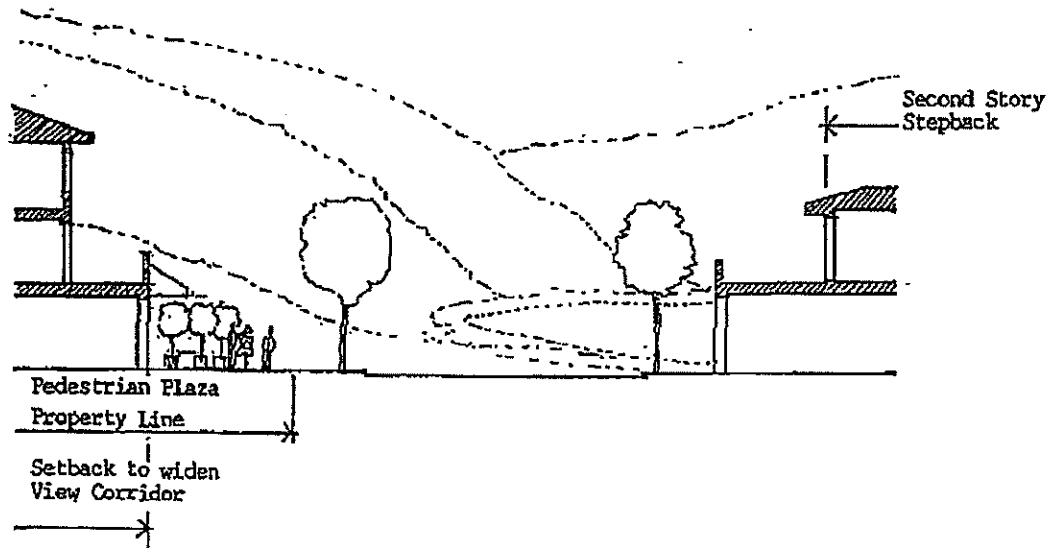

- Roof forms and story heights should be adjusted to preserve public views. Although sloped roof forms are encouraged throughout the City, a flat roof may be desirable in a case where a public view can be preserved through a lower roof height.
- Landscape elements should be carefully selected to minimize disruption of public views. Consider the height, form and mass of all plant materials at maturity. Tree topping is a poor solution to improper planting choices.

See comment 43

## Appendix B. Design Checklist

The following Checklist provides an overview of key Design Guidelines and is intended as a quick reference. It highlights the Guidelines, but does not list all Guidelines which may be applicable to a project. The Checklist is best used as a tool to check a project design or submittal, but is not intended as a substitute for the full text of this document.

Section	Guideline	Page Reference
<b>II.A.</b>	<b>Site Design</b>	
	___ 1. Provide analysis of existing conditions on and adjacent to the site.	4
	___ 2. Develop compatible relationships to buildings and open spaces on adjacent properties.	5
	___ 3. Provide a clear circulation pattern for pedestrians, autos, and service vehicles.	6
	___ 4. Site plan and planting design should consider influences of climate.	6
<b>II.B.</b>	<b>Relationship to Neighboring Development</b>	
	___ 1. Establish circulation linkages between adjacent commercial projects.	8
	___ 2. Provide complementary building form and massing relationships with neighboring buildings.	8
<b>II.C.</b>	<b>Architectural Character</b>	
	___ 1. Provide pedestrian orientation, promote pedestrian activity and create outdoor spaces for pedestrian enjoyment.	9
	___ 2. Divide building masses into smaller parts to reduce bulk and improve building scale.	9
	___ 3. Terrace back the upper story of all buildings over two stories.	9
	___ 4. Provide sloped roof forms.	11
<b>II.D.</b>	<b>Landscape Character</b>	
	___ 1. Emphasize drought tolerance and low water use in all plant selection.	14
	___ 2. Provide street trees in all new projects and follow the street tree selection guide in Appendix D.	14
	___ 3. Provide defined courtyards and other landscaped pedestrian spaces.	15
	___ 4. Avoid large turfed lawn areas that require high water use.	15
	___ 5. Use reclaimed water when possible.	15

Section	Guideline	Page Reference
<b>II.E.</b>	<b>Historic Preservation</b>	
	__ 1. Review the Secretary of the Interior's <i>Standards for Rehabilitation and Guidelines for Rehabilitating Historic Buildings</i> when dealing with a Designated Historic Site.	16
	__ 2. Design compatible relationships with existing historic resources.	16
<b>II.F.</b>	<b>Parking and Loading Facilities</b>	
	__ 1. Minimize the number of driveway openings on public streets.	19
	__ 2. Organize parking lots into smaller parking courts with clear, attractive pedestrian pathways to buildings.	19
	__ 3. Soften off-street parking lots from street view with perimeter planting or a solid wall.	19
	__ 4. Provide internal tree canopies in parking lots.	21
	__ 5. Common parking areas are encouraged in commercial districts.	24
	__ 6. Underground and decked parking is encouraged in the Town Center and other densely-built areas of the city.	24
<b>II.G.</b>	<b>Building Equipment and Services</b>	
	__ 1. Locate and design building services to minimize visual impact on public streets and neighboring properties.	25
	__ 2. Locate service access and trash collection on alleys where alleys exist.	25
	__ 3. Minimize roof-mounted mechanical equipment.	25
<b>III.A.</b>	<b>Residential Development (Attached Single Family, Duplex and Multi-Family)</b>	
	__ 1. Orient dwellings to the street, interior courtyards or garden spaces.	28
	__ 2. Interior corridors are discouraged as primary entrances to dwellings.	29
	__ 3. Provide a fully-landscaped yard in all street-facing setback areas.	29
	__ 4. Integrate new streets and sidewalks with neighboring properties.	30
	__ 5. Provide usable open space for each dwelling.	31



Section	Guideline	Page Reference
<b>III.A.</b>	<b>Residential Development (Attached Single Family, Duplex and Multi-Family) (Continued)</b>	
	__ 6. Divide the bulk and mass of residential buildings into smaller parts.	32
	__ 7. Create street frontages with architectural and landscape interest.	32
	__ 8. Minimize the number of garage doors facing public streets.	33
	__ 9. Provide "parking courts" and "parking drives." Minimize large parking lots.	33
<b>III.B.</b>	<b>Commercial, Mixed-Use and Office Development</b>	
	__ 1. Orient principal building elevations to public streets and sidewalks.	35
	__ 2. Locate buildings near the front property line and place parking to the rear and side of the building.	36
	__ 3. Provide active building frontages with pedestrian interest.	36
	__ 4. In most locations, separate the sidewalk from the curb with a parkway. Provide street trees and other plantings in the parkway strip.	37
<b>III.C.</b>	<b>Industrial and Business Park Development</b>	
	__ 1. Provide a 20 foot Landscaped Street Edge along public streets.	40
	__ 2. Screen storage yards and service areas from off-site views.	40
	__ 3. Follow special Architectural Guidelines for industrial and business park development.	41
<b>IV.A.</b>	<b>Multi-Building Hillside Residential Development</b>	
	__ 1. Use varied materials, colors, and forms to achieve visible distinctions between buildings.	43
	__ 2. Locate buildings on different levels to achieve height variation.	43
	__ 3. Retain significant trees and other vegetation.	44
	__ 4. Minimize grading impacts in the layout of streets and lots.	44
	__ 5. Create slopes that approximate natural grades.	44
	__ 6. Design terracing with small incremental steps.	
	__ 7. Select plant materials for erosion control, fire protection, drought tolerance, and visual criteria.	46
	__ 8. Provide transitional planting zones in fire hazard areas.	48

Section	Guideline	Page Reference
<b>IV.B.</b>	<b>Scenic Highways and Public View Corridors</b>	
	<ul style="list-style-type: none"> <li>— 1. Projects that impact public views must provide a View Analysis (see Page 50).</li> <li>— 2. Site planning and building design should preserve existing public views. Building setbacks and other development standards may be modified, if necessary, to preserve public views.</li> </ul>	50
		50
	<b>Guidelines for Special Districts:</b>	
<b>V.A.</b>	<b>The Dana Point Town Center</b>	
	<ul style="list-style-type: none"> <li>— 1. Design sites and buildings to emphasize a pedestrian orientation and create a high-quality pedestrian district.                             <ul style="list-style-type: none"> <li>• Building frontages oriented to the sidewalk.</li> <li>• Street trees, street furniture and pedestrian-oriented lighting.</li> <li>• High-quality pedestrian open spaces.</li> <li>• Active building frontages.</li> <li>• Parking located to the rear of buildings with alley access where alleys exist.</li> <li>• Small-scale building frontages to achieve a “village” atmosphere.</li> </ul> </li> <li>— 2. Provide a 12-15 foot sidewalk space with “buffer” area between the walking surface and street. Plant street trees in the buffer area.</li> </ul>	54
		56
<b>V.B.</b>	<b>Doheny Village</b>	
	<ul style="list-style-type: none"> <li>— 1. Doheny Park Road                             <ul style="list-style-type: none"> <li>• Locate buildings on or near the front property line to create pedestrian interest along the sidewalk.</li> <li>• Locate parking lots to the rear or interior side of buildings.</li> <li>• Parking lots located to the sides of buildings should limit their dimension parallel to the street to one double parking bay (65 feet). Setback the parking lot at least 10 feet from the sidewalk.</li> </ul> </li> </ul>	62
		63
		63

Section	Guideline	Page Reference
V.B.	Doheny Village (Continued)	
	<ul style="list-style-type: none"> <li>• Provide a continuous sidewalk from the front property line to the curb. Separate the sidewalk from the curb with a buffer area of street trees, other plantings, and street furniture.</li> </ul>	63
	<ul style="list-style-type: none"> <li>2. The Coast Highway (between Doheny Park Road and Palisade Drive)                             <ul style="list-style-type: none"> <li>• Provide a landscaped setback between the sidewalk and building frontages.</li> <li>• Divide building masses into smaller-scale components.</li> </ul> </li> </ul>	63 64
V.C.	The Pacific Coast Highway (from the Dana Point Town Center to Doheny Village)	
	<ul style="list-style-type: none"> <li>1. Locate buildings on or near the front property line to create pedestrian interest along the sidewalk.</li> </ul>	66
	<ul style="list-style-type: none"> <li>2. Locate parking lots to the rear or interior side of the building.</li> </ul>	66
	<ul style="list-style-type: none"> <li>3. Minimize the number of driveway openings on the Pacific Coast Highway. Developments are limited to one driveway opening on the highway.</li> </ul>	66
	<ul style="list-style-type: none"> <li>4. Shared driveways and parking facilities are encouraged.</li> </ul>	66
	<ul style="list-style-type: none"> <li>5. Provide street-facing pedestrian entrances.</li> </ul>	66
	<ul style="list-style-type: none"> <li>6. Provide a public sidewalk and street trees.</li> </ul>	66
V.D.	Lantern Village	
	<ul style="list-style-type: none"> <li>1. Orient buildings and individual dwellings to the street or an interior courtyard.</li> </ul>	68
	<ul style="list-style-type: none"> <li>2. Locate parking lots and garages to the rear or interior side of the property.</li> </ul>	69
	<ul style="list-style-type: none"> <li>3. Fully-landscape all required Front, Side and Rear Setback spaces.</li> </ul>	69
	<ul style="list-style-type: none"> <li>4. Provide 1 and 2 story buildings.</li> </ul>	69
	<ul style="list-style-type: none"> <li>5. Articulate buildings with bays, balconies, recesses, sloped roofs, detail, and interesting roof lines to achieve architectural interest.</li> </ul>	69

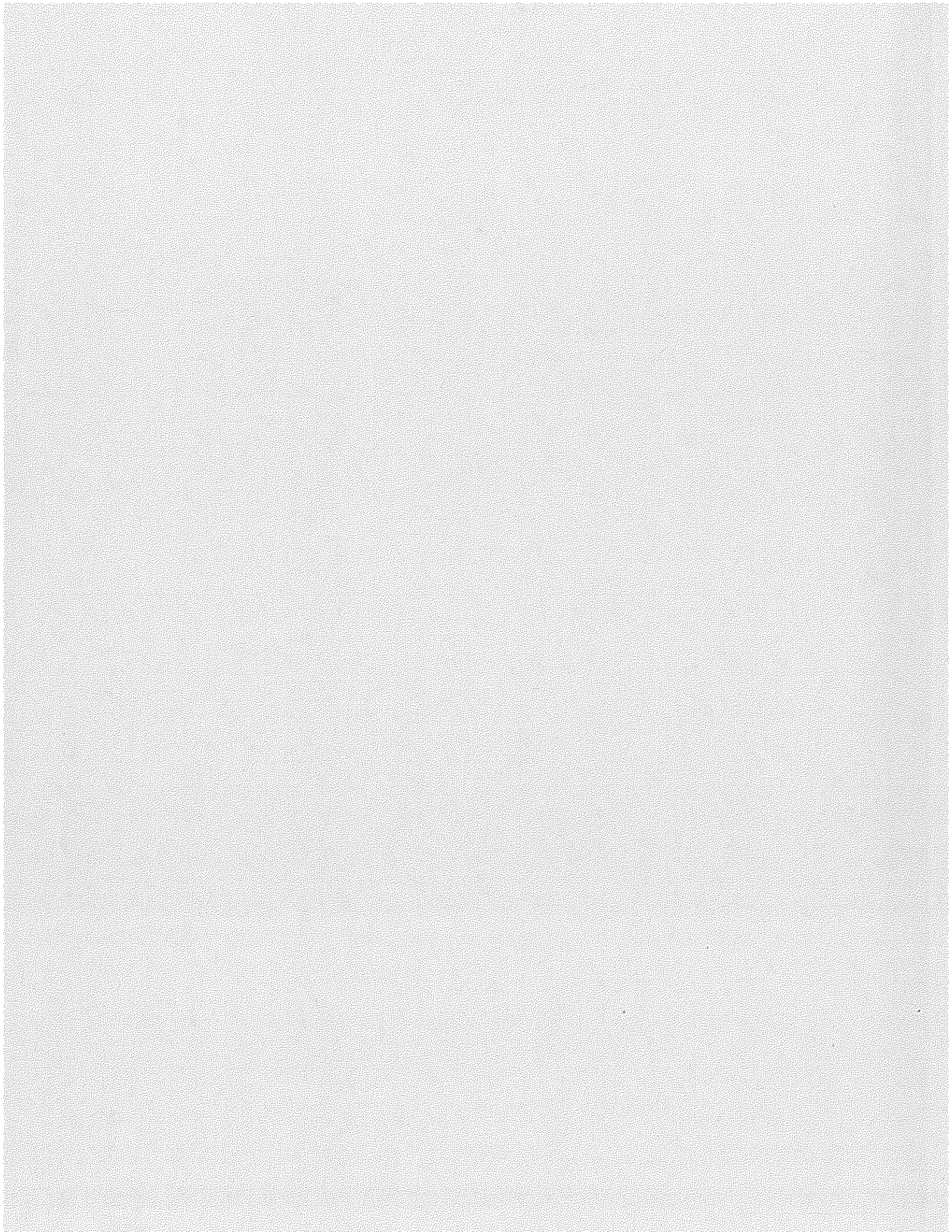

CITY OF DANA POINT  
LAND USE ELEMENT

COMMENTS

1. Suitable development of Monarch Beach and resident-serving protection are of paramount importance.
2. A developer must consider his impacts on the entire community, not just maximization of tax-exempt revenue on the overbuilt site.
3. To date, the developer and the city have failed to consider the impact of this project on surrounding land uses or parks, trails, wildlife habitat, bluffs, the Salt Creek Scenic/View Corridor and Monarch Beach.
4. By design, the project intrudes into existing residential communities and, most significantly, the communities to the south and the line-of-sight communities to the east. Because of the Salt Creek canyon, there is no buffer between the project and the communities 700 feet downwind to the east.
5. Monarch Beach does not have the infrastructure in place to support this ten-year project. Where will the earth-moving trucks be staged? It appears that the staging area is facing the residential communities to the east. Where will the workers and buses park?
6. A ten-year build out will adversely impact some of the nearby residents for the rest of their lives.
7. The developer has stated that it needs the ten-year build out because it does not have the funding in place. With the number of fellow wealthy Baptist communities in severe financial distress, we question how the project will be completed. The developers scheduled construction of the multi-story parking facility at the end of ten years because they cannot afford it. In the absence of completion bond for the entire project it is improbable that the non-revenue producing parking garage will ever be built. Where will the community and Crown Valley be with the revenue-producing parts of the project complete, but the necessary parking facilities abandoned. Drive by the Headlands commercial center on Pacific Coast Highway that has been abandoned midway through development.
8. The developer's plan is a classic example of overuse and overcrowding in the wrong location.

9. Particularly during the ten-year build out, air pollution will be unnecessarily and catastrophically increased, especially to the residents to the east, as a result of placing the staging area on the east side of the project.
10. This private development serves no community purpose justifying the super size. This overcrowded project is devoid of design quality to merit the proposed increase in intensity.
11. Will the facility provide public parking and access to the Salt Creek Regional Park and beach?
12. Every aspect of this project violates each element mandated here. Protection of bluffs is integral to Dana Point and Monarch Beach growth, planning and management.
13. The developer ignores the bluff and then destroys it by cutting and backfilling.
14. Bluffs consume almost two acres of the nominal five-acre parcel (Crown Valley Parkway consumes another acre), reducing the actual area available for development to about three acres.
15. Further development should be moved back from the bluff edge, not on and over it.
16. The developers have given no consideration to the environmental impacts on the expansion of their facility.
17. The development is not consistent with the mandates regarding the Salt Creek Scenic Corridor.
18. The project abuts the Salt Creek Regional Park.
19. This project denigrates the character of the community. The huge retaining wall that is to be build on the bluff slope is not a community enhancement and impairs the ocean view from Camino del Avion, one of the primary viewpoints from the Salt Creek Scenic Corridor. Unfortunately, the drawings of the project are grossly out of scale and therefore fail to show the impact of the project.
20. The bluff construction, cutting and backfilling desecrate the cohesive open space of Monarch Beach.
21. This project will desecrate the dramatic public view corridor at the heart of Monarch

Beach.

22. This project destroys rather than protects natural resources and probably eradicates an endangered species, the California gnatcatcher.

23. The Monarch Beach public view corridors will be destroyed by erecting a large retaining wall 25 to 30 feet high on the slope and filling it with dirt. Please note that the submitted drawings of the project are not to scale.

24. The developers fail to preserve adequate public space.

25. The scale of the development is incompatible with existing areas. The drawings and model for this project are dramatically out of scale to give the impression that they fit unobtrusively into the landscape. A visit to our residence in Corniche Sur Mer and to the Camino del Avion bridge over the Salt Creek Trail gives one the full impact of the intrusion of this project into the landscape.

26. This project will go forward at the expense of environmentally sensitive habitat, public parks and trails, and other public areas.

27. The policies of the Monarch Beach Resort Specific Plan extend to the entire Monarch Beach community, including this project.

28. The public aspects, particularly in the case of this project, parking, erosion, and bluff protection must occur first, not when funding is available at some indefinite time in the future.

29. The proposed project will adversely impact existing public trails and recreational facilities.

30. This project will not preserve, maintain or enhance environmentally sensitive habitat along Salt Creek.

31. The residents of the area daily engage in use of the of the trail, golf course and other outdoor activities that will be drastically curtailed by this project. The developers are also going to provide services to the area that are already available within the area.

32. Contrary to the publicly-stated directive of the City Manager, the Baptist Church does not have the God-given right to do whatever it wants to the site.

33. The developer and its supporters ignore environmental constraints, bluffs, ridges, steep slopes greater than 2:1, known seismic and landslide areas, groundwater, drainage, storm run-off, the gnatcatcher wildlife preservation area, Salt Creek, the Salt Creek Trail, the Salt Creek Scenic Corridor, the Salt Creek Regional Park, the Coastal Commission, the Monarch Beach Golf Links, the Salt Creek Water Treatment Facility and Salt Creek Beach. They also ignore their line-of-sight neighbors.

34. When all of the facilities are included and the buildable land used as the denominator, the state-wide standard for FAR is grossly exceeded.

35. This project offers neither exceptional design nor important public amenities or benefits. This is a non-tax-paying developer engaged in a commercial, revenue-producing venture.

36. The named communities all include parking in their FAR calculations. This project, encircled by residential and recreational elements, significantly exceeds the FAR intensities allowed in all other Orange County (and California) communities.

37. Applying the net acre calculation with due consideration to the actual acreage of Crown Valley Parkway and the bluff slope yields a site about half the nominal site size claimed by the developer. The project, however measured, is simply too big for the site. They start with a nominal six acres. One to 1 1/2 acres have already been dedicated to and consumed by Crown Valley Parkway on the western side of the site. An additional two acres of the site on the eastern side are not buildable because they are over an unstable bluff with a greater than 2:1 slope. This results in a net acreage of buildable land of three actual acres reduced by another half acre after application of the net acre calculation or net 2.5 acres. On that small parcel the developers propose building two to three acres of facilities and three to five acres of parking garages.

As part of the EIR analysis, a complete survey of the site needs to be completed showing the dimensions of the Crown Valley Parkway dedication and the eastern strip on the 2:1 slope and the bluff. That survey will mathematically demonstrate that the site lacks necessary space for the development.

37A. The City recently disclosed that the County granted an R-1 Variance for the church and later a small school. The City has no records of any formal action changing the zoning of the site – no notice to neighbors, no consent or hearings. Therefore, the project must be treated as a project in an R-1 residential area.

38. The facility is too big for the site. The site should be 10 to 30 acres for the uses they intend to make. With 30 acres on a different site they could provide adequate parking,



drainage, landscaping, slope protection and bluff protection.

39. The proposed uses of the facilities extend significantly beyond the limited community facility designation.

40. The Monarch Beach Specific Plan area for the resort, as part of a comprehensive community plan, raises issues and concerns applicable to abutting properties within the Salt Creek Basin, including the project and the impacted residential areas to the north, west, east and south.

# INTRODUCTION TO THE LAND USE ELEMENT

---

The Land Use Element is a guide to the allocation of land use in the City and has major impacts on key issues and subject areas examined in the other Elements of the Plan. For example, all future land use within the City described in this Element will affect the transportation system discussed in the Circulation Element, residential development affects housing policies and programs contained in the Housing Element, and identified recreational or open space lands represent the application of Conservation/Open Space Element policy planning. Land use policy will also affect numerous issues in the remaining Plan Elements, including those concerned with Economic Development, Urban Design, Public Facilities and Growth Management, Public Safety, and Noise.

The Land Use Policy Diagram which describes future planned land uses within the City is a primary feature of the Element. The Land Use Policy Diagram is included in this Element and a larger version is included in the pocket of the General Plan document binder. The land use designations depicted on the Diagram are described in the narrative portion of the Land Use Element.

## PURPOSE OF THE LAND USE ELEMENT

---

The City of Dana Point represents the unification of three distinct pre-incorporation communities -- Dana Point, Monarch Beach and Capistrano Beach. These coastal communities developed together, before incorporation, through the efforts of local community planning groups with guidance provided by the County of Orange. That history of strong local involvement in the planning process, and the existence of common goals and aspirations led to the incorporation of the City of Dana Point in 1989. To maintain and improve the quality of Dana Point, the City will strive to achieve Land Use desires through the implementation of the policies contained in this Element. The goals include:

- Establishment of a balanced, functional mixture of different types of Land Use that are consistent with the City's long-range goals and values;

- Quality new development or revitalization of existing development within the City and removal of constraints that prevent these desirable changes;
- Preservation of developed and undeveloped portions of the City which have cultural, social and natural resource value to the City and its citizens;
- Financially sound investment of public and private funds that effectively supports both desirable change and preservation within the City; and
- Reduction of loss of life, injury and property damage that might occur as a result of natural hazards, such as flooding, seismic activity, soils erosion and storm waves, and man-made hazards, such as unsound construction, poor traffic patterns and roadway conditions, and incompatibility among different land uses.

The Land Use Element promotes the achievement of these goals by establishing clear, logical patterns and standards for future land use. The Element does so through the use of narrative text, tables, diagrams and mapping, and its single most important feature is the Land Use Policy Diagram. This diagram, a copy of which is contained in the Element and in the pocket of the General Plan document binder, indicates the location, density and intensity of future development for all land uses city-wide. Finally, the goals and policies contained in this Element establish a constitutional framework for future land use planning and decision making in the City.

## **SCOPE AND CONTENT OF THE ELEMENT**

---

This Element presents the City's goals and policies regarding land use for the long-term growth, development and revitalization of the City. The Land Use Element contains text describing land use goals and policies, land use descriptions, a Policy Diagram and a statistical summary of the land use distribution illustrated on the Policy Diagram.

The Land Use/Local Coastal Element Technical Report, prepared prior to preparation of the Land Use Element, is a supporting background document which contains quantitative information about the distribution of land use in Dana Point.

---

## LAND USE ELEMENT GOALS AND POLICIES

---

The goals and policies contained in this element provide guidance for development of vacant land, revitalization of existing development, and preservation of the many stable and desirable areas within the City. The goals and policies of this element are aimed at:

- °Achieving a balanced mixture of residential, commercial, industrial, and other land uses;
- °Achieving compatibility and enhancement among the various land use types;
- °Directing growth to maintain and improve the quality of life;
- °Preserving natural environmental resources;
- °Providing for suitable development of the Headlands;
- °Achieving enhanced development of the Town Center as a primary business district;
- °Achieving revitalization of the Doheny Village as a primary business district;
- °Providing for suitable development of Monarch Beach; See comment 1
- °Protecting resident-serving land uses; and
- °Implementing state coastal resources planning and management policies.

As described earlier in this element, identification of those coastal resources planning and management policies within the Land Use Element, which are part of the City's Local Coastal Program, is provided by parenthetical references to the applicable sections of the California Coastal Act.

and provision of, the service would not induce new development inconsistent with the City of Dana Point certified local coastal program. (Coastal Act/30254)

## **COMPATIBILITY AND ENHANCEMENT AMONG LAND USES**

As the City develops, new land uses replace existing ones and the characteristics of individual land uses which distinguish them from one another can also be described as differences which cause them to be incompatible when they occur close together. For example, the traffic, night lighting, noise, and odors associated with an otherwise successful commercial area may be perceived as nuisances for nearby residents. An understanding of impacts which occur when different types of land use develop close to one another leads to proper planning and positive impacts on surrounding land uses. The use of horizontal separation, vertical separation of buildings and uses, landscaping, walls, and proper orientation of buildings, lighting, and street access can avoid or minimize land conflicts and impacts, and enhance the overall living environment.

See comment 2

**GOAL 2: Achieve compatibility and enhance relationships among land uses in the community.**

**Policy 2.1:** Consider the impacts on surrounding land uses and infrastructure when reviewing proposals for new development. (Coastal Act/30250) See comment 3

**Policy 2.2:** Visitor serving commercial areas shall not intrude into existing residential communities. (Coastal Act/30250)  
See comment 4

**Policy 2.3:** Develop regulatory mechanisms to mitigate land use conflicts. The portions of the General Plan effectively certified by the Coastal Commission as the Land Use Plan shall take precedence over all other General Plan elements in the area of the City within the Coastal Zone.

**Policy 2.4:** Encourage the use of shared parking facilities, such as through parking districts or other mechanisms, in a manner that maintains and, where feasible, improves public access to the coast. (Coastal Act/30212.5/30252)

**Policy 2.5:** Facilities serving the commercial fishing and recreational boating industries shall be protected and, where feasible, upgraded. Proposed recreational boating facilities shall, where feasible, be designed and located in such a fashion as not to interfere with the needs of the commercial fishing industry. (Coastal Act/30234)

**Policy 2.6:** Increased recreational boating use of coastal waters shall be encouraged, consistent with other provisions of the certified local coastal program. (Coastal Act/30224)

**Policy 2.7:** Coastal-dependent developments, as defined in Chapter 9.75 of the Zoning Code, shall have priority over other developments on or near the shoreline. Except as provided for in Conservation and Open Space Element Policy 3.6, coastal-dependent developments shall not be sited in a wetland. Coastal-related developments should be accommodated within the closest feasible proximity to the coastal-dependent uses they support. (Coastal Act/30255)

**Policy 2.8:** Coastal water areas suited for water-oriented recreation activities shall be protected for such uses. (Coastal Act/30220)

**Policy 2.9:** Oceanfront land suitable for recreational use shall be protected for recreational use and development unless present and foreseeable future demand for public or commercial recreational activities that could be accommodated on the property is already adequately provided for in the area. (Coastal Act/30221)

**Policy 2:10:** The use of private lands suitable for visitor-serving commercial recreational facilities designed to enhance public opportunities for coastal recreation shall have priority over private residential, general industrial, or general commercial development, but not over agriculture or coastal-dependent industry. (Coastal Act/30222)

**Policy 2:11:** The location and amount of new development should maintain and enhance public access to the coast by assuring that the recreational needs of new residents will not overload nearby coastal recreation areas through the correlation of the amount of development with local park acquisition and development plans with the provision of on-site recreational facilities to serve the new development. (Coastal Act/30252(6))

**Policy 2:12:** Oceanfront land that is suitable for coastal dependent aquaculture shall be protected for that use, and proposals for aquaculture facilities located on those sites shall be given priority, except over other coastal dependent developments or uses. (Coastal Act/30222.5)

## **DIRECTING GROWTH TO MAINTAIN AND IMPROVE QUALITY OF LIFE**

---

As the City matures, additional demands will be placed on public services and infrastructure (e.g., police, fire and recreation, and streets, water lines, sewer lines, power lines, and others). The infrastructure system serving Dana Point includes major components or "back bone systems" which can provide the capacity to accommodate projected growth. The secondary components, connecting development with the major components of the infrastructure system, must be extended to support new development and replacement of aging portions of the system needs to occur in the future to maintain the present quality of services provided. Continued demand for these public

services and facilities requires adequate planning for the financing of future improvements to ensure that the quality of City life is maintained or improved in the future. See comment 5

**GOAL 3: Direct growth of the community so as to maintain and improve the quality of life.** See comment 6

**Policy 3.1:** Require new development to contribute its share of the cost of providing necessary public services and facilities through equitable development fees and exactions. (Coastal Act/30250)

**Policy 3.2:** Coordinate Dana Point's land use and growth policies with the County and other communities in the region to strengthen and promote interjurisdictional communication and cooperation.

**Policy 3.3:** Priority should be given to those projects that provide for coastal recreational opportunities for the public. Lower cost visitor and recreational facilities shall be protected, encouraged, and, where feasible, provided. Upland areas necessary to support coastal recreational uses shall be reserved for such uses, where feasible. (Coastal Act/30213, 30222, 30223)

**Policy 3.4:** Examine the short term and long term fiscal effects of development and revitalization decisions. See comment 7

**Policy 3.5:** Public facilities including parking areas or facilities shall, wherever appropriate and feasible, be distributed throughout the coastal zone area to mitigate against the impacts, social and otherwise, of overcrowding and overuse by the public of any single area. (Coastal Act/30212.5) See comment 8

**Policy 3.6:** Encourage patterns of development necessary to minimize air pollution and vehicle miles traveled. (Coastal Act/30250) See comment 9

**Policy 3.7:** Encourage safe and convenient bicycle and pedestrian access throughout the community. (Coastal Act/30210-212.5, 30250, 30252)

**Policy 3.8:** Allow increases in intensity up to the maximum floor area ratio identified in the Land Use Element only where development projects demonstrate exceptional design quality,



important public amenities or public benefits, or other factors that promote important goals and policies of the General Plan.

See comment 10

**Policy 3.9:** Designate the right-of-way for Alipaz Street for Open Space use if Alipaz Street is removed from the Master Plan of Arterial Highways in the future.

**Policy 3.10:** Consider designating vacated street rights-of-way for Open Space use. Any public rights-of-way which lead to navigable waters shall not be vacated, and may be used for public recreation/open space or public pedestrian purposes if not needed for vehicular traffic. (Coastal Act/30210-212, 30213)

**Policy 3.11:** Development shall not interfere with the public's right of access to the sea where acquired through use or legislative authorization, including, but not limited to, the use of dry sand and rocky coastal beaches to the first line of terrestrial vegetation. (Coastal Act/30211)

**Policy 3.12:** Public access from the nearest public roadway to the shoreline and along the coast shall be provided in new development projects except where it is inconsistent with public safety, military security needs, or the protection of fragile coastal resources, or where adequate access exists nearby, including access as identified on Figures UD-2 and COS-4. (Coastal Act/30212) See comment 11

## **PRESERVATION OF NATURAL RESOURCES**

---

Portions of the City consist of fragile coastal beaches and bluffs, hillsides, and canyons which are sensitive to changes associated with land development. These fragile areas provide an important sense of place and openness. Preservation of such areas provides a physical buffer protecting persons and improvements from natural and man-made safety hazards. These areas also present opportunities for passive recreation, such as trails for bicycling and hiking, which result in only minimal disruption to sensitive lands. See comment 12

In the General Plan, bluff demarcation is drawn based on a mean estimation projected across all parcels impacted by coastal bluff areas. The specific location of the bluff line, as it is applied to an individual parcel, will be established consistent with existing policies and criteria in effect when building plans are submitted.

See comment 13

**GOAL 4: Encourage the preservation of the natural environmental resources of the City of Dana Point.**

**Policy 4.1:** Exclude areas designated as Open Space and areas containing wetlands, beaches, and bluffs from the calculation of net acreage available for determining development intensity or density potential. See comment 14

**Policy 4.2:** Consider the constraints of natural and man-made hazards in determining the location, type and intensities of new development. (Coastal Act/30240, 30253) See comment 15

**Policy 4.3:** Public access, which shall be conspicuously posted, and public recreational opportunities, shall be provided to the maximum extent feasible for all the people to the coastal zone area and shoreline consistent with public safety needs and the need to protect public rights, rights of private property owners, and natural resource areas from overuse. (Coastal Act/30210)

**Policy 4.4:** Preserve, maintain and, where feasible, enhance and restore marine resource areas and coastal waters. Special protection shall be given to areas and species of special biological or economic significance. (Coastal Act/30230)

**Policy 4.5:** Consider the environmental impacts of development decisions. (Coastal Act/30240, 30241, 30242, 30243, 30244)

See comment 16

LAND USE ELEMENT

**Policy 4.6:** Ensure land uses within designated and proposed scenic corridors are compatible with scenic enhancement and preservation. (Coastal Act/30251) See comment 17

**Policy 4.7:** Coordinate with appropriate Park, Recreation and Harbor Agencies to enhance Open Space trails and bike paths. (Coastal Act/30210-212.5) See comment 18

**Policy 4.8:** Encourage the reasonable regulation of signs to preserve the character of the community. (Coastal Act/30251)  
See comment 19

**Policy 4.9:** Encourage the preservation of significant natural areas as cohesive open space. See comment 20

**Policy 4.10:** Regulate the construction of non-recreational uses on coastal stretches with high predicted storm wave run-up to minimize risk of life and property damage. (Coastal Act/30253)

## **DEVELOPMENT OF THE HEADLANDS**

---

The Headlands is one of the most significant land forms and undeveloped properties in the City. The Headlands offers important opportunities for future development and, at the same time, includes sensitive coastal bluffs which represent substantial constraints to development. The property provides spectacular views of the Dana Point Harbor and the coastline to its north and south. Thus the Headlands offers a distinct opportunity to provide a continuous open space corridor along the coast with views and public access to the ocean, coastline and harbor. The property is large enough to accommodate a mixture of land uses that include visitor-serving commercial, residential, recreation, open space, and community facilities.

**GOAL 5: Provide for the development of the Headlands area in a manner that enhances the character of the City and encourages the protection of the natural resources of the site.**

**Policy 5.1:** Preserve the opportunity of public views from the Headlands site to the coastal areas and the harbor areas. (Coastal Act/30251)

**Policy 5.2:** Require geotechnical studies to ensure geological

**Policy 7.7:** Prepare a Specific Plan for revitalization of the Doheny Village Area. The Specific Plan should involve extensive public input.

## **DEVELOPMENT OF MONARCH BEACH**

---

The Monarch Beach area is indicative of development based on master planning efforts and high quality development standards. The Ritz Carlton Resort Hotel and an additional resort hotel site north of Pacific Coast Highway provide focal uses in a community which includes extensive outdoor activities such as golf (The Links at Monarch Beach) and coastal recreation (Salt Creek Beach Park and Dana Strand Beach). Monarch Beach has dramatic public view corridors within the coastal Salt Creek Basin. See comment 21

**GOAL 8: Provide for the development of the Monarch Beach area in a manner that enhances the character of the City and encourages the protection of the natural resources of that area. See comment 22**

**Policy 8.1:** Preserve the opportunity of public view corridors from Monarch Beach area to the coast. (Coastal Act/30251)  
See comment 23

**Policy 8.2:** Assure that adequate public recreational areas and public open space are provided and maintained by the developer as part of a new development. (Coastal Act/30210, 30213, 30240, 30251) See comment 24

**Policy 8.3:** Assure that the height and scale of new development is compatible with the existing areas. See comment 25

**Policy 8.4:** Promote the development of a mixture of residential, visitor-serving, and open space land uses; with an ultimate residential density cap of 238 dwellings, which shall not be exceeded.

**Policy 8.5:** Require that the pedestrian and bike trail systems be extended throughout Monarch Beach and connected with the existing and proposed City wide trail system.

**Policy 8.6:** Maximize the provision of public trail and transit loop systems within the Monarch Beach area. The systems shall

include access to and along the shoreline and to the visitor-serving and public places within Monarch Beach. (Coastal Act/30210)

**Policy 8.7:** Encourage public access, visitor-serving and residential land uses with a strong public component which allows the public to enjoy such visitor-serving commercial facilities.

**Policy 8.8:** Salt Creek Beach Park shall be a public park primarily oriented to passive recreational use, with limited active recreational and educational uses which are temporary and non-commercial in nature. (Coastal Act/30210, 30214).

**Policy 8.9:** Avoid expansion of the golf course or any other land use that occurs at the expense of environmentally sensitive habitat, public park or public areas. (Coastal Act/30210, 30213, 30240) See comment 26

**Policy 8.10:** Encourage the immediate development of visitor serving resort facilities and land uses of a world class stature to be achieved within five years from the date of adoption of the General Plan. The resort facility shall include a 400 or so key five star resort hotel. If public open space and Visitor/Recreation Commercial land uses are not physically developed and established within five years, it is the policy of the City of Dana Point to revisit other land uses within this area and to assure the provision of open space and Visitor/Recreation Commercial activities. See comment 27

**Policy 8.11:** Provide for the temporary landscaping of existing graded pads with perennial wild flowers and other vegetation to assure aesthetic enhancement of the area, reduce soil erosion, and reinforce the ultimate open space and landscaped resort character of the area.

**Policy 8.12:** Within the Monarch Beach Resort Specific Plan, establish a development phasing plan to achieve first, the primary objective of the development of the public open space, public parks, public trails, and public roads; secondly, the visitor serving resort complex; and lastly, the residential dwellings. Concurrent development may be permitted only if the primary objective is being satisfied. (Coastal Act/30213, 30222)  
See comment 28

**Policy 8.13:** The existing public trails and public recreational facilities within the Monarch Beach Resort Specific Plan area shall be preserved and maintained. Signs shall be posted at conspicuous locations within the Specific Plan area, and a manned information center established in the Monarch Beach Resort hotel, to inform the general public of the public access and public recreation opportunities available within the Specific Plan area. (Coastal Act/30210-30213, 30220-222, 30223)

See comment 29

**Policy 8.14:** Visitor-serving facilities within the Monarch Beach Resort Specific Plan area, including but not limited to the recreational time slots of the golf course and the parking lots of the hotel and golf course, shall be open to the public. (Coastal Act/30210, 30212.5, 30213)

**Policy 8.15:** Preserve, maintain, and where feasible enhance and restore, the riparian habitat, coastal sage scrub habitat, and other environmentally sensitive habitat areas along Salt Creek.

See comment 30

## **DEVELOPMENT OF CAPISTRANO BY THE SEA**

The site known as Capistrano by the Sea encompasses 24.7 acres of partially developed land, located at the top of a prominent hill overlooking San Juan Creek and the Dana Point Harbor. In addition, distant views of the valley, the coastline to the south and Saddleback Mountain are visible from some locations on the site. The site is surrounded by residential uses, predominantly single-family homes, and St. Edwards Catholic Church to the west. There is a grove of mature trees on the site, mostly eucalyptus, which creates a visual background for Doheny Village and the eastern section of the City. Onsite uses include the historic Dolph House (considered to be the City's first residence) and structures that were previously used as a psychiatric hospital and church. Due to the prominent location

and high visibility of the site, the existing mature trees and the surrounding existing residential community, there are constraints to development.

**GOAL 9: Provide for the development of Capistrano by the Sea site in a manner that enhances the character of the City and encourages the preservation of views of the site from**

### **Doheny Village.**

**Policy 9.1:** Promote the development of land uses that are compatible with the surrounding residential neighborhoods, with an ultimate residential density cap of 43 new dwellings plus the Dolph House.

**Policy 9.2:** Provide vehicular access that does not adversely impact adjoining neighborhoods or create congestion on surrounding streets.

**Policy 9.3:** Assure that the height and scale of development on the site are not in conflict with the surrounding residential uses by providing for adequate development standards relating to height limits, setbacks, and lot coverage.

**Policy 9.4:** Provide open space corridors through the site and along the southern, eastern and northern perimeter of the site that preserves a significant number of mature trees within common landscaped areas that conforms to the mitigation monitoring program prepared for GPA97-03. Create an opportunity for planting new trees to enhance the development and provide a visual backdrop similar to the existing views from Doheny Village.

**Policy 9.5:** Encourage a pedestrian circulation system that permits public access through some of the open space corridors.

**Policy 9.6:** A majority of the healthy mature trees existing at the time of this amendment, shall be preserved on the site and incorporated into the development plans within open space areas. Should it be necessary to remove any trees from the site, the trees shall be replaced in conformance with the mitigation monitoring program prepared for GPA97-03.

## **PROTECTION OF RESIDENT-SERVING LAND USES**

Dana Point citizens have a strong sense of community even though Dana Point is an attraction to many visitors. This sense of community or sharing of common goals and interests includes the desire to protect and maintain those land uses which serve the residents of the area. This involves the encouragement of

LAND USE ELEMENT

JUNE 27, 1995

resident-serving commercial activity which meets local demands for goods and services, as well as locations for offices and business uses which employ City residents. See comment 31

**GOAL 10: Protect the resident-serving land uses throughout the City.**

**Policy 10.1:** Develop regulations to protect and encourage local serving retail and office use adjacent to residentially designated areas. Promote the overlap between visitor and resident serving retail uses by encouraging retail goods and services which serve both market segments in transition areas, such as those designated "Community Commercial", located between primary visitor serving areas and areas designated for residential use as shown on the Land Use Diagram. (Coastal Act/30222)

**Policy 10.2:** Encourage a full range of resident-serving land uses throughout the City to meet the resident demand for goods and services.

**Policy 10.3:** Encourage resident-serving uses within walking distance of areas designated on the Land Use Diagram for residential use, where possible, to minimize the encroachment of resident serving uses into visitor-serving areas, to minimize the use of primary coastal access roads for non-recreational trips, and to minimize energy consumption and vehicle miles traveled by encouraging the use of public transportation. (Coastal Act/30222, 30252, 30253)

**RELATED GOALS AND POLICIES**

---

Goals and policies and the Land Use Policy Diagram identified in this element serve as the framework for other General Plan elements. A number of policies included in the Land Use Element constitute coastal resources planning and management policies that are part of the City's Local Coastal Program (LCP). Table LU-1 identifies the required components or issue areas of the LCP included in the Land Use Element.

**TABLE LU-1  
LAND USE ELEMENT  
LOCAL COASTAL PROGRAM REFERENCE MATRIX**

LAND USE ELEMENT  
JUNE 27, 1995  
(GPA95-02(c)/LCPA95-08)



---

## THE LAND USE PLAN

---

The Land Use Plan and Policy Map describe the approach to be used in implementing the Land Use Element goals and policies. The locations of future land use are presented on the Land Use Policy Diagram which is a part of this Element and is included in the pocket of the General Plan document binder. In guiding future land use, the Element focuses on three basic land use characteristics of the City:

- 1)Undeveloped parcels of land which will be the subject of most proposals for new development;
- 2)Existing consistent land use and development which, over time, will increasingly require maintenance and preservation; and
- 3)Revitalization of some land use and development where rehabilitation is necessary or conversion to other uses is desired to achieve economic or social goals of the General Plan.

---

### LAND USE POLICY CONSIDERATIONS

---

A wide range of natural and man-made environmental factors are considered in the formulation of land use policy. Areas of special environmental significance, potential safety hazards, limitations of existing infrastructure, and the nature and character of existing development all have influence on land use policy.

See comment 32

#### **Land Use Constraints and Resources**

The Public Safety Element identifies areas of Dana Point subject to such environmental constraints as flooding, landsliding, and seismic conditions. In turn, the Conservation/Open Space Element identifies areas containing important ecological or natural resources. The Circulation and Noise Elements describe roadway/transportation system capacities and areas of the City impacted by noise levels. These constraints, consisting of both natural and man-made factors, influence long-range land use planning and are discussed in detail in the Master Environmental

## **LAND USE DESIGNATIONS**

---

Land use designations indicate the type and nature of development that is allowed in a given location. While terms like "residential," "commercial" and "industrial" are generally understood, State General Plan law requires a clear and concise description of the land use categories shown on the Land Use Policy Diagram.

The Land Use Element provides for land use categories or designations listed in Table LU-3. Five of these designations are established for residential development, ranging from low-density single family to high-density multiple family development. Three commercial designations, one office, one industrial and a community facility category are included. One category of mixed use is established to offer some flexibility in providing complimentary commercial, office, and residential uses. Parkland and open space areas are combined under the recreation/open space designation. Major transportation facilities are included in a single transportation corridor category.

### **Land Use Intensity/Density**

State General Plan law requires that the Land Use Element indicate the maximum intensities/densities permitted within the City. The land use designations contained in this element and shown on the Land Use Policy Diagram are described in this way. Table LU-3 lists each of the land use designations for the City and provides a corresponding indication of maximum intensity/density of development on that parcel. Maximum allowable development on individual parcels of land is to be governed by these measures of intensity or density. The table also includes the standard or expected overall levels of development within each land use category on a City-wide basis.

These standard levels of development represent an anticipated intensity/density and are, therefore, less than the maximum allowed. For various reasons, not every parcel in the City has in the past nor will it in the future develop to the maximum allowed. See comment 34

### **TABLE LU-3 DEVELOPMENT INTENSITY/DENSITY STANDARDS**

LAND USE ELEMENT  
JUNE 27, 1995

Future development is expected to occur at the standard level of intensity/density stated in Table LU-3. Development at an intensity or density between the standard and maximum levels can occur only where projects offer exceptional design quality or important public amenities or benefits above the standards required by the City's discussed in detail in the Master Environmental Assessment for the General Plan. Urban Design Guidelines and other regulatory documents. For the residential land use designations, projects are expected to build to a density at least as high as the lowest density allowed by their respective designations. See comment 35

A number of terms are used to define the land use designations or categories described in this element. The term "intensity" refers to the degree of development based on building characteristics such as height, bulk, floor area ratio and/or percent of lot coverage.

Intensity is most often used to describe non-residential development levels, but, in a broader sense, is used to express overall levels of all development types. The overall intensity of development within the City of Dana Point is lower than the more urbanized areas of Orange County, such as Anaheim, Santa Ana, Irvine and Newport Beach. See comment 36

For most non-residential development categories (commercial, industrial, office, community facility, and recreation facilities), the measure of intensity known as "floor area ratio" (FAR) provides the most convenient method of describing development levels. Simply stated, the floor area ratio is the relationship of total gross floor area of all buildings on a lot to the total land area of that lot expressed as a ratio. For example, a 21,780 square foot building on a 43,560 square foot lot (one acre) yields an FAR of .50:1 as illustrated in Figure LU-2. The FAR describes use intensity on a lot but not the actual building height, bulk or coverage. As Figure LU-2 shows, the .50:1 FAR can yield a building of one story in height covering one half of the lot area, or a taller building which covers less of the lot and provides more open space.

For purposes of this explanation, both residential density and non-residential intensity are based on the concept of net acreage. Net acreage is assumed to be 80 percent of gross acreage on a City-wide basis and a net acre of land is assumed to equal 35,000 square feet for purposes of calculating density or intensity of

land use. See comment 37

The term "density", in a land use context, is a measure of the population or residential development capacity of the land. Density is described in terms of dwelling units per net acre (du/net ac); thus, the density of a residential development of 100 dwelling units occupying 20 net acres of land is 5.0 du/net ac. A dwelling unit is a building or a portion of a building used for human habitation and may vary considerably in size (square footage) from small apartments at 400-500 square feet to large single family homes exceeding 5,000 square feet. Along with this difference in size is a corresponding difference in the number of persons occupying a given unit (i.e., larger units usually house more persons than smaller units). For purposes of calculating population, an average number of persons per dwelling unit for all dwelling unit types and sizes is assumed as described in the notes beneath Table LU-4. Within land use designations density is often described as a range (i.e., 3.5-7 du/net ac).

Descriptions of each of the land use designations shown on the Land Use Policy Diagram are provided to delineate the general types of uses allowed and their corresponding intensities or densities. These use descriptions, types and limitations are further defined as specific uses within the Zoning Ordinance. The specific uses and development standards contained within the Zoning Ordinance and shown on the accompanying Zoning Map are consistent with the land use designations and standards contained in this Element or shown on the Land Use Policy Diagram.

### **Residential Designations**

**Residential 0-3.5:** The Residential 0-3.5 and use category provides for the development of low density detached and attached single family dwellings. This designation allows for the construction of a maximum of 3.5 single family detached units per net acre of land. Community facilities which are determined to be compatible with, and oriented toward serving the needs of low density detached and attached single family neighborhoods may also be allowed. See comment 37A

**Residential 3.5-7:** The Residential 3.5-7 land use designation provides for the development of low to medium density detached

Typical business uses include small food and drug stores, clothing stores, professional and business offices, restaurants and hardware stores, child care, specialty retail, and community facilities. Neighborhood commercial projects typically occur on less than 10 acres of land and include 25,000 to 75,000 square feet or less of building floor area. The standard intensity of development is a floor area ratio of .35:1 and the maximum intensity of development is a floor area ratio of .5:1.

**Community Commercial:** The Community Commercial designation includes retail, professional office, and service-oriented business activities which serve a community-wide area and population. Community Commercial uses include some neighborhood commercial uses, such as professional and business offices, retail and commercial services, appliance stores, sporting goods, child care, restaurants, and community facilities, along with larger scale indoor uses such as department stores, furniture and appliance outlets, theaters and entertainment uses. Community Commercial development usually occurs on 10 to 30 acres of land and includes 100,000 to 300,000 square feet of building area. The standard intensity of development is a floor area ratio of .4:1 and the maximum intensity of development is a floor area ratio of .75:1. See comment 38

**Visitor/Recreation Commercial:** The Visitor/Recreation Commercial designation includes primarily visitor-serving uses, such as restaurants, resort hotels and motels uses, commercial, recreation specialty and convenience retail goods and services, auto service businesses, open space/recreational uses, and community facilities. Other supporting uses include conference facilities and cultural uses, such as museums and theaters. The average intensity of development for hotels is a floor area ratio of .75:1 and the maximum intensity of development for hotels is a floor area ratio of 1.5:1. The standard intensity of development for other uses is a floor area ratio of .5:1 and the maximum intensity of development for other uses is a floor area ratio of 1.0:1.

### **Mixed Use Designation**

**Commercial/Residential:** The Commercial/Residential designation includes mixtures of commercial, office and residential uses in the same building, on the same parcel, or within the same area. The primary uses within this designation

well as other affordable housing may be permitted with a conditional use permit. The standard intensity of development is a floor area ratio of .5:1 and the maximum intensity of development is a floor area ratio of .75:1.

### **Community and Other Designations**

**Community Facilities:** The Community Facilities designation includes a wide range of public and private uses, distributed throughout the community such as schools, churches, child care centers, transportation facilities, government offices and facilities, public utilities, libraries, museums, art galleries, community theaters, hospitals and cultural and recreational activities. The standard intensity of development is a floor area ratio of .4:1 and the maximum intensity of development is a floor area ratio of 1.0:1. See comment 39

**Recreation/Open Space:** The Recreation/Open Space designation includes both public and private recreational uses necessary to meet the active and passive recreational needs of area residents and visitors as well as open space uses necessary to preserve public views, scenic natural land forms such as bluffs, and environmentally sensitive habitat areas. Recreational activities include golf course driving ranges, community recreational facilities, public parklands and indoor and outdoor sports/athletic facilities. Recreation uses include museums, galleries, outdoor theater, and other similar uses. Open Space uses include public view preservation, habitat restoration projects and other similar uses. The standard intensity of development is only an assumed average City-wide and does not apply to each parcel of land.

**Transportation Corridor:** The Transportation Corridor designation applies to the land within the corridors for the Interstate 5 Freeway, the Atchison, Topeka and Santa Fe railway, and Circulation Element roadways. Lands within these corridors are reserved for transportation purposes as the primary use. Secondary uses, such as open space linkages and landscaped areas, public and private parking areas, and other transportation-related activities and facilities are allowed. The standard intensity of development is a floor area ratio of .1:1 and the maximum intensity of development floor area ratio is .2:1.

**Harbor Marine Land:** The Harbor Marine Land designation

## **SPECIFIC PLAN AREAS**

---

The estimated numbers of residential dwelling units and population are expressed as ranges to coincide with the structure of the residential land use designations which are also Residential 7-14, and so forth). The population range expressed in Table LU-4 is based on the recognition that population per dwelling unit varies depending on unit type and size, as well as the social or cultural mixture within the City.

Five areas within the City are identified as Specific Plan areas for future development, or revitalization. These areas include the Headlands, the Town Center, Doheny Village, Monarch Beach and the Dana Point Harbor. The characteristics of planned land use for each focal area are described in the following sections.

### **Headlands**

The Dana Point Headlands represents a significant land resource that has the capacity to accommodate a mixture of compatible land uses, including visitor/recreation commercial, residential, recreation/open space, and community facilities. The Headlands area is identified as a Specific Plan area on the Land Use Policy Map. The Specific Plan for the Headlands will be prepared before development occurs and that plan will implement General Plan policy by establishing development standards, precise locations for land uses and facilities, locations for streets, standards for residential density and non-residential intensity, and standards for the use and conservation of natural resources.

Identification of the percentage mixture of planned land use is designed to provide both the City and property owner with the flexibility needed to allow consideration of alternative development designs. Any alternative designs must generally meet the basic land use percentage descriptions contained in this element and noted on the Land Use Policy Map. Any development design for the Headlands must include open space linkages connecting on- and off-site open space areas, and any land area designated specifically as Community Facility will result in a corresponding reduction of land area designated as either Visitor/Recreation Commercial or Residential 3.5-14, or both. The Land Use Element can be amended when a Specific Plan is prepared for the property.

## **Monarch Beach**

The Monarch Beach Specific Plan area is defined geographically by the Salt Creek Basin, a major drainage course lying between Crown Valley Parkway and Niguel Road. Relatively recent master planning and recent high quality construction established Monarch Beach as a planned recreation-oriented resort and residential area. Monarch Beach includes land planned for a mixture of Visitor/Recreation Commercial, Community Commercial, Open Space and Residential development. The locations of these uses within the focus area are depicted in Figure LU-9. See comment 40



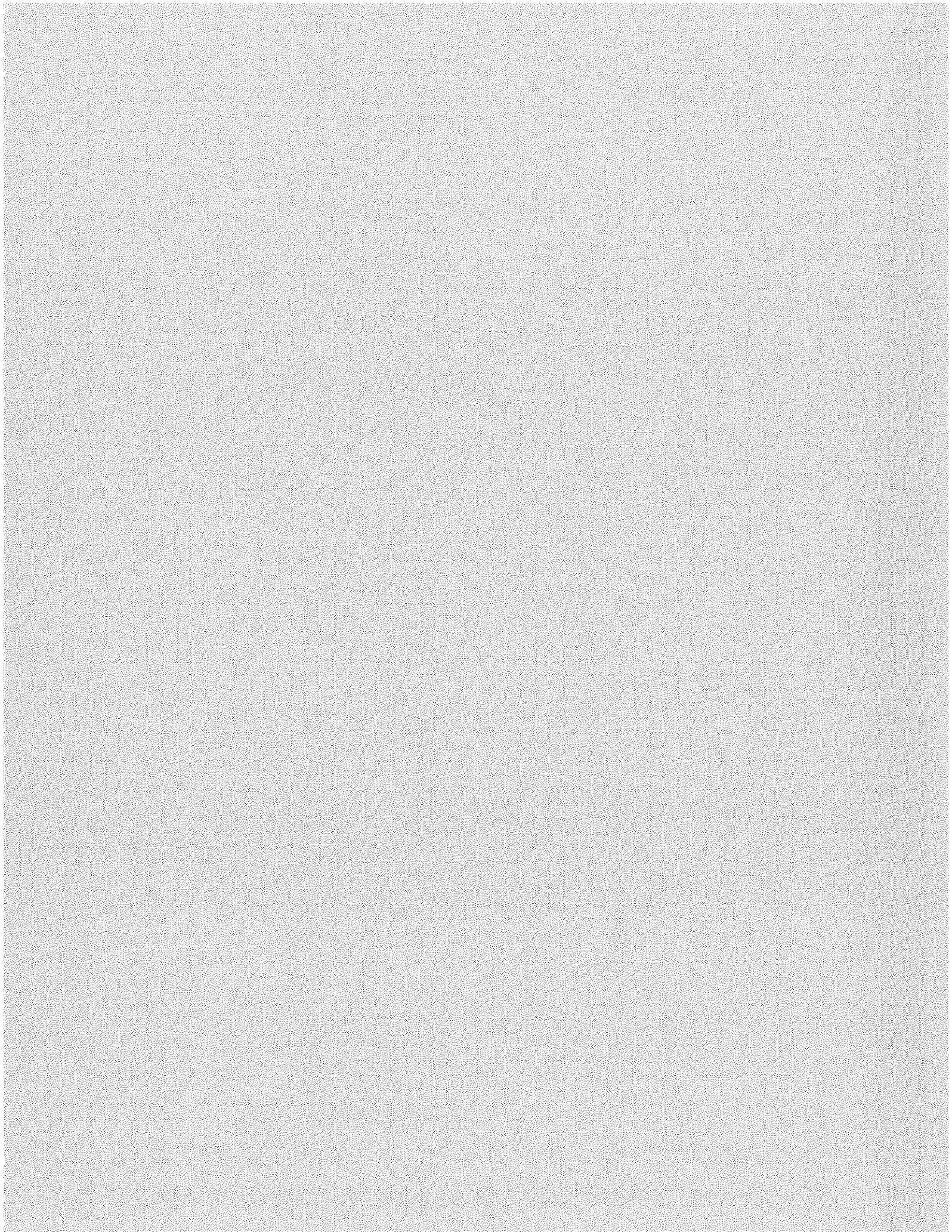

# CITY OF DANA POINT NOISE ELEMENT

## COMMENTS

1. Because of the reverberating amplifying amphitheater characteristics of the Salt Creek Canyon, sounds from the ten-year construction project will make the neighboring homes uninhabitable. Placing the staging area at the east end of the project, on top of the fill, will further exacerbate the problems of noise and pollution. Current use of the site creates objectionable noise problems at all hours of the day and night and on all days of the week. For almost two years the residents of Ritz Pointe put up with noise until midnight from a skateboard park the church constructed on the east side of the property. There were also very loud teen parties, again on the east side of the property, that were unchaperoned and resulted in police intervention. The church has not been a responsible neighbor in the past.

2. Now residents go to sleep to the sound of the waves at Salt Creek Beach. The developers must guarantee not to interfere with that current level of sound. Even when the project is built out, the noise from the schools (K through Eighth Grade in the original proposal and verified by the City Planner), the playgrounds and the rental facilities, which will all face the residential developments to the east unbuffered, will become a permanent daily fixture in the residents' lives.

3. The communities to the east of the project, in a direct line of sight 700 feet across the amplifying valley, include residents who are retired or work from home, who have outdoor living areas facing the development, who use the Salt Creek Park, Trail and Corridor and who engage in recreational activities, including golfing, which generates significant revenue for Dana Point. Many residents are seniors who paid a premium to live in an area of peace and quiet and who face selling their homes at a great reduction of fair value because they must disclose that there is a ten-year construction project across Salt Creek Corridor.

4. The developer has ignored all the residents and activities to the east, doing nothing to mitigate the line-of-sight noise. In fact, the so-called below-grade buildings are all above grade on the east side of the project, sending the noise, unimpeded, directly into the residences on the other side of Salt Creek Corridor.

5. The developers refused to give any consideration to the noise impacts to the east of the project.

6. The proposed noise levels from the project are unacceptable. The developer refuses to place the playgrounds away from the east side of the bluff.
7. The developer has no intention of considering mitigation of the impact of noise to the east.
8. A ten-year construction zone will destroy the livability of most of Monarch Beach.
9. The design of the development will create excessive and unnecessary noise levels.
10. Because this project is surrounded on all sides by quiet residential areas, it must be held to the quiet residential standard.
11. The developer asserts that it does not have to demonstrate anything to protect the neighbors to the east from excessive noise.

## **INTRODUCTION TO THE NOISE ELEMENT**

---

The control of noise is an essential part of preserving the quality of a community. The development of effective strategies to reduce excessive noise in the community is essential to creating a safe and compatible living and working environment. Since 1971, the Noise Element has been one of the seven mandatory elements of a California General Plan. Due to California's rapid growth, noise elements are required to enable cities to limit exposure to excessive noise levels.

## **PURPOSE OF THE NOISE ELEMENT**

---

The Noise Element of a General Plan is a comprehensive program for including noise control in the planning process. It is a tool for achieving and maintaining environmental noise levels compatible with land use. The Noise Element identifies noise sensitive land uses and noise sources, and defines areas of noise impact. The Element establishes goals, policies, and programs to ensure that Dana Point residents will be protected from excessive noise. See comment 1

## **SCOPE AND CONTENT OF THE ELEMENT**

---

The Noise Element follows the recently revised State guidelines in the State Government Code Section 65301(f) and Section 46050.1 of the Health and Safety Code. The Element quantifies the community noise environment in terms of noise exposure contours for both near- and long-term levels of growth and noise-generating activity. The information will become a guideline for the development of goals and policies to achieve noise compatible land uses. This information also identifies baseline noise levels and sources for the identification of local noise ordinance enforcement. The Element is divided into three sections as follows:

- 1) Introduction - including a description of the Purpose and Scope of the Element, an Inventory of Current and Forecast Conditions describing the existing and future noise levels in the City, and Issues Identification presenting the noise issues in the City that are to be

addressed within the Noise Element.

- 2) Goals and Policies - defining the goals and policies of the Noise Element and the City's general approach to achieve stated goals.
- 3) The Noise Plan - defining strategies that the City will implement to achieve the goals of the Element.

## **INVENTORY OF CURRENT AND BUILD-OUT CONDITIONS**

---

The inventory contains a detailed description of the current and build-out noise environments within the City of Dana Point. These descriptions of the noise environments are based on an identification of noise sources and noise sensitive land uses, an existing community noise measurement survey, noise contour maps, and build-out projections of noise. See comment 2

### **Sources of Noise**

Major noise sources in Dana Point include freeways, railroads, major and minor arterial roadways, and significant noise generating stationary sources. These can be grouped into two basic categories, transportation sources (primarily traffic) and non-transportation sources. Each source and its impact on the noise environment of Dana Point is summarized in the following paragraphs and discussed in greater detail in the Technical Appendix.

The most significant and common source of noise in urban areas is transportation related. It includes automobiles, trucks, buses, motorcycles, railroads, aircraft and harbor activities. Motor vehicle noise is of concern because of its high rate of occurrence and roadway proximity to noise sensitive areas.

The City of Dana Point is bisected by a number of arterial roadways and is near the San Diego Freeway. The major east-west roadways in Dana Point are Camino Del Avion, Stonehill Drive, Selva Road, Pacific Coast Highway, Del Prado, and the San Diego Freeway. The major north-south roadways in the City include Crown Valley Parkway, Niguel Road, Street of the Golden Lantern, Del Obispo, Doheny Park Road, and Camino de Estrella. Some additional roadways carry significant traffic levels and have residential land use directly adjacent to the

roadway.

The Atchison, Topeka and Santa Fe Rail Road has a railway line running through Dana Point. The line runs parallel to the San Diego Freeway; as the freeway turns southeast, the railroad tracks separate from the freeway to run adjacent to Capistrano Beach. Traffic primarily consists of passenger trains; however, a few freight trains pass through the City each day.

Other sources of noise within the City are from non-transportation sources including industrial and commercial activities, sport activities within public and private parks, construction, and human activities. The South East Reclamation Regional Authority (SERRA) Wastewater Treatment Plant is also a significant source. Noise from trucks at commercial loading areas have also been identified as a source of noise.

Ocean waves are also audible, particularly at night, through much of Dana Point. Noise, however, is commonly defined as "unwanted sound" and the ocean sounds are not considered a problem.

Harbor noise can be heard in many of the areas of Dana Point adjacent to the harbor. Noise sources in the harbor area include boats, jet skis, and motor vehicle traffic. Periodically, dredging activities can occur, which can be major sources of noise. Much of the harbor property belongs to the County of Orange. Any activities that occur within the harbor would be subject to the County of Orange Noise Ordinance.

### **Noise Sensitive Receptors**

The most predominant and noise sensitive land use in Dana Point is residential. This land use is considered especially noise sensitive because (1) considerable time is spent by individuals at home, (2) significant activities occur outdoors, and (3) sleep disturbance is most likely to occur in a residential area.

Additionally, the City of Dana Point has a number of public and private educational facilities, churches, a hospital, a library, senior housing, and park and recreation facilities that are considered noise sensitive. The location of residential areas, schools and parks are shown on the General Plan land Use Policy Map. See comment 3

Wastewater Treatment Plant. Noise measurements made around and inside the SERRA Wastewater Treatment Plant suggest that noise levels attributable to the plant are not in excess of City standards.

### **Noise Control**

A local government has little direct control of transportation noise at the source. State and Federal agencies have the responsibility to control vehicle noise emission levels. Mitigation through site planning and the design and construction of noise barriers (wall, berm, or combination wall/berm) are the most common ways of alleviating traffic noise impacts in existing urban environments. Figure N-4 illustrates some of these ways. The effect of site planning and noise barriers are critically dependent on the geometry between the noise source and the receiver. Noise reduction generally occurs when the "line of sight" between the source and receiver is penetrated by a barrier. The greater the penetration, the greater the noise reduction.

See comment 4

Sound waves will continue to bend around a soundwall; however, the resultant noise level will usually be at least 5 dB less than noise with a direct line of sight between the observer and the source. The more the noise is forced to bend or refract, the greater the noise reduction up to a maximum of around 20 dB. Setbacks can also be used to provide partial mitigation or mitigation where a minimal noise reduction is needed. Moving a residential unit from 50 feet from the centerline to 100 feet from the centerline only reduces the noise levels by 3 to 4.5 dB. That is, doubling the distance from the centerline of the roadway reduces noise levels by 3 to 4.5 dB. The distance must be quadrupled to achieve a noise reduction of 6 to 9 dB. This compares to noise barriers which provide a 5 dB reduction just by breaking line of sight and can provide up to 29 dB of noise reduction. In general, the higher the noise barrier the greater the noise reduction. The height necessary, the barrier materials, and location of barrier are engineered on a project-by-project basis.

The standards and criteria shown in Tables N-1 and N-2 specify acceptable limits of noise for various land uses throughout the City. These standards and criteria will be incorporated into the land use planning process to reduce future noise and land use incompatibilities. Table N-1 presents criteria used to assess the compatibility of proposed land uses with the noise environment. These criteria are the basis for the development of the specific

**Goal 3: Develop measures to control non-transportation noise impacts.**

**Policy 3.1:** Adopt a City Noise Ordinance to control excessive noise from lawn blowers, trimmers, machinery or other disturbances. This Ordinance should be consistent with the Orange County Noise Ordinance to promote mutually enforceable standards which result in a quality noise environment.

**Policy 3.2:** Evaluate and develop measures to reduce noise generated by construction activities.

**Policy 3.3:** Establish and maintain coordination among the appropriate agencies involved in noise abatement.

**RELATED GOALS AND POLICIES**

---

Certain policies included in the Noise Element serve as coastal resources planning and management policies that are part of the City's Local Coastal Program (LCP). Table N-3 identifies the required components or issue areas of the LCP included in the Noise Element.

The goals and policies described in the Noise Element are related to and support subjects included within other General Plan Elements. Many goals and policies from the other Elements directly or indirectly support the goals and policies of the Noise Element. These supporting goals and policies are identified in Table N-4.



---

## THE NOISE PLAN

---

The Noise Plan describes the approach to be used in implementing the Noise Element goals and policies. In order to achieve the goals and objectives of the Noise Element, an effective implementation program developed within the constraints of the City's financial and staffing capabilities is necessary. The underlying purpose is to reduce the number of people exposed to excessive noise and to minimize the future effect of noise in the City. The following are the actions that the City should consider implementing to control the impacts of noise in Dana Point.

### TRANSPORTATION NOISE CONTROL

---

The most efficient and effective means of controlling noise from transportation systems is to reduce noise at the source. However, since the City has little direct control over source noise levels because of State and Federal preemption (i.e., State Motor Vehicle Noise Standards and Federal Air Regulations), policies should be focused on reducing the impact of the noise on the community. Cooperative efforts with State and Federal offices are essential.

Within the City of Dana Point are a number of transportation related noise sources including train tracks, a freeway, major arterials, collector roadways and a waste water plant. These sources are the major contributors of noise in Dana Point. Cost effective strategies to reduce their influence on the community noise environment are an essential part of the Noise Element.

#### Strategy 1

Ensure the employment of noise mitigation measures in the design of roadway improvement projects are consistent with funding capability. Support efforts by the California Department of Transportation and others to provide for acoustical protection of existing noise sensitive land uses affected by these projects. Consideration of soundwalls will be requested as part of any Caltrans roadway project. Of particular concern will be the Stonehill Drive/freeway connection and improvements to the Pacific Coast Highway freeway connection. Additionally, Caltrans will be requested to review the sound wall design along the freeway near the east end of the City.

### **Strategy 2**

Encourage the use of walls and berms in the design of residential and other noise sensitive land uses that are adjacent to major roads, commercial, or industrial areas.

### **Strategy 3**

Provide for continued evaluation of truck movements and routes in the City to provide effective separation from residential or other noise sensitive land uses.

### **Strategy 4**

Enforce the State Motor Vehicle noise standards for cars, trucks, and motorcycles through coordination with the California Highway Patrol and the Dana Point Police services.

## **NOISE AND LAND USE PLANNING INTEGRATION**

---

Information relative to the existing and build-out noise environments within Dana Point should be integrated into future land use planning decisions. The Element presents the existing and build-out noise environments so that the City will include noise impact considerations in development programs. Noise and land use compatibility guidelines are presented, as well as noise standards for new developments. Community noise considerations are to be incorporated into land use planning. These measures are intended to prevent future noise and land-use incompatibilities. See comment 5

### **Strategy 5**

Enforce standards that specify acceptable limit of noise for various land uses throughout the City. Table N-1 shows criteria used to assess the compatibility of proposed land uses with the noise environment. These criteria are the bases of specific Noise Standards. These standards, presented in Table N-2, define City policy related to land uses and acceptable noise levels. See comment 6

### **Strategy 6**

Incorporation of noise reduction features during site planning to mitigate anticipated noise impacts on affected noise sensitive land uses. New development will be permitted only if appropriate mitigation measures are included such that the standards contained in this Element are met. See comment 7

### **Strategy 7**

Enforce the provisions of the State of California Uniform Building Code which specifies that the indoor noise levels for multi-family residential living spaces not exceed 45 dB CNEL due to the combined effect of all noise sources. The State requires implementation of this standard when the outdoor noise levels exceed 60 dB CNEL. The Noise Referral Zones (60 dB CNEL) can be used to determine when this standard needs to be addressed. The Uniform Building Code (specifically, the California Administrative Code, Title 24, Part 6, Division T25, Chapter 1, Subchapter 1, Article 4, Sections T25-28) requires that "Interior community noise levels (CNEL/LDN) with windows closed, attributable to exterior sources shall not exceed an annual CNEL or LDN of 45 dB in any habitable room". The code requires that this standard be applied to all new hotels, motels, apartment houses and dwellings other than detached single-family dwellings. The City will also, as a matter of policy, apply this standard to single family dwellings.

## **NON-TRANSPORTATION NOISE CONTROL**

---

People, as well as areas identified as noise sensitive, must be protected from excessive noise from non-transportation sources including commercial and industrial centers. These impacts are most effectively controlled through the application of a City Noise Ordinance. See comment 8

### **Strategy 8**

Adopt and enforce the current County Noise Ordinance as the City's and continue to apply the Noise Ordinance to ensure that City residents are not exposed to excessive noise levels from stationary noise sources. The Ordinance protects people from non-transportation related noise sources such as music, machinery and pumps, air conditioners, the SERRA Wastewater Treatment Plant and truck traffic on private property. The Noise Ordinance does not apply to motor vehicle noise on

public streets, but it does apply to vehicles on private property. The Noise Ordinance is designed to protect quiet residential areas from stationary noise sources. The noise levels encouraged by the Ordinance are typical of a quiet residential area.

See comments 9 and 10

### **Strategy 9**

Require that any proposed development projects, demonstrate compliance with the City Noise Element and Ordinance prior to approval. See comment 11

### **Strategy 10**

Require construction activity to comply with limit established in the City Noise Ordinance.

### **Strategy 11**

Designate the Community Development Department to act as the noise control coordinator. This will ensure the continued operation of noise enforcement efforts of the City.

### **Strategy 12**

Review current policy and contracts with the County of Orange Health Department to enforce the Dana Point Noise Ordinance. In cases where the Health Department may have a conflict, contract with an outside firm or agency to conduct compliance monitoring.

### **Strategy 13**

Limit delivery hours for stores with loading areas or docks fronting siding, bordering or gaining access on driveways adjacent to noise sensitive areas. Exemption from this restriction shall be based solely on attaining full compliance with the nighttime noise limits of the Noise Ordinance.

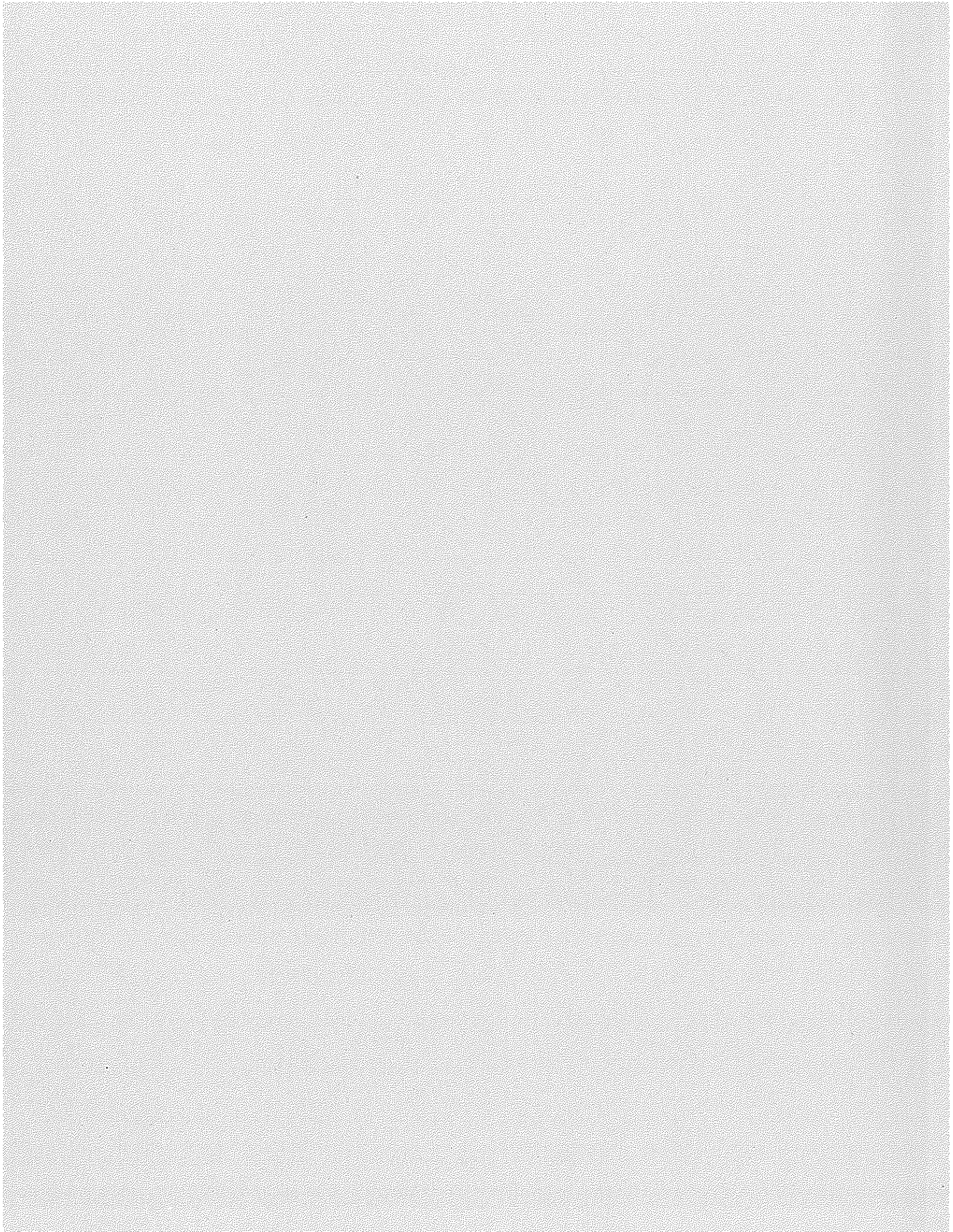

CITY OF DANA POINT  
PUBLIC FACILITIES/GROWTH MANAGEMENT  
ELEMENT

COMMENTS

1. The developer should be held to the same standards as all other projects in Monarch Beach.
2. In fact, the existing facilities of the developer are not in compliance with the storm drainage conditions required for Salt Creek or for Monarch Beach. The storm drains are actually totally non-functional.
3. All parts of the planning process are interrelated and interdependent. Contrary to this mandate, the developer has chosen to act only in its own interest to the detriment of neighbors and neighboring communities.
4. The proposed project will take place on a parcel that is neither a large area of vacant land nor underutilized. It is an oversized tax exempt project designed to serve primarily non-residents of Dana Point in direct competition with tax-paying commercial facilities.
5. During the ten-year construction phases the developer gives no consideration to circulation. It wants to continue its seven-day-a-week business with no provision for parking and no provision for marshaling and parking the worker vehicles and the earth- and material-moving equipment. To access the site from I-5, they will have to travel down Crown Valley, make a left on Camino del Avion and right to Niguel Road, right on Pacific Coast Highway and right onto Crown Valley Parkway, spewing diesel fumes throughout the area. In the alternative, they will stop in the south-bound lanes of Crown Valley, making left turns onto the project site, disrupting heavily traveled Crown Valley Parkway in both directions.
6. Because it's in its financial interest to do so, the developer wants to avoid sound development phasing. It plans to destroy the natural bluff, then build its non-taxable, revenue facilities. Ten years later it says it will build the necessary parking and other infrastructure, the point at which it will have no more money and no ability to complete the infrastructure. As an example, see the abandoned high tax-revenue, commercial properties at the Headlands, promoted by that developer.
7. To accomplish this, 100% all-phase completion bonds must be required.

8. The developer proposes a very large project on a very small site. Because of the existence of the steeper than 2:1 sloped bluff adjacent to the Salt Creek Scenic Corridor, Trail, Creek, Park and golf course, and the prior dedication of part of their land for Crown Valley Parkway, they actually have less than four acres for their oversized project.

9. The owner has a long history of non-compliance with prior grandfathered, weak environmental constraints, particularly with respect to slope stabilization and storm water drainage. The EIR consultant, LSA, should review all of the prior geologic and geotechnical analyses and reports contained in existing Dana Point records, as well as all of the supporting studies. After reviewing them, LSA should conduct new comprehensive and thorough studies of their own. The site, adjacent to recent landslides that totally destroyed two multistory buildings, is a geologic nightmare for school children attending school and playing on the bluff top. No examination has been made of the impact of the project and resulting new facilities on the Salt Creek drainage basin, on the new waste water treatment plant or on Salt Creek Beach.

10. The full impact of the project on currently non-functioning storm drains must be considered.

11. We know that the existing surface water runoff plan and storm water drainage plan are inadequate for the existing facility. The developer's plans appear to continue the same system without modification, maintenance or upgrading. At the same time the developer will increase the impervious surface by thousands of square feet.

12. The rains of January and February 2010 clearly demonstrate that the developer fails to manage storm water run off and surface drainage, resulting in unacceptable erosion on the unstable bluff and washouts and trail closures in the Salt Creek Basin. The impact on the Salt Creek Treatment Plant and Salt Creek Beach has not been evaluated. Although the developer maintains there is no subterranean run off of water from the bluff top, recent rains have clearly shown the existence of numerous large subterranean channels dispersed throughout the bluff slope.

---

## INTRODUCTION TO THE PUBLIC FACILITIES/ GROWTH MANAGEMENT ELEMENT

---

The City of Dana Point is part of a large and fast-growing region. Population growth and the provision of public facilities must be viewed in this regional context. However, assuring adequate levels of public service and maintaining a desirable quality of life through regulation of growth are options available to the City within certain jurisdictional, fiscal, and legal limits. The Public Facilities/Growth Management Element establishes a plan for ensuring that future growth is coordinated with the provision of public services and facilities so that desirable level of service standards and community qualities important to the citizens are maintained. This element addresses growth management issues on a local and regional level. The goals, policies, and plan contained in this element stem from considerable background research, which is summarized in the Public Facilities/Growth Management Technical Report. See comment 1

### **PURPOSE OF THE PUBLIC FACILITIES/GROWTH MANAGEMENT ELEMENT**

---

The Public Facilities/Growth Management Element has two interrelated purposes: to plan for adequate public services and facilities, and to coordinate new development with the provision of public facilities. While many public facilities issues will be addressed independently from growth management issues, a significant portion of the Element deals with the overlap between the two subjects.

The Public Facilities/Growth Management Element is an optional Element of the General Plan. However, once adopted this Element carries the same force and effect as a required Element and must be internally consistent with other Elements of the General Plan.



## STORM DRAINAGE

---

The City's storm drain system consists of regional and local facilities. The regional facilities, including the San Juan and Salt Creek storm channels, are owned and maintained by the Orange County Flood Control District. The local storm drains, once owned and maintained by the County, became the responsibility of the City upon its incorporation. Currently, the City contracts with the Orange County Environmental Management Agency to maintain the local storm drains.

While the Salt Creek channel through Dana Point has undergone all necessary improvements to convey a 100-year flood, the San Juan Creek Channel has not. The Orange County Flood Control District is in the process of planning and executing additional improvements to the San Juan Channel so that it will be able to convey a 100-year flood.

See comment 2

Local storm drains throughout the City were constructed on a piecemeal basis as new development was approved. Information about the type and age of these facilities has not been assembled, and the condition of these facilities is generally not known. One of the City's main public facilities tasks is to assess the condition of these facilities and develop a capital improvements program for the system.

A 1989 Orange County report evaluated flooding problems in the Capistrano Beach area. The report recommends specific improvements, such as new curbs and improved storm drains, to address the flooding problem; however, these improvements have not yet been made. According to Orange County Flood Control District staff, the flooding problems in this area require additional study.

The following policies are incorporated into this Element to ensure that local facilities are maintained and replaced as needed.

**GOAL 2: Maintain and improve portions of the storm drainage system for which the City is responsible and encourage adequate maintenance of other portions of that system.**

**Policy 2.1:** Identify local storm drainage deficiencies and develop a capital improvements program for the correction and replacement of aging or inadequate drainage system components. (Coastal Act/30233, 30235, 30236, 30253)

service unit and provide adequate space.

**Policy 4.3:** Increase community participation in the neighborhood watch groups and other public safety service programs.

**Policy 4.4:** Assure adequate sites for primary care (internists, family practitioners, and obstetricians-gynecologists) facilities in the community.

**Policy 4.5:** Coordinate with the Orange County Sheriff's and Fire Departments for the continued provision of adequate law enforcement and fire protection.

**Policy 4.6:** Coordinate sheriff facility and traffic facility planning where necessary to maintain adequate levels of law enforcement service.

## **COMMUNITY, CIVIC, EDUCATIONAL AND CULTURAL FACILITIES**

---

The City's community, educational and cultural facilities are important vehicles for political, social, and cultural enrichment in the community.

The Capistrano Unified School District (CUSD) administers public schools for Dana Point. Although two of the District's elementary schools are located within the City, most of the schools attended by Dana Point students are located outside the City. The District has experienced rapid growth in recent years, with the result that enrollment at most of the schools attended by Dana Point students exceed their original design capacity. While temporary classrooms are used to house the extra students, new permanent facilities are needed. Because State funding sources are scarce and give priority to schools with year-round calendars, the District is considering converting to year-round operations in order to obtain State funds for new facilities.

The County of Orange library system provides library services to Dana Point through the Dana-Niguel Branch Library and two other libraries in the Cities of San Clemente and San Juan Capistrano. Based upon the ratio of library size to population, service levels at these libraries meet County of Orange standards. Based upon level of service criteria and planned facilities, these levels of service will continue to be maintained

and space for community events.

**Policy 5.5:** Consider the need for a local historical museum (Coastal Act/30213).

**Policy 5.6:** Assess the cultural facilities needs for the City, including the need to expand existing facilities.

**Policy 5.7:** Encourage well-planned neighborhood and community park facilities that are within convenient distance to all residential areas.

**Policy 5.8:** Coordinate the approval of new development with the capacity of the Capistrano Unified School District.

**Policy 5.9:** Ensure to the extent feasible that adequate sites are available for public facilities, churches, schools, museum(s), government offices, a civic/cultural center or other facilities that may serve the public interest.

**Policy 5.10:** Develop a program for public art.

**Policy 5.11:** Consider creating various funding mechanisms, such as developer impact fees, to contribute toward the cost of new civic facilities.

**Policy 5.12:** Coordinate the provision of community facilities with the development of new parks and recreational facilities.

## **PUBLIC UTILITIES**

---

The San Diego Gas and Electric Company and Southern California Gas Company provide electrical and natural gas service to the City of Dana Point. No deficiency exists in the existing electric and natural gas systems in the City, and both companies state that they will be able to expand to accommodate any future growth in the City.

The City relies principally upon conventional energy resources to meet its needs. However, active solar heating is relatively cost effective and is currently underutilized in the City.

project contributes measurable traffic must be constructed and completed to attain Level of Service (LOS) "C" at the intersections on primary arterials, secondary arterials and local streets, and LOS "D" at intersections on major arterials and State highways under the sole control of the City/County.

**Policy 7.3:** Develop a program to monitor new development to ensure compliance with adopted level of service standards.

**Policy 7.4:** Require that all development projects participate in comprehensive public facility financing plans on a pro-rata basis as a condition of development approval, except where an increased level of participation exceeding these requirements is established through negotiated legal mechanisms.

**Policy 7.5:** Require all new development to pay its share of the costs of mitigating its traffic impacts, including regional impacts. Work with other jurisdictions to determine minimally acceptable impact fee levels.

**Policy 7.6:** Require that all development be phased in accordance with a Comprehensive Phasing Program (CPP). The CPP shall include development phasing plans which establish phasing allocation commensurate with roadway and public facility capacities and an overall buildout development plan which can be supported by the implementation of the planned infrastructure.

**Policy 7.7:** Develop a Capital Improvement Program to meet and maintain adopted level of service standards for traffic and public services.

**Policy 7.8:** Promote traffic reduction strategies through TDM measures.

**Policy 7.9:** Require development of large properties to include a master plan and an environmental analysis of the proposed development. (Coastal Act/30250)

**Policy 7.10:** Ensure that growth management policies are consistent with the policies of the General Plan.

**Policy 7.11:** Require development of large properties to prepare a comprehensive development plan and environmental analysis to evaluate the impacts of the proposed project. (Coastal Act/30250)

## **INTER-JURISDICTIONAL COORDINATION AND COOPERATION ON GROWTH MANAGEMENT ISSUES**

---

Due to the number of agencies involved in growth management-- including the State of California, SCAG, the South Coast Air Quality Management District, the County of Orange, and local jurisdictions the City must coordinate its growth management efforts closely with these other agencies.

There are several key areas discussed below in which inter-jurisdictional coordination and cooperation are important.

**Facility Implementation Plans:** The Orange County Facility Implementation Plans (FIPs) are essentially conceptual planning and financing plans for sheriff, fire, storm drain, library, and transportation services in the County. These plans address the planning and financing of many of the City's contract services. The City will evaluate the service standards contained in the FIPs in order to make sure they meet the City's needs. Furthermore, in the FIPs, the County of Orange suggests that local jurisdictions may need to assist with financing facilities for which funding is uncertain (such as sheriff and library services). Therefore, the City will consider working with the County to evaluate its potential participation in funding mechanisms (i.e., the Fee Program for sheriff and library services).

---

## PUBLIC FACILITIES/GROWTH MANAGEMENT PLAN

---

The Public Facilities/Growth Management Plan has two parts: the Growth Management Plan, and the Public Facilities Plan. The Growth Management Plan describes the City's integrated approach to growth management and depicts land areas in the City most likely to be subject to the Plan. The Public Facilities Plan describes the location and existing level of service standards for the City's public services.

While these plans are described separately, they are strongly interrelated. For example, the Growth Management Plan calls for coordinating with the County of Orange in future public services planning and adopting level of service standards for public services. See comment 3

### THE GROWTH MANAGEMENT PLAN

---

In terms of new development, there are certain areas of the City that will be the most strongly affected by the City's Growth Management Plan. These include primarily large areas of vacant and underutilized land. Figure PF-1 shows the location of these lands. See comment 4

The City's Growth Management Plan includes all of the components required by Measure M, the Traffic Improvement and Growth Management Ordinance, as well as additional components tailored to the City's unique needs and goals. In terms of the Measure M requirements, this Element establishes a basic policy framework for managing growth, as well as specific level of service standards for public facilities. Additional implementation programs independent of this Element will be required in order to implement the Growth Management Plan.

The City's Growth Management Plan includes the following main components. The first six of these components are intended to comply with Measure M requirements:

**Traffic Level of Service Goals:** Policy 7.2 of this Element requires that development make necessary improvements to the

circulation system to maintain acceptable LOS levels at intersections under City control. Roadway expansions will be planned as part of the Capital Improvement Program and phased according to the Comprehensive Phasing Program. The LOS goals will be enforced through conditions of approval and monitored annually through the Performance Monitoring Program. See comment 5

**Public Facility Standards:** Pursuant to Policy 7.1, the City will adopt performance criteria for law enforcement, fire, library, storm drain, and parks/open space facilities (see Table PF-1). Future facilities will be determined as part of the Capital Improvements Program. Impact fees will be levied on a pro rata basis, and the balancing of new facilities with development will be monitored under the Performance Monitoring Program.

**Development Phasing:** The purpose of development phasing is to ensure that adequate infrastructure (roadways, utilities) are added as development proceeds so that the provision of these facilities is in balance with demand. In Dana Point, the primary emphasis of the development phasing will be upon roadways, although the larger undeveloped tracts in the City will also require new water, sewer, and storm drain service. While the Comprehensive Phasing Program will provide plans for new facilities, the Performance Monitoring Program will provide annual evaluation of compliance with phasing plans in order for development to continue. See comment 6

**Performance Monitoring:** The Performance Monitoring Program will establish a system for annual evaluation of compliance with development phasing allocations. Under this program, roadway and other public facility improvements or fundings must actually be provided in order for new development to continue. See comment 7

**Capital Improvement Plans:** The purpose of the Capital Improvement Plans is to estimate future development over a seven year period and determine the necessary infrastructure and associated costs required for this new development. The Capital Improvement Plans will be closely linked with the Comprehensive Phasing Plans.

**Interjurisdictional Cooperation:** The City will become involved in interjurisdictional coordination for various purposes, including:

- Working with interjurisdictional forums (such as the City-County Coordinating Committee) to make sure that the City's fees are consistent with minimally acceptable impact fees for application within the larger Growth Management Area;
- Participating in interjurisdictional forums at the Growth Management Area (GMA) level to discuss developments with multi-jurisdictional impacts and appropriate mitigation measures;
- Working with these forums to develop strategies for bringing about greater jobs/housing balance at the subregional level; and
- Cooperating with the County of Orange in implementing the Facility Implementation Plans and possibly collaborating in the Development Monitoring Program.

**Comprehensive Development Plans for Large Projects:** The City will require that any new large developments (such as any development proposed for the Dana Point Headlands) prepare a comprehensive development plan and environmental impact analysis. A Specific Plan is an example of a Comprehensive Development Plan for large projects. This will allow the city to anticipate the impacts of large projects prior to development of any portion of the projects, and permit more time to plan for public services and facilities needed to support the projects.

See comment 8

**Coordination of Adjacent Jurisdictions:** Apart from coordination with subregional interjurisdictional forums (such as the City-County Coordinating Committee), the City will separately work with its immediate neighbors to develop mutual agreements for review and possible conditioning of development projects.

## **THE PUBLIC FACILITIES PLAN**

---

The Public Facilities Plan consists of two parts: Infrastructure and Public Services. Infrastructure includes water, wastewater, storm drain, solid waste, gas, electrical, and telecommunications systems. Public services include law enforcement, fire protection, emergency medical, educational services and civic and cultural institutions. See comment 9



Figure PF-2 depicts the areas of the City designated for community facilities on the City's Land Use Plan. Community facilities include schools, churches, child care, library facilities, government offices, utilities, cultural and recreational facilities. The Land Use Plan also allows community facilities in three commercial land use categories including the community commercial, neighborhood commercial, and visitor recreation commercial categories (See Land Use Element).

### **Infrastructure**

Except for storm drains, virtually all of the City's infrastructure is operated and maintained by the County or an independent agency or special district. The policies of this Element emphasize coordination of services with these agencies and conservation of such resources as water and energy. See comment 10

Figures PF-3 through PF-6 depict existing and planned infrastructure. Because the City is largely built-out, these facilities are already in place. The location of some of the infrastructure needed to serve future development on vacant land (such as the Headlands) has not yet been determined.

Most of the information contained in this section is based upon plans provided by the County, independent agencies, and districts.

**Water Distribution:** The City's water distribution system is described in the Master Environmental Assessment (MEA) and Technical Report. Four independent water districts, each with its own board of directors, serve the City. Figure PF-3 shows the location of the water districts and facilities in the City. While the existing water distribution systems throughout the City are in good condition, as these systems age coordination among these districts will be necessary in order to have consistent levels of service in the future. Water conservation is important in the City. The Public Facilities/Growth Management Element policies emphasize support for coordination between the water districts as well as for water conservation. As part of its Growth Management Plan, the City will also investigate the feasibility of involving water districts in a mitigation fee program.

**Storm Drains:** The City's local and regional storm drain systems are depicted in Figure PF-6. The Orange County Flood Control District (OCFCD) manages the regional facilities. Conceptual master plans for regional drainage are provided in the Facilities Implementation Plans (FIPs) of the Growth Management Plan. The FIPs indicate that existing improvements in the San Juan Creek Channel are insufficient to convey a 100-year flood and that additional improvements are needed to sustain a 100-year flood. The OCFCD is in the process of planning and executing these improvements.

Little is known about the condition of the local storm drain facilities, which became the City's responsibility upon incorporation. While the County has a master plan for financing local facilities, a comprehensive plan for local storm drain facilities does not exist; nor has the County maintained records on the condition of local storm drains. In essence, local storm drains have been planned and built on an ad hoc basis. Subdivision plans containing information about the age and type of these storm drains must be obtained from the County, and the condition of the lines must be assessed. See comment 11

The City shall adopt the County standard of providing 100-year flood protection for residents and non-floodproof structures and initiate a capital improvements plan for storm drain facilities which will include level of service standards. See comment 12

### **Public Services**

Several of the City's public services, such as law enforcement, fire/paramedic, and libraries, are provided under contract with the County of Orange. Public education is provided by the Capistrano Unified School District. Therefore, much of the City's future planning of these services involves coordination with other agencies.

The future phasing of law enforcement, fire, and library facilities for the County is provided for by the Facilities Implementation Plans (FIPs) of the Orange County Growth Management Plan. There are separate FIPs for each of the Growth Management Areas (GMAs) in the County. Dana Point falls within two of these GMAs, as shown in Figure PF-7.

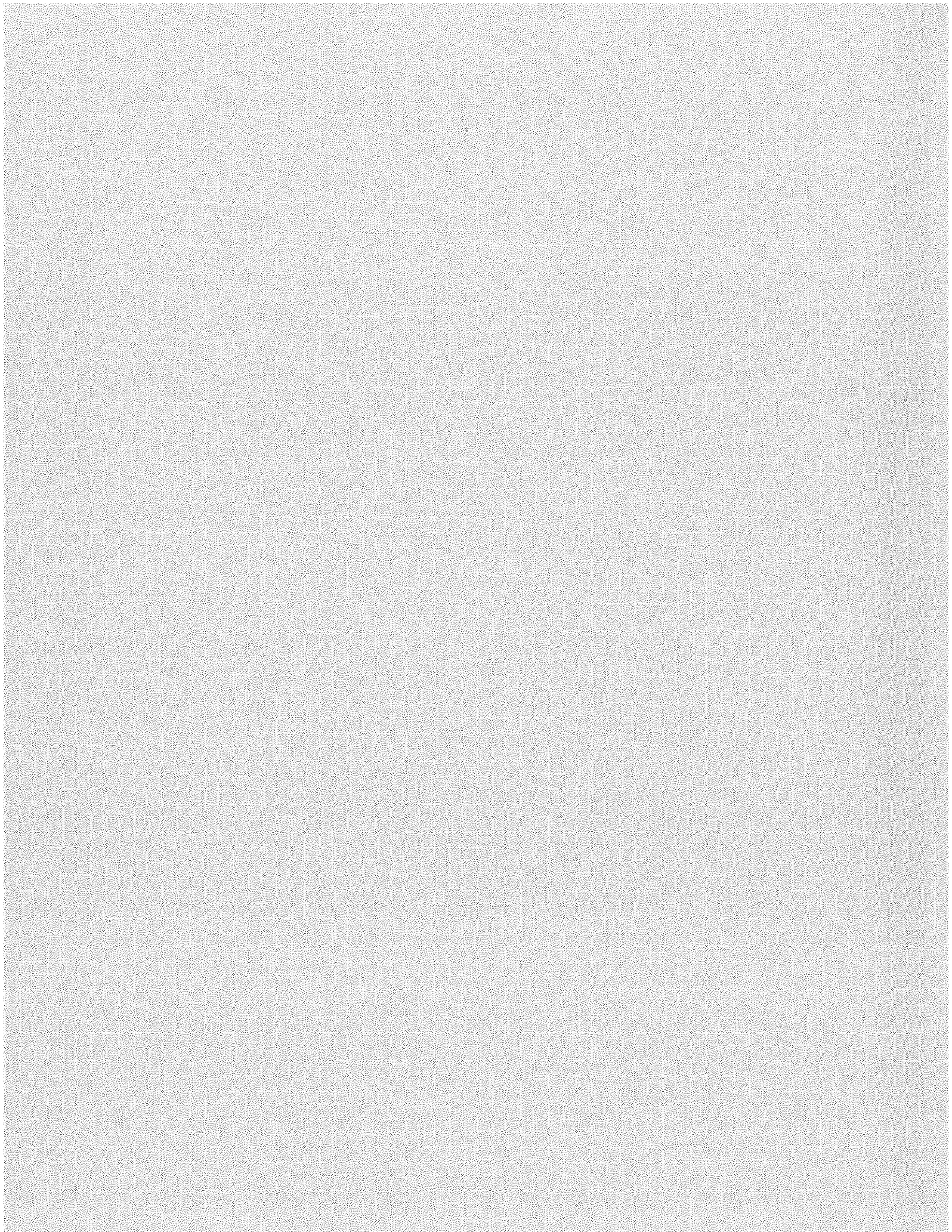

# CITY OF DANA POINT PUBLIC SAFETY ELEMENT

## COMMENTS

1. With respect to the site and project, the developers and their consultants have failed to evaluate public safety impacts of geologic and seismic activity. There must be a thorough review of all prior findings, including all of the long-ignored recommendations of the city engineers. The site and plans must be evaluated in consideration of the recent and historical landslides on neighboring sites. The storm water and irrigation run-off create innumerable real and potential public health and safety impacts. The developers improperly and illegally propose cutting off the top of the bluff and then illegally backfilling into the scenic corridor, backfilling above the Monarch Beach backbone—the Salt Creek Trail, Scenic Corridor, Creek and golf course. Each of the highlighted items must be carefully evaluated.
2. The ten-year duration of the project will interfere with coastal evacuation routes along Crown Valley, Pacific Coast Highway, Niguel Road and Camino del Avion, especially if trucks must turn left on Crown Valley Parkway or if the trucks are staged along Crown Valley Parkway.
3. Prior geologic examinations of the slope, showing geologic instability and the actual landslide with loss of two apartment buildings immediately to the north on the same slope and bluff, have been ignored by the developer for more than 30 years.
4. Rather than maintaining existing setbacks, the developer intends to excavate and backfill over the slope and bluff immediately above the Salt Creek Trail.
5. Instead the developer intends to build beyond the existing bluff top.
6. Policy 1.6 says the project cannot be made to work.
7. On the contrary, if not scaled back, the project can only be described as irresponsible and insensitive.
8. A scaled-back project west of the existing building/foundation line could be made to work.
9. Please follow this mandate.

10. Cheryle Hodge, in the original discredited MND, did properly identify the site as a sensitive bluff top. For the project to proceed, they must protect the bluff top and slope by keeping all new buildings west of the existing building foundation lines.

Note: The MND was discredited because it was presented as an analysis conducted by an independent third party, i.e., Cheryle Hodge, who is in fact a member of the church and served as deputy chairman of the building committee for this project when this study was done.

11. What is the impact of the project run-off on Salt Creek Beach? The excess of unfiltered run-off will force the Salt Creek Water Treatment Facility off-line, causing beach closure, which ultimately affects tourism.

12. Limit development on lands with seismic, slide, and topographic constraints.

13. Run-off from the project site causes extensive erosion in the Salt Creek Basin, overloading and contaminating the storm water collection system, contributing both to pollution closing Salt Creek Beach and adding to flood control problems in the Salt Creek Basin. The recent erosion also suggests that the site is above a significant unstudied groundwater system. Before any construction commences, groundwater on the entire bluff must be studied.

# INTRODUCTION TO THE PUBLIC SAFETY ELEMENT

---

See comment 1

Public safety is of concern to all citizens. For example, in California, natural events such as earthquakes and flooding occur with some frequency. The citizens of a community must anticipate these public safety concerns. Public agencies such as the City of Dana Point have better capacity to anticipate such events and to prepare to deal with these concerns. Perhaps more importantly the City has a responsibility to regulate development to minimize the potential impacts of uncontrollable events on the safety of its citizens and facilities. The Public Safety Element establishes a plan and program to assure that there is an adequate, coordinated and expedient public response to public safety concerns.

## PURPOSE OF THE PUBLIC SAFETY ELEMENT

---

The purpose of the Public Safety Element is to identify and address those features or characteristics which exist in or near the City which represent a potential danger to the safety of the citizens, sites and structures, public facilities and infrastructure. The Element establishes policies to minimize the danger to residents, workers and visitors; and identifies actions needed to deal with crisis situations (e.g., earthquake, fire, flood). The manner in which emergency response agencies cooperate with one another and with other jurisdictions is a key component of the element.

### Issues Overview

The Public Safety Element is a State-mandated component of a General Plan. Government Code section 65302(g) sets forth a list of hazards that the Element must cover, if they pertain to the City. These hazards are:

- seismically induced conditions, including surface rupture, ground shaking, ground failure, tsunami, and seiche;
- slope instability leading to mudslides and landslides;
- subsidence and other geologic hazards;
- flooding;

- canyon urban fires; and
- evacuation routes. See comment 2

State law permits cities to add safety issues to this list and to delete issues which are not pertinent and to add safety issues to this listing. Potential safety issues were researched and documented for preparation of the Master Environmental Assessment (MEA) and the Public Safety Technical Report that were completed as background document for the General Plan. The following safety issues were added:

- hazardous materials; and
- nuclear hazards from San Onofre Nuclear Generating Station.

## **RELATED PLANS AND PROGRAMS**

---

The Safety Element issues relate closely to certain issues discussed in the Land Use and Conservation/Open Space Elements of the General Plan; for example, restriction of construction on or near unstable bluffs. Dana Point is preparing an Emergency Plan that addresses hazard areas including nuclear, seismic, flooding and hazardous materials. This Emergency Plan will be reviewed by State and Federal agencies. A number of these agencies have their own roles in the event of an emergency at San Onofre Nuclear Generating Station, including the U.S. Nuclear Regulatory Commission (NRC), the Federal Emergency Management Agency (FEMA), the State Office of Emergency Services (OES), and the California Highway Patrol (CHP). In addition, Dana Point is a member of the Interjurisdictional Planning Committee (IPC), a group of local agencies which meet regularly to coordinate their emergency procedures.

## **SCOPE AND CONTENT OF THE ELEMENT**

---

This Element is composed of two major sections: Public Safety Goals and Policies; and The Public Safety Plan. The Public Safety Goals and Policies section establishes public safety objectives and a decision-making framework for City leaders in evaluating issues for their safety impact. The Public Safety Plan provides more detailed recommendations for hazard mitigation and ensures adequate emergency response to identified hazards.

The Coastal Erosion Technical Report indicates that generalized building and grading codes and code enforcement do not necessarily keep pace with standards of prudent judgment applied by geotechnical professionals. According to this report geotechnical professionals believe that local grading codes tend to lag behind the current state of professional knowledge by five to ten years. Conformance to County grading codes or the most current Uniform Building Code is not necessarily adequate for mitigation of all coastal safety hazards.

The Coastal Erosion Technical Report provides detailed recommendations of potential mitigation measures for various segments of each subunit. This report also stresses the great variability in local geologic conditions, even on adjacent lots, and the resulting need to study each development proposal individually. Generalized mitigation measures for each subunit are discussed in the last section of this Public Safety Element, entitled The Public Safety Plan.

**Coastal Erosion:** There are two types of coastal erosion in Dana Point: the retreat of coastal bluffs and the loss of beach sands. Most beach sand comes either from sediment transport during river and stream runoff, or from erosion of coastal cliffs and bluffs. Because both of these processes have been impeded by urbanization, both in Dana Point and elsewhere, beach replenishment has been affected. Some portions of the Dana Point coastline have been more impacted than others, since impact is highly dependent on local factors, including beach configuration and location relative to manmade improvements, such as jetties and harbors.

**Blufftop Erosion:** Extending for approximately 6.7 miles, the Dana Point shoreline includes areas of sandy and rocky shore, coastal bluffs, and the rocky Dana Point Headlands. These areas have been subjected to continual erosion from oceanic, climatological, and developmental forces. Urbanization has accelerated the erosion process in many locations and created areas of instability.

The causes and effects of blufftop erosion along the Dana Point coastline were studied as a part of the Coastal Erosion Technical Report. The report findings, are described in detail in the Master Environmental Assessment and the Public Safety Element Technical Report. These background reports have shaped the Public Safety Element's erosion control goals and policies and are summarized below. The Public Safety Plan identifies preliminary specific erosion protection measures for each coastal subunit.

Development and construction tends to increase runoff and erosion. Damming of rivers has reduced the contribution of sediment to the ocean, resulting in narrowing beaches and increasing wave erosion of



sea cliffs. Blufftop activities, including construction of storm drains, fences, access stairways, removal of ground cover, oversteepening, overloading, and both accidental and intentional releases of water along the bluff face and into the bluff itself, have all increased erosion or failure.

Construction of residences along the blufftops in Capistrano Bluffs, Dana Cove, southern Niguel Shores and Monarch Bay has accelerated the erosion and retreat of blufftop properties and weakened major zones of bedrock, which can fail during large storms. This occurs particularly in residential areas where drought-resistant landscaping is lacking, where structures are set too close to the existing bluff edge, or where drainage runs toward the ocean. Seepage accumulation fosters large bluff failures even in nonstorm years.

Construction of residential paved areas along otherwise erodible blufftops inland from recreational beach zones such as Niguel Shores significantly reduces sediment contribution to pocket beaches which, unlike long straight sand beaches, are not easily replenished from littoral drift.

Construction of the Dana Point Harbor breakwater has caused a southward shift in longshore current transport of sand to areas downcoast of Doheny State Beach/Capistrano Beach subunit, and San Clemente Beach areas. Flood control channelization of San Juan Creek has reduced the natural river sand supply to Doheny State Beach.

The placement of dredge fills from Dana Point Harbor, or sandy export materials from inland grading operations, has historically minimized beach erosion conditions in the Capistrano Beach/Doheny Beach subunit. However, dredge sediment from the Harbor is currently considered unusable because it is contaminated above Environmental Protection Agency (EPA) and California Environmental Quality Act (CEQA) standards, due to the quality of stormwater runoff (Zeiser Report). Unless the quality of this sediment can be quickly improved, it is not a readily available source of sandfill for beach nourishment.

### **Seismic Hazards**

Dana Point, like the rest of southern California, is located in a seismically active area. No known active faults cross the City. The nearest significant active fault is the Newport-Inglewood Zone, located approximately four miles to the southwest. Figure PS-2 shows the location of this and other major active and potentially active faults in

relation to Dana Point. Major active faults which could affect Dana Point include the Whittier-Elsinore Fault, the San Andreas Fault, the Palos Verdes Fault, the San Clemente Fault and the Rose Canyon Fault.

Because no known active faults cross the City, the potential for surface rupture is believed to be limited. Ground shaking, liquefaction, landslides and rockfalls along coastal bluffs are the primary hazards which would affect Dana Point in case of earthquake.

Tsunamis and seiche, or seismic wave actions, are discussed in the Flood Hazards section. Policies described above which are designed to mitigate bluff erosion effects will also protect against seismically induced landslides and rockfalls.

Buildings that provide for public gathering with large concentrations of people should have increased design standards for protection from seismic hazards. The Modified Mercalli intensity scale as shown on Table PS-1 provides a description of the potential effect of varying levels of earthquake activity. Corresponding Richter Scale intensities are also shown on the table.

Two major types of seismic hazards are evident: ground shaking and liquefaction:

**Ground Shaking:** The extent of damage within Dana Point from earthquake-induced ground shaking will depend on the epicenter of the quake, its magnitude, and the characteristics of underlying earth materials. The maximum quake likely to occur along the Newport-Inglewood Fault is smaller than on other, more distant faults. However, because of its proximity, it poses the greatest potential for ground shaking damage to Dana Point. The maximum projected magnitude from an earthquake from this fault is 7.0 on the Richter Scale. A 7.0 magnitude quake along the Newport-Inglewood Fault would result in considerable damage even to specially-designed structures. Buildings would

Figure PS-2

be structurally damaged and underground pipes would be broken.

**Liquefaction:** During liquefaction, water-saturated sandy soils mix with shallow groundwater, causing soils to behave essentially like a liquid and to develop a consistency similar to quicksand. These soils lose their ability to support any structures. As a result, buildings constructed on such soils usually collapse. The most recent example of liquefaction damage occurred in the Marina District of San Francisco during the October 1989 earthquake.

Five areas have been identified as having potential for liquefaction: the floodplain deposits along San Juan Creek, Doheny Village commercial area, beach sands along Beach Road in the Doheny State Beach area, portions of the Palisades Drive, Coast Highway commercial areas, and the Dana Point Harbor area. These areas are depicted in Figure PS-2 as artificial fill and undifferentiated alluvium.

**GOAL 1: Reduce the risk to the community from geologic hazards including bluff instability, seismic hazards and coastal erosion.**

### **Geologic Hazards**

**Policy 1.1:** Require review of soil and geologic conditions by a State-Licensed Engineering Geologist under contract to the City, to determine stability prior to the approval of development where appropriate. (Coastal Act/30250, 30253) See comment 3

**Policy 1.2:** Monitor and document known and potential geologic hazards in the City.

**Policy 1.3:** Adopt standards and requirements for grading and construction to mitigate the potential for bluff failure and seismic hazards.

**Policy 1.4:** Provide for structural setbacks from the bluff top edges based upon recommendations by a State-Licensed Engineering Geologist. See comment 4

**Policy 1.5:** Adopt blufftop setback requirements based upon the severity of the conditions. The minimum 25-foot blufftop structural setbacks mandated by the Coastal Act may be inadequate. See comment 5

**Policy 1.6:** Prevent future development or revitalization of bluff top properties that may pose a hazard to owners, occupants, property, and the general public. See comment 6

**Policy 1.7:** Preserve Dana Point's bluffs as a natural resource and avoid risk to life and property through responsible and sensitive bluff top development. See comment 7

**Policy 1.8:** Encourage development which utilizes the desirable existing features of land such as natural vegetation, geologic features, and other features which preserve the site's significant identity.  
See comment 8

**Policy 1.9:** New bluff top development should be designed and located so as to ensure geological stability and to eliminate erosion, or destruction of the site or surrounding area. See comment 9

**Policy 1.10:** Bluff repair and erosion control measures such as retaining walls and other similar devices should be limited to those necessary to repair damage to the bluff face and should avoid causing significant alteration to the natural character of the bluffs.  
See comment 10

**Coastal Erosion** See comment 11

**Policy 1.11:** Design coastal protection devices that account for the factors exceeding the limits of previously recorded storms, elevated storm surges and spring tide conditions.

**Policy 1.12:** Specifically review and limit development on lands with seismic, slide, liquefaction, fire or topographic constraints. See comment 12

**Policy 1.13:** Encourage a periodic sand nourishment program to replenish, widen and stabilize the beaches where necessary.

**Policy 1.14:** Consider the establishment of Geologic Hazard Abatement Districts to encourage local cooperation in preventing coastal hazards and to access State, local, and Federal subsidies where appropriate.

**Policy 1.15:** Construct sea walls only as a last resort protective device for coastal areas.

**Policy 1.16:** Investigate means to improve the quality of Dana Point Harbor dredge sediment so that it can be used in sand replenishment programs.

**Policy 1.17:** Support and encourage the efforts of the Orange County Flood Control District to modify the San Juan Creek Channel in order to increase sediment yield to the Capistrano and Doheny Beach areas.

**Policy 1.18:** If dredge sediment from Dana Point Harbor cannot be made usable in the immediate future, support and assist Capistrano

watercourse within the floodplain.

In conjunction with the flood insurance program, flood-prone areas of Dana Point have been delineated on federally-prepared Flood Insurance Rate Maps (FIRMs). Much of the national flood insurance program is based on definition of the 100-year flood. The size of the 100-year flood is established based on examination of historical records. It is the largest flood that could be expected to occur once within a 100 year period. A 100-year flood would cover the total area of a designated floodplain. The FIRM maps also identify areas subject to a 500-year flood. These areas, however, are not subject to the same land use limitations as areas within the 100-year flood.

There are three Federal Emergency Management Agency (FEMA) floodplains designated within Dana Point. These floodplains are shown on Figure PS-3, which is adapted from FIRM maps. FIRM maps should be consulted for more detailed information. The primary floodway is San Juan Creek. Secondary floodways are Salt Creek and Prima Deshecha Canada.

San Juan Creek is the watercourse which poses the greatest flood hazard to Dana Point. The San Juan Creek floodplain varies in width from 700 feet to 1,200 feet. Although San Juan Creek has a concrete channel through the City of San Juan Capistrano, according to the Army Corps of Engineers the channel through Dana Point cannot contain the volume of runoff water generated by a 100-year storm. An eastward extension of the floodplain around Victoria Boulevard is created due to the potential for overflow from the underground Capistrano Beach Storm Drain. This eastward extension covers much of the Doheny Village area, which is largely developed. Many residents and businesses in this area would be at risk of water damage in the event of a 100-year storm. Actions may be taken to minimize damage through improvements to properties.

Salt Creek is a narrow watercourse running through the Links at Monarch Beach golf course. The 100-year floodplain of Salt Creek is approximately 100 feet wide and extends only as far south as Pacific Coast Highway. Salt Creek is fed by Arroyo Salada, which runs just a short distance through the City to the northwest of Salt Creek, just below Camino del Avion. The Arroyo Salada 100-year floodplain is approximately 75 feet wide. See comment 13

Prima Deshecha Canada runs through the City for approximately 200 feet, forming the City's southernmost border adjacent to Camino Capistrano. The stream is confined to a channelized spillway, which is designed to accommodate 100-year flood volumes.

C

C

C

# CITY OF DANA POINT URBAN DESIGN ELEMENT

## COMMENTS

1. Contrary to the approach taken by the developer, the project must be evaluated not as an overbuilt commercial island, but as to its interrelation with the concepts and open spaces of the entire community and particularly Monarch Beach and the Salt Creek Scenic Corridor.
2. The project neither improves the image, character and quality of life of the City, nor relates to the physical form of Monarch Beach.
3. A proper design for the site would be setback, as done in the last phases of construction and expansion on the site, from the bluff top and construction at the existing elevations. Attempting to hide the oversized structures from view from the west results in destroying the bluff, adversely affecting the rest of the Monarch Beach community.
4. The developers have no sense of place. Nowhere in the MND did they show an indication of reading the controlling Dana Point planning documents, let alone an understanding of the applicable and appropriate planning concepts. Monarch Beach is a community centered on the Salt Creek Basin Scenic Corridor. The project sits on a bluff at the western edge of the basin with significant impacts on the entire basin, including all of the residential areas across the basin, as well as the Monarch Beach Resort, now the St. Regis.
5. The project will satisfy all of the design and community conflicts if the developers maintain all existing ground elevations and step backs to the existing eastern building line. Rather than bringing the overall quality of Dana Point up to the quality of its best parts, this project takes one of the best parts and diminishes it to the back side of a commercial zone.
6. From the vantage of Salt Creek Trail, the project ignores the focus points and the mandate to improve them.
7. The old sanctuary is an architecturally significant church within Monarch Beach and with its iconic slanted roof should be preserved *in situ*.
8. An integral, if sometimes ignored, part of Salt Creek Beach Park is the Salt Creek

Trail along Salt Creek, extending from the ocean to Laguna Niguel alongside the eastern boundary of the proposed project.

9. Ocean view, ocean access, salt air, outdoor living all will be diminished throughout Monarch Beach at least for the planned ten-year (or longer) build out. The noise factor will continue forever.

10. We only want this project to enhance the Monarch Beach–Dana Point quality of life, not destroy it.

11. The developer has no appreciation for the natural assets of the community.

11A. One of the city's most significant view corridors is from Camino del Avion across the Salt Creek Trail and the Monarch Links Golf Course to the ocean, with Catalina in the distance. This view will be severely impacted by the construction of retaining walls, play grounds, and buildings on the bluff slope. Imagine a football field filled to a depth of 60 feet with dirt and you understand the intrusion into the view. This amount of dirt will be added incrementally with various phases to result in this effect.

The other significant view corridor is between the sanctuary and the Monarch Bay Villas, which will be destroyed.

12. By excavating the bluff top, the project will destroy mature historic vegetation on the slope and ridge. Mature stands of trees currently shield the view of buildings on the site. These will all be removed for construction of the new buildings.

13. The Salt Creek Basin is the heart and backbone of Monarch Beach, totally ignored by the developer. Mass grading and large, engineered flat pads proposed by the developer, more suitable for an industrial site, will destroy Monarch Beach's character.



---

## INTRODUCTION TO THE URBAN DESIGN ELEMENT

---

Urban Design is a process that builds on the foundation of the land use element. Urban Design focuses more precisely on the form and character of the natural and built environment; what we experience and how we feel about it. At its best, the process of Urban Design should persuade the City, private enterprise and the public to work together to create a community whose quality and living potential take full advantage of Dana Point's spectacular coastal setting, landscape, climate and cultural assets. See comment 1

---

## PURPOSE OF THE URBAN DESIGN ELEMENT

---

The Urban Design Element provides proposals and policies to improve the image, character and quality of life of the City. Although this element is not mandatory, urban design is important to the City because it relates directly to the physical form and character of development resulting from implementations of the Land Use, Circulation and Conservation/Open Space Elements. See comment 2

---

## SCOPE AND CONTENT OF THE ELEMENT

---

The Urban Design Element provides policies and design concepts for the preservation of the natural setting, public improvements, form and character of new private development, and focused plans for areas of the City in need of special design attention. See comment 3

---

## ELEMENT ORGANIZATION

---

The Element first presents Dana Point's important Urban Design issues, followed by broad Goals and definitive City Policies related to each issue. These are cross-referenced with relevant goals and policies of other General Plan Elements in Table UD-2.

The Urban Design Plan provides concepts to illustrate how the goals and policies may be implemented. The Plan is divided into two sections, the first containing citywide Urban Design concepts. This is followed by design concepts for three specific areas of the City. Appendix A of the Urban Design Element provides standards for landscape corridors in Dana Point. Appendix B provides the selected tree species for the landscape corridors. Both Urban Design Element appendices are included in the General Plan Appendix.

## **DESIGN GUIDELINES**

---

In addition to the Urban Design Element, Design Guidelines for the City contain specific design standards for public and private projects subject to discretionary design review. The Design Guidelines are adopted as a separate document from the General Plan. The Design Guidelines are to be used by property owners, developers, architects, landscape architects and designers in the planning of new projects and major renovations in the City. The Guidelines communicate the qualities and characteristics expected of development in the City. They are intended to promote higher quality design that is sensitive to Dana Point's natural setting, surrounding environment and community design goals. The Guidelines are used by City Council, Commissions, and City Staff as adopted criteria for the review of development proposals subject to discretionary design review. See comment 4

---

## URBAN DESIGN GOALS AND POLICIES

---

The goals and supporting policies relating to Urban Design establish the overall framework for the concepts discussed in the Urban Design Plan. These goals and policies address specific issues and opportunities that will enable the community to develop in accordance with highest design quality possible.

---

### CITYWIDE VISUAL LINKAGES

---

Dana Point's public beaches, parks, coastal lookouts and scenic attractions form one of the most spectacular collections of public open space in Southern California. Most of the City's residential neighborhoods are of similar quality and character.

Dana Point's overall image needs to be brought up to the quality of its best parts. Clearer positive visual and circulation linkages between the City's resources are needed, especially along primary streets. This can be accomplished by focused landscape, graphic, lighting and public art improvements in high-visibility places. See comment 5

**GOAL 1: Create Citywide visual linkages and symbols to strengthen Dana Point's identity as a city.**

**Policy 1.1:** Develop citywide linkages through landscaping and lighting along major street corridors. (Coastal Act/30251)

**Policy 1.2:** Improve the visual character of major street corridors.

**Policy 1.3:** Make focused improvements at major City entrance points such as landscaped open space and signage.

**Policy 1.4:** Preserve public views from streets and public places. (Coastal Act/30251)

**Policy 1.5:** Develop the Blufftop Trail from Monarch Beach to Doheny State Park. Final designation of the trail alignment through the Headlands shall be determined through the Specific

of each community.

**Policy 2.3:** Improve public places and recreational facilities as focus points for each community. (Coastal Act/30213) See comment 6

**Policy 2.4:** Establish a program to preserve buildings and sites of historical and architectural significance. See comment 7

**Policy 2.5:** Encourage neighborhood street landscaping programs to improve the quality of public spaces in residential areas.

## **THE DANA POINT TOWN CENTER**

---

At the present time, the Town Center does not have an environment or image that draws residents or visitors, nor does the Town Center work well as a "shopping district" where businesses benefit each other from an overall collective strength. Instead, the Town Center functions and feels like a roadside or "strip commercial" environment with many small separate commercial buildings and shopping centers that are poorly linked. The Pacific Coast Highway - Del Prado couplet, accompanied by high traffic speeds, has contributed to this problem. The small parcel sizes, lack of consistent site design patterns, diversity of building types and setbacks, and barren quality of the streetscapes are intensify the problems. There are some examples, however, that provide potential ideas for the future. The Plaza works well as a focus and pleasant pedestrian space - more environments like this can be created in the Town Center. San Juan Avenue presents a significant opportunity to create this additional pedestrian focus.

The future of the traffic system will be fundamental to developing site planning and building design guidelines that integrate the area. A major investment in public amenities (street trees, wider sidewalks, parking and side street improvements) will be necessary to transform the area's image and create stronger linkages between the blocks.

**GOAL 3: Improve the Town Center as one of the City's primary shopping districts with a small town "village" atmosphere.**

**Policy 3.1:** Increase the Town Center's economic vitality and its contribution to the City's economic development goals.

**Policy 3.2:** Reduce the disruptive and negative impact of traffic movements and high traffic speeds in the Town Center.

**Policy 3.3:** Improve pedestrian opportunities and create an attractive pedestrian environment within the Town Center. (Coastal Act/30250)

**Policy 3.4:** Encourage mixed-use development in selected areas of the Town Center.

**Policy 3.5:** Develop a parking concept that emphasizes shared parking facilities.

**Policy 3.6:** Create safety buffers of street trees, planters and street furniture between pedestrian walks and the street along both Pacific Coast Highway and Del Prado. Provide widened sidewalks with a special Town Center streetscape design.

**Policy 3.7:** Develop pedestrian courtyards and other outdoor spaces with planting and street furniture.

**Policy 3.8:** Encourage pedestrian-oriented building frontages with shops opening to the public sidewalk, and encourage a minimum amount of retail uses on the first floor.

## **PUBLIC SPACES**

---

A wide variety of recreational and scenic opportunities are available to the public along the City's 6-1/2-mile coastline. Except for a few key locations, public access to the water's edge is excellent. Public places on the coast include Doheny State Beach, Capistrano Beach Park, Dana Point Harbor, Dana Strand Beach and Salt Creek Beach Park. See comment 8

A unique sequence of parks and lookouts on the coastal terrace above the water offer spectacular views of the ocean and Dana Point Headlands. Pines Park, Gazebo Park, Leyton Park, Lantern Bay Park, Heritage Park, Blue Lantern Overlook and Salt Creek Beach Park are an extraordinary collection of public viewing and recreational settings. The "Blufftop Trail" from

the Headlands to Doheny State Beach is an excellent concept which appears to be successfully taking shape. Future development of remaining coastal sites, especially the Headlands, raises many issues of public access and presents opportunities for additional public open space.

**GOAL 4: Maintain and enhance the City's public spaces and resources.**

**Policy 4.1:** Create a new Civic Center as a focus point of the City.

**Policy 4.2:** Realize the opportunity for public open space throughout the City.

**Policy 4.3:** Develop stronger pedestrian, bicycle and visual linkages between public spaces and to and along the shoreline and bluffs. (Coastal Act/30210, 30212)

**Policy 4.4:** Encourage development of community cultural and recreational facilities. (Coastal Act/30213)

**Policy 4.5:** Protect and enhance existing public views to the ocean through open space designations and innovative design techniques. (Coastal Act/30251)

**Policy 4.6:** Preserve and maintain existing public accessways, and existing areas open to the public, located within visitor-serving developments in the coastal zone. (Coastal Act/30210, 30212)

**Policy 4.7:** Prohibit the conversion to exclusively private use of existing visitor-serving developments open to the public within the coastal zone. (Coastal Act/30210, 30213) See comment 9

## **DESIGN QUALITY**

---

Dana Point's commercial districts need stronger design coordination, improved circulation linkages, enhanced outdoor pedestrian spaces and higher-quality architecture that creates more attractive settings for shopping, entertainment and public gathering.

**GOAL 5: Achieve design excellence in site planning, architecture, landscape architecture and signage in new**

**development and modifications to existing development.**

**Policy 5.1:** Adopt comprehensive Design Guidelines for the review of all new non-residential and multi-family development in the City.

**Policy 5.2:** Encourage site and building design that takes advantage of the City's excellent climate to maximize indoor-outdoor spatial relationships. (Coastal Act/30250)

**Policy 5.3:** Encourage buildings and exterior spaces that are carefully-scaled to human size and pedestrian activity.

**Policy 5.4:** Encourage outdoor pedestrian spaces, sidewalks and usable open space in all new development.

**Policy 5.5:** Promote extensive landscaping in all new projects while emphasizing the use of drought-tolerant plant materials.

**Policy 5.6:** Encourage aesthetic roof treatment as an important architectural design feature.

**Policy 5.7:** Consolidate adjacent parking lots, without reducing the number of parking stalls, in order to decrease the number of ingress and egress points onto arterials. (Coastal Act/30210, 30252) See comment 10

**DOHENY VILLAGE**

---

Doheny Village has an excellent strategic location at the Interstate 5 entrance to Dana Point. Opportunities for commercial, office and light industrial businesses can help the City work toward its economic development goals. The self-contained mixed-use nature of the village, combining multi-family housing with small businesses, is also a unique quality that can attract future investment and improvements.

**GOAL 6: Develop Doheny Village as a unified and improved neighborhood of retail shopping, light industrial, offices and multi-family components.**

**Policy 6.1:** Improve Pacific Coast Highway and Doheny Park Road as aesthetic entrance boulevards to the City.

---

## THE URBAN DESIGN PLAN

---

The Urban Design Plan consists of two major sections. The first section addresses City-wide Urban Design concepts. This includes the primary elements that contribute to the design character of the City as a whole. The second section focuses on community design concepts for the Capistrano Beach, Dana Point, and Monarch Beach portions of the City. The Urban Design Plan concepts illustrate how the goals and policies can be applied to specific areas of the City. The figures and illustrations are indicative of concepts only, and are not intended (or interpreted) to establish a specific standard or requirement.

---

### CITYWIDE URBAN DESIGN CONCEPTS

---

#### **The Natural Setting**

Dana Point's spectacular natural setting forms one of the most memorable arrangements of sea and landform in Southern California. Its geographical location is marked by the "Headlands" and coastal bluffs. The Headlands is one of the most prominent features of the Southern California coastline between Point Loma and the Palos Verdes Peninsula. The City's favorable southwestern aspect orients toward Capistrano Bight, a subtle bend in the coastline which defines a shallow bay between Dana Point and San Mateo Point to the south. Santa Catalina Island is prominent as a scenic landmark visible on the open ocean to the west.

Dana Point and its southern neighbor of San Clemente both derive their community identities from their coastal locations, although each City's development history has interpreted the coastal setting in different ways. Dana Point, from its early history as the harbor for Mission San Juan Capistrano and visit by Richard Henry Dana, has emphasized its maritime identity as a place to engage the sea.



The landforms of the Headlands and coastal bluffs are the most prominent natural features of the City. They are visible from the region's coastline and coastal hillsides from a distance of up to 30 miles. Public views and pedestrian access to the bluffs are significant urban design and public resources of the City.

Urban Design policies and concepts guiding development of the Headlands are:

- Minimize alteration of existing topography of the Headlands to measures necessary for public safety and to accommodate a development program consistent with the General Plan and Headlands Specific Plan.
- Require setbacks of buildings and site improvements from the bluff faces which will assure public and structural safety, consistent with detailed geotechnical report recommendations.
- Encourage building forms that maintain a low profile and are visually integrated with the landforms.
- The significance of and treatment of existing ridges, knolls, canyons and vegetation on the Headlands and bluffs should be determined in the Headlands Specific Plan, EIR, and

URBAN DESIGN ELEMENT

JUNE 27, 1995

(GPA95-02(c)/LCPA95-08)

Resource Management Plan documents.

- Require all private development and public improvement proposals which have potential to impact public views of the Headlands and bluffs to submit detailed studies of view impacts. All development along the City's coastline, as well as several locations in the Dana Point Town Center and Monarch Beach areas, have potential to affect public views of the Headlands and bluffs.

## The Beaches

### Salt Creek Beach

Dana Point's coastline is unique in the diversity of its beaches. Capistrano Beach, Doheny State Beach, Dana Strand Beach and Salt Creek Beach each have a distinct character formed by surf conditions, orientation, views, landform background and access pattern. Capistrano Beach, Doheny State Beach and Salt Creek Beach are all publicly owned facilities operated by State or County agencies. Dana Strand Beach is a privately owned property. Most of the beaches enjoy wide strands that provide excellent public access along the water's edge. Urban design policies and concepts guiding development along the beachfront are:

- Require future built improvements adjacent to the beaches to consider the natural topography of the coastal terraces, embankments and bluffs as an integral part of the beachfront natural and visual setting. Development should protect existing natural features and be carefully integrated with landforms, emphasizing low profile building forms, retaining walls and other improvements that do not detract from the

natural setting of the beach.

- Some older insensitive beachfront development has marred the natural setting and blocked public views to the ocean. Future improvements or modification of previously-developed sites should strive to restore the appearance of the natural setting and open additional public views to the water. Opportunities to restore the appearance include:

Sensitive development of the old Mobile Home Park above Dana Strand Beach according to a Specific Plan for the Dana Point Headlands.

Encourage opening selective views to the ocean from the Pacific Coast Highway.

### **San Juan Creek and Salt Creek Basins**

San Juan Creek and Salt Creek divide Dana Point's land mass into three components which nearly concur with the communities of Capistrano Beach, Dana Point and Monarch Beach. The creek basins and intervening ridgelines give physical definition to the communities. The creek basins form visual corridors to and from the inland landscape of hillsides and ridges.

San Juan Creek's history is closely linked to Mission San Juan Capistrano. Historically, the creek provided irrigation for the farmland around the Mission and a trail to the small harbor. Although the flood control channel destroyed the natural appearance of the creekbed, the hiking/biking path to San Juan Capistrano is an important recreational resource. Urban design policies and concepts guiding development near the creek basins are:

- Future development of the land between the San Juan Creek channel and Santa Fe tracks shall provide an open space corridor for hiking and biking along the east channel edge. The corridor should be landscaped primarily with native riparian vegetation.
- Salt Creek and its surrounding basin has retained its open space character by location of The Links at Monarch Beach and adjacent Salt Creek regional open space, hiking and biking trail. Site planning, architecture and landscaping for the proposed Monarch Beach Resort development should

contribute to the open, spacious feel of the valley.  
See comment 11

### **The Capistrano Beach Palisades**

Most of Capistrano Beach lies on a coastal terrace rising to approximately 200 feet above sea level at the Interstate 5 Freeway. The bold line of cliffs (Palisades) along Pacific Coast Highway define the character of the beachfront and create exceptional views of the water from the residential neighborhoods on the terrace. Major issues in the area are erosion and stability of the bluffs, preservation of views of the bluffs from Pacific Coast Highway through the new developments on the inland side of the highway, and public views from the bluff top to the coast. Urban design policies and concepts guiding development along the Capistrano Beach Palisades are:

- New developments on the inland side of Pacific Coast Highway should preserve occasional open spaces to view the bluffs, avoiding a solid building line against the bluffs.
- There is potential for selective revegetation with native species on some of the bluffs and in the finger canyons along the Palisades. However, no further development or alteration of landforms should occur in the canyons.

## **Visual Linkages and Identity**

**Strengthen Dana Point's identity as a City by creating strong visual linkages with unifying design elements on major street corridors.**

Potential visual linkage. Planting on The Pacific  
Coast Highway, Monarch Beach

Dana Point's image, character and identity are highly dependent upon the design quality of its streets. The City's streets are the most visible part of the public environment, experienced daily by all residents and visitors who move about the City. The street system provides public spaces for walking and biking, scenic opportunities, and visual-symbolic linkages between open spaces, public facilities, neighborhoods and shopping districts.

Many of Dana Point's streets offer spectacular panoramic views toward the ocean. These view opportunities form an important part of the City's coastal identity, and are important scenic resources to be preserved. See comment 11A

Improvement of the City's street character requires the implementation of several design related elements including:

- Street trees and landscape "focus areas" along important thoroughfares.
- Improved pedestrian and bicycle opportunities connecting public parks, recreational facilities, scenic attractions, schools, residential neighborhoods and commercial districts.
- City identity graphics with directional signage marking public places.
- City entrance markers.
- Pedestrian-oriented lighting in special locations and districts.
- Preservation of public view corridors.
- Design guidelines for private property development to promote a coherent design character while allowing flexibility to encourage creative efforts.

## **Walking and Biking Linkages**

**Improve walking and biking opportunities between public parks, community facilities and scenic attractions throughout the City.**

Heritage Park. Pedestrian and Biking Linkage to Doheny State Beach

Dana Point's parks, open spaces, beaches and scenic lookouts are among the finest in Southern California. They need to be more clearly linked, physically and perceptually, to encourage pedestrian and biking circulation, and less use of the automobile.

The Blufftop Trail, which will eventually connect the Dana Point Headlands to Doheny State Beach, is an excellent example of the desired concept.

In addition to completion of the City's bikeway system, more pedestrian walks and trails need to be developed, and the pedestrian environment improved in key locations. Opportu-

URBAN DESIGN ELEMENT

JUNE 27, 1995

(GPA95-02(c)/LCPA95-08)



nities for pedestrian improvements include:

- Complete the trail from the Dana Point Headlands to Doheny State Beach, and extend the trail northward along Dana Strand Beach to Salt Creek Beach Park and the regional trail system along the Salt Creek Basin.
- Develop an open space corridor with landscape and recreational improvements along the east edge of the San Juan Creek Channel.
- Develop a special graphic signage system to locate and increase awareness of pedestrian and biking paths, including "scenic walks" and "scenic bike rides" throughout the City.
- Improve pedestrian opportunities throughout the City, by completing the "Landscape Corridors" program and adding special streetscape improvements to the Dana Point Town Center and Doheny Village districts.

Street trees, wide sidewalks, street furniture, pedestrian lighting, buildings and signage oriented to the sidewalk, and opportunities to stop at a park or other public place, are all essential to improve the City's pedestrian environment. Landscaping should be provided between the sidewalk and the roadway to protect pedestrians and buildings from traffic.

Historic Lantern Fixture  
Dana Point Town Center

- Develop pedestrian-oriented lighting on Doheny Park Road, between the Route 1 overpass and Camino Capistrano.
- Emphasize pedestrian-oriented site lighting in private development as a means to highlight pedestrian spaces and circulation patterns. Reduce high-masted site and parking lot lighting that contribute to excessive ambient light in the City's night-time sky.
- Develop pedestrian-oriented lighting adjacent to schools, community facilities and other public places with regular or occasional evening use.

**Public View Preservation**

**Preserve public views from streets and public spaces throughout the City, and open new views where opportunities exist.**

Street of the Golden Lantern  
View Corridor

The policy of the City is to protect public views when reviewing new development proposals and public improvement plans. However, the City does not accept responsibility for preserving

Dana Point enjoys an architectural diversity which reflects the stylistic preferences and predominant building types which have evolved over its 75-year built history. The City's earliest buildings were simple vernacular fishing shacks and shelters built along the coastline. The earliest permanent buildings were residences designed in a variety of styles, including the Spanish Colonial Revival, which became popular in California during the 1920's.

The City's communities each share common design elements that provide a subtle continuity to their architecture and landscape:

Capistrano Beach has no single architectural style, but the dense plantings and residential scale of the neighborhood present an informal character that emphasizes buildings carefully set in the landscape. The area's most successfully designed commercial buildings, such as the Edgewater Inn on the Pacific Coast Highway, continue this residential, informal feel.

The Dana Point Town Center's recent effort to establish an architectural theme has brought some continuity to the area, but architectural style in itself is not enough to accomplish the desired pedestrian orientation and "village" character. Design principles for the orientation of buildings to public sidewalks, provision of landscaped courtyards and other outdoor pedestrian spaces, removal of private parking lots from public view, and the scaling of building elements to human size are needed to build a more unified Town Center that attracts residents and visitors.

Monarch Beach has a more Mediterranean character of architecture and landscape. The area's spacious character and lack of mature vegetation make single building forms more prominent in the landscape. As the area's planting matures, the image will be increasingly dominated by vegetation. See comment 12

Architecture in Dana Point should emphasize the following basic principles, regardless of location or building function:

- The integration of buildings and outdoor spaces for pedestrian activity is encouraged. The use of courtyards, patios, terraces, balconies, verandas, covered walkways and other defined outdoor spaces for human activity can help provide a rich architectural character that takes advantage of the region's climate, is energy efficient, and is designed for maximum human use.

- Architecture, landscape design and site planning should contribute to the quality and character of the City's streets and public spaces. Each development should be carefully designed to benefit the character of the surrounding neighborhood and form a complementary relationship to neighboring buildings.
- Buildings, planting and site design should promote pedestrian activity and pedestrian emphasis whenever an opportunity exists. Building frontages at the public sidewalk should be designed to maximize pedestrian emphasis and de-emphasize automobile orientation.
- Larger buildings should be designed to reduce their perceived height and bulk by dividing their mass into smaller parts carefully scaled to human size.
- Building forms and elevations should create interesting roof silhouettes, strong patterns of shade and shadow, and integral architectural detail.
- Building signage should be carefully integrated with the site design, architecture, and plantings.

## **Historic Preservation**

## Monarch Beach

### The Ritz Carlton at Monarch Beach

Monarch Beach has a dramatic setting focused on the Pacific Ocean and Salt Creek Basin. The area has benefitted by master planning and more current development standards. Salt Creek Beach Park, Dana Strand Beach and The Links at Monarch Beach give the community an outdoor recreation emphasis. The most prominent landmark is the Ritz Carlton Resort Hotel, soon to be accompanied by the Monarch Beach Resort.

Monarch Beach has few Urban Design issues due to its newness and quality of recent planning efforts. Planned Urban Design improvements are:

- Completion of the Salt Creek regional trail from Laguna Niguel to Salt Creek Beach. Construction of a public beach building at Salt Creek Beach.
- Stronger development standards that provide carefully-sited and designed projects that fit the existing topography, minimizing mass-grading and large engineered flat pads.  
See comment 13
- Completion of roadside landscaping, walkways and bike paths along Pacific Coast Highway.
- Provide public improvements to Sea Terrace Park.

C

C

C

# MONARCH BEACH RESORT FINAL SPECIFIC PLAN

## COMMENTS

1. Each of the special conditions herein described for the Monarch Beach Resort (now the St. Regis) is, under the Dana Point General Plan, equally applicable to the adjoining sites, including the project site. The project site has all of the same environmental considerations, natural land forms and landslides, surface run-off and storm water drainage, aesthetics, and parking considerations as the Monarch Beach Resort. The project bluff frames the eastern boundary of the Salt Creek Basin, the Salt Creek Scenic Corridor and the Monarch Beach Resort. The project site is visible from all parts of Monarch Beach Resort and therefore impacts all of the careful considerations undertaken to create the Monarch Beach Resort Specific Plan. All surface water, storm water and ground water from the project site drain into the Salt Creek Basin and less than one-half mile away, the Pacific Ocean.

One must ask the question: Why would the City require one developer to consider the implications of his project on adjacent areas and not require it of another, especially if its bluff top location increases the impact on the same areas?

2. While this plan is specific to the property known as the St. Regis, it is integrated with and establishes rules equally applicable to the proposed development on the steeper than 2:1 slope adjoining and framing the Salt Creek Basin and Corridor, a 2:1 slope bluff that rises from the Specific Plan Area to the development site.

3. The proposed project will provide non-revenue competition to many of the revenue-producing businesses in Monarch Beach.

4. Clearly a plan focused on the specific resort parcel has geographic limits described by that parcel. Similarly, the developer must be held to the same parallel standard for the abutting bluff top parcel under consideration today.

5. The Specific Plan contemplates consideration of all of the neighboring communities.

6. And so too must this developer's parcel be treated consistent with the General Plan and the equally applicable concepts articulated in the Monarch Beach Resort Plan.

7. The developer has so far totally ignored impacts on the Salt Creek Basin and the surrounding communities. Each and every adverse impact must be identified and

mitigated. The fact that the developer designed a project and facility too large for the site and the community does not mitigate any of the adverse impacts.

8. It's all about an integrated, consistent community plan. Runoff from the project will adversely impact Salt Creek and the new storm-water runoff treatment plant, overpowering it, and shutting it down, resulting in additional continuous closures of Salt Creek Beach, diminishing the value of the St. Regis Beach Club and revenue to the City.

9. The developer has not used net acreage and ignores the fact that more than 20% of their total acreage is consumed by Crown Valley Parkway and the slope.

10. Because the developer ignored everything to the east it has ignored the existing trail system, which will be adversely affected by this project. The Salt Creek Trail is currently not navigable after moderate rains when dirt, silt and debris are washed from the bluff and block the trail.

11. The same standards applied to the St. Regis should also be applied to this project. The current facilities on the project site have inadequate parking. The developer intends to usurp coastal access parking at the Strands beach parking lot for its non-coastal access purposes – specifically to protect its revenue during the ten-year construction phases. The developer also intends to complete all of its revenue-generating facilities and only then, if they have the money eight to ten years later, construct additional inadequate parking facilities.

12. As the project is within 500 feet of a public beach access trail, the project should provide unlimited free surfer and beach parking.

13. The developer proposes destruction of all natural land forms on the east side of the property.

14. The developer proposes grading the Salt Creek Scenic Corridor out of existence in clear violation of each and every mandate herein.

15. The developer gives no consideration to building mass.

16. All the effort to enhance the Coastal Sage Scrub habitat will be destroyed by the project as currently conceived.

17. The South Coast Water District, run by affiliates of the developer, has assured the developer that he can have all the water he wants, while water for the rest of the residents



and businesses is rationed and restricted. Even with the direct line to the water district, the developer intends to suppress less than fifty percent of the dust generated by the project.

18. The developer and owner should not receive special consideration because of its relationship with the SCWD.

19. The developer-owner does not comply with existing minimal storm water control requirements.

20. To avoid mitigation methods that will show the developers are incapable of building an oversized project on an undersized site, the developers chose to ignore all impacts to the east by declaring the east an undeveloped wilderness.

21. Rationally, and in view of the already excessive parking load of the existing facility, the parking structure should be constructed first and above grade. The Monarch Beach Resort, a facility 40 to 100 times the size of this project, recognized the appropriateness of phases over a five-year period, not the ten years requested by this project developer.

22. Current economic conditions have made CitiBank the owner of the St. Regis. Three major Baptist facilities in the immediate vicinity are in serious financial condition, terminating services and selling facilities. This developer, for ten years, has been unable to raise adequate funding even for the first phase. If allowed to proceed on the current requested scale, the resulting facilities will provide non-revenue, non-taxable competition to the St. Regis and the other tax-paying facilities of Monarch Beach and Dana Point. The EIR should contain the same line-by-line analysis of this project as contained in the Monarch Beach Resort Plan starting at page B-7.

23. If you do not include parking in the numerator of FAR, it should also be excluded from the denominator. In Dana Point, it's defined as being exclusive of parking.

24. Is this project's facility to be open to the public for free beach parking?

25. Vehicular impact from the project during and after construction will be severe.

26. Note the five-year development policy.

27. This project does not conform to the aesthetic character of the neighborhood.

28. However, it is applicable to the adjoining bluff top project.

29. The existing site is not adequate for the expanded facilities.
30. The non-taxed SSBC facility will compete with tax revenue-generating facilities.



*MONARCH  
BEACH  
RESORT*

*Final  
Specific Plan*

*Amended September 1997*

*February 1992  
City of Dana Point,  
California*

2/11  
000300

DANA POINT PLANS

## 1.0 INTRODUCTION See comment 1

### 1.1 Executive Summary

The Monarch Beach Resort Specific Plan ("Specific Plan") contains the policies, programs, guidelines and development standards to guide development of this premiere coastal property. This Specific Plan has been prepared in compliance with the goals and policies established in the Dana Point General Plan. The development standards are intended to provide zoning for this project site.

#### Project Description

The Specific Plan area covers approximately 225 acres in coastal Southern California, within the City of Dana Point. The Specific Plan provides the framework for construction of a five-Star resort hotel and spa, up to 238 single-family detached and single-family attached residential units, expansion of the existing golf course, golf clubhouse, beach house, community park and an extensive public trail network (See Exhibit 1.1 following this page). See comment 2

#### Project Benefits

The benefits of this project, provided herein, include the following:

- Increased revenues to the City; See comment 3
- First class resort to enhance the City's image as a destination resort;
- Variety of public recreation amenities;
- Balanced, integrated, and self-sustaining community; and
- The enhancement of indigenous wildlife habitat.

### 1.2 Purpose and Intent

The Dana Point General Plan establishes the basic framework for development of the Monarch Beach Resort Specific Plan area, through its goal, policies, plans, and programs. The purpose of the Specific Plan is three-fold: 1) to implement the General Plan policies through more detailed policies that provide the necessary direction; 2) to establish zoning standards applicable solely to this master-planned resort community; and 3) to serve as the Implementation Portion of the City of Dana Point certified local coastal program for the Specific Plan area by carrying out the Certified Land Use Plan policies contained under Goal 8 of the General Plan Land Use Element. The Specific Plan and its implementation procedures contain the programs, plans, guidelines and development standards necessary to comply with the City's General Plan and provide for the methodical development of the Specific Plan area. See comment 4

The Specific Plan is to be adopted by the Dana Point City Council through two legislative actions. Chapters 1.0 and 2.0 provide the policies statement through plans, programs and guidelines for evaluating detailed development plans and will be adopted by resolution; Chapter 3.0 provides the zoning standards and regulations for the Specific Plan area and will be adopted by ordinance. Amendments to any portion of the Specific plan shall constitute an amendment to the Implementation Portion of the City of Dana Point Certified Local Coastal Program and shall not become effective until effectively certified by the Coastal Commission.

### 1.3 Project Setting

#### 1.3.1 Location

The Specific Plan area is located on the coast, in the northerly portion of the City of Dana Point known as Monarch Beach. The site covers approximately 225 acres, the majority of which lies within the Coastal Zone. The site is generally bounded on the north by Caminodel Avion; residential development and community facilities on the east; Pacific Coast Highway and the shoreline on the south; and residential and community commercial development on the west. In addition, Niguel Road bisects the Specific Plan area and a portion of its eastern boundary (see Exhibit 1.2 following this page.)

#### 1.3.2 Setting

The Specific Plan area represents approximately 6% of the total acreage of the City of Dana Point. It is the single largest development project area remaining to be completed within the City. The property is owned by Monarch Bay Resort, Inc. ("developer"), a subsidiary of Nippon Shinpan, Co. Ltd.

The project site consists of gently undulating topography which was previously graded into large flat pads. Salt Creek, a USGS blue-line stream, runs through the site to the ocean, partially within a surface channel and partially within a culvert. The Salt Creek streambed was planted with non-native plant materials in connection with the original golf course construction. Along the western boundary of the property is a small parcel, consisting of approximately eight acres, part of which remains ungraded. About 3.4 acres of this parcel are partially covered with Coastal Sage Scrub, a native California plant community. The low-lying portions of the site, including the area surrounding Salt Creek and the parcels adjacent to the shoreline and on the north side of Niguel Road, have been developed as an 18-hole golf course -- the Links at Monarch Beach.

#### 1.3.3 Surrounding Land Uses

The majority of the surrounding residential land uses are adjacent to on-site areas designated for open space and recreation uses provided by the expanded golf course and Sea Terrace Community Park (see Exhibit 1.3, following this page). The Specific Plan is sensitive to and addresses the potential impacts of traffic, views and public access on the surrounding land uses.

See comment 5

### 1.4 Site History

The Specific Plan is the result of an ongoing joint planning effort between the City of Dana Point and the developer.

The General Plan land use intensities, together with the Specific Plan guidelines, considerably reduce the view impacts from neighboring communities in comparison to the previous approved projects for the Specific Plan area.

In July 1991, the City adopted its new General Plan which allows for the developer's proposed plan consisting of a 400-key, five-star hotel and spa, Golf Clubhouse, 238 residential units, expansion of the golf course and improvements to Sea Terrace Community Park, providing significant benefits to the City and surrounding community. The developer's plan shows a reduction in the height, massing, and ground coverage of the hotel, as well as traffic and density over what was previously approved by the County.

In June 1991, two agreements were finalized by the developer with respect to the land uses established for the project site within the Dana Point General Plan, and have been considered in the preparation of the Specific Plan. These include:

- An agreement between the Capistrano Bay Park and Recreation District, and Monarch Bay Resort, Inc. providing for improvements and maintenance to Sea Terrace Community Park.
- An agreement between the Laguna Niguel Community Services District and Monarch Bay Resort, Inc., regarding the construction of two ball fields within the City of Laguna Niguel.

#### **1.5 Enabling Legislation**

The Specific Plan is both a planning document and a regulatory document to implement the General Plan. The enabling legislation for the Specific Plan is Section 65507 of the California Government Code. The City of Dana Point authorized preparation of the Specific Plan on July 23, 1991 via Resolution No. 91-07-23-7. Chapter 9.33 of the draft City of Dana Point Municipal Code, also recognizes the role of specific plans for large scale planning, by allowing greater creativity and flexibility in design during implementation of the General Plan.

#### **1.6 California Environmental Quality Act (CEQA)**

The Specific Plan is being prepared in compliance with the California Environmental Quality Act (CEQA). As discussed in Section 1.4 Site History, several previous projects of greater intensity, for which EIR's were prepared for this site, were processed and certified by the County of Orange. In addition a Program EIR was recently prepared for the City's adopted General Plan. The General Plan EIR analyzed land use assumptions for the Monarch Beach Resort site that were more intense than those ultimately adopted in the General Plan for the Specific Plan area.

Extensive environmental analysis was completed previously; the proposed land use intensities for the Specific Plan are less than those in previously approved projects as well as the General Plan EIR. In addition, all environmental impacts, anticipated in conjunction with this Specific Plan, are mitigated through the Specific Plan and site plan design, therefore a Mitigated Negative Declaration (MND) has been prepared. The MND provides the necessary documentation to mitigate all impacts to levels of insignificance, as no findings of overriding consideration can be made in conjunction with an MND. All subsequent levels of site planning (e.g., site development plans, tentative tract maps, etc.) will be reviewed against the MND.

#### **1.7 Consistency with the General Plan**

The Monarch Beach Resort Specific Plan must be consistent with the Dana Point General Plan. Therefore, the Specific Plan provides the policy statement through plans, guidelines and programs to allow for the implementation of the Dana Point General Plan elements.

The City of Dana Point General Plan Land Use Plan designates the Monarch Beach Resort area as a Specific Plan area with uses that include Residential at 7-14 du/net ac (Res 7-14), Visitor Recreation Commercial (VRC) and Recreation/Open Space (R/OS). (See Exhibit 1.4 on the following page.) See comment 6

The Land Use Plan, Statistical Summary and guidelines allow for the following uses and intensity of use:

- 400-key Five-Star Resort Hotel and Spa (VRC);
- Up to a maximum of 238 Attached and Detached Dwelling Units (Res 7-14);
- Golf Clubhouse (VRC);
- Beach House (VRC);
- Expansion and Improvement of the Golf Course (VRC);
- Construction and Maintenance of Sea Terrace Community Park as a Passive Park (R/OS);
- Other Open Space Features (R/OS), including coastal sage scrub restoration/enhancement; and
- Comprehensive Trail System (R/OS).

A comparative analysis of the Specific Plan consistency with the General Plan policies is provided in Appendix B.

### 1.8 Review and Adoption Procedures

The Specific Plan provides policy direction and guidelines in Chapter 2.0 and development standards and regulations in Chapter 3.0.

Chapter 2.0 provides the policy direction through plans, guidelines and programs intended to guide development of the resort. Chapter 2.0 also provides the design theme, establishes the overall character of the project area, and delineates the land uses and design components necessary to form a cohesive, high quality resort community.

The Draft Specific Plan will be reviewed by the Dana Point Planning Commission in public hearings. The Commission will forward the Specific Plan together with its recommendations to the City Council. The City Council will consider the Planning Commission's recommendations and public comment and may approve the Specific Plan as presented or modified at its discretion. Should the City Council elect to approve the Specific Plan, conditions of approval may be attached as part of the decision. Chapters 1.0 and 2.0 are adopted by Resolution of the City Council. A final Specific Plan reflective of the Council's decision will be prepared and will be the basis for all future development decisions in the Specific Plan area.

The Planning Commission and the City Council will consider the Specific Plan in light of the associated environmental documentation. In order for the Council to determine that the MND is adequate it must make a finding that all identified impacts have been mitigated to levels of insignificance as defined by CEQA.

Chapter 3.0 provides zoning and development standards and establishes the permitted uses and associated development standards and regulations for the Specific Plan area. Terms used throughout the document are defined in Chapter 3.0 in the Definitions Section unless, their context herein, is indicated. The Specific Plan standards and regulations are equivalent to zoning and supersede the City's Zoning Ordinance, (except where otherwise noted in the Specific Plan) Chapter 3.0 is to be adopted by ordinance.

The Specific Plan will also serve as the Local Coastal Program Implementing Actions Program for the Monarch Beach Specific Plan area. The Coastal Commission has jurisdiction for issuing the Coastal Development Permit (CDP) in the Specific Plan area. The Specific Plan guides all subsequent levels (e.g. Site Development Plans and Tentative Tract Maps) of planning and they must be consistent with the Specific Plan.

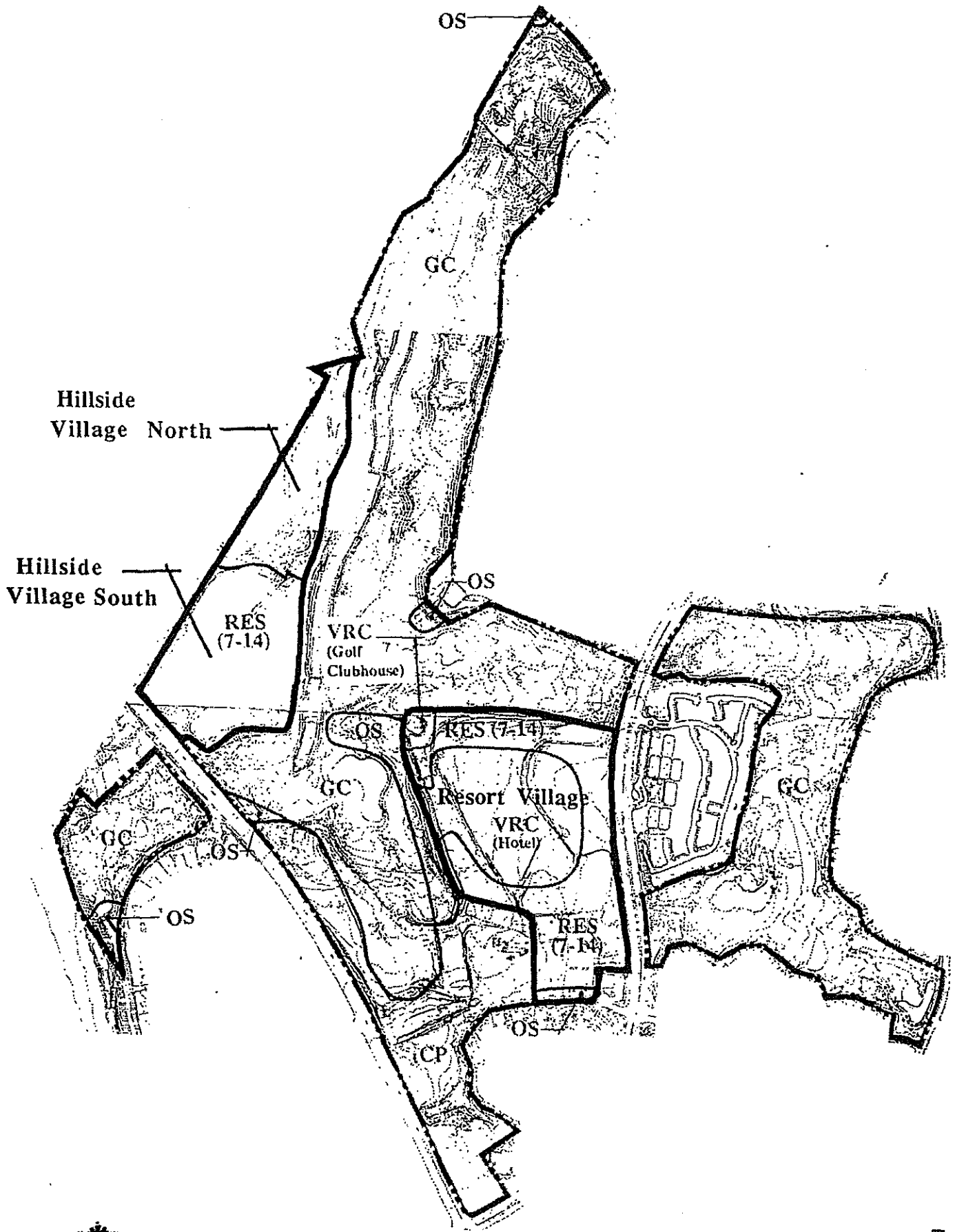

# VILLAGE CONCEPT PLAN

MONARCH BEACH RESORT  
SPECIFIC PLAN

2/11  
000319



Exhibit  
DANA POINT PLANS



## 2.0 PLANS, POLICIES, PROGRAMS AND GUIDELINES

### 2.1 Land Use Plan

The Land Use Plan, illustrated in Exhibit 2.1 following this page, designates the Monarch Beach Resort Specific Plan ("Specific Plan") uses which include residential, visitor recreation, commercial and recreation/open space, linked by a system of roadways and trails, all of which directly reflect the adopted Dana Point General Plan Land Use Plan. On the Land Use Plan each of the parcels having a specific land use designation is referred to as a "land use area". Those land use areas establish where development will be situated and, other than open space and recreation uses, are combined to create "villages". There are two villages in the Specific Plan area, the Hotel Village on the east side of the project site off of Niguel Road, and the Clubhouse Village on the west side off of Pacific Coast Highway. Both include residential uses in addition to the visitor recreation uses for which they are named. The beach house stands alone overlooking the shoreline and is referred to as the Beach House Site. (See Exhibit 2.2.) See comment 8

In subsequent levels of planning, the villages will be further broken down into enclaves. Each enclave will encompass a single use such as the hotel or a residential product. However, within any enclave there may be more than one residential product type.

Net acreage has been used to compute residential density. This has been calculated, based on the calculation defined in the City of Dana Point General Plan by determining the gross acreage of the land use areas within the project boundary and subtracting 20% for streets rights-of-way and other public lands. Minor adjustments to land use area boundaries may be necessary due to grading, road alignments, siting of structures, etc. These adjustments will be finalized when the Final Maps are prepared. Table 2.1 summarizes land use statistics by type and intensity. See comment 9

The developer will provide \$5.3 million in improvements to Sea Terrace Community Park. Of the total amount, \$4.06 million is the direct contribution by the developer. This is calculated by deducting \$1.24 million funds connected with the original dedication.

- Other Park and Open Space Features

A series of other park and open space features have been planned to link the resort grounds through a series of recreational experiences. These key open space and recreation features include:

- Botanical Gardens;
- Crescent Promenade;
- Vista Point Parks;
- Wild Flower Trail; and
- Park Accessway.

Trails, bikeways, and a for-fare resort vehicle system provide internal circulation, with coastal access and links to regional trails and public transportation.

- Trails

A network of pedestrian and bicycle trails link the community park to other park/open space features, as well as to the residential and visitor recreation commercial uses. The trails also link the resort with surrounding areas including the shoreline and inland areas. Trails are discussed further in Section 2.6 Public Access. See comment 10

## 2.2 Circulation

The Circulation Plan for the Monarch Beach Resort Specific Plan area illustrates vehicular, bicycle and resort vehicle systems (see Exhibit 2.7, following this page). This section describes the improvements to existing off-site roadways which provide access to the property, the improvements necessary to accommodate the project, and new on-site roadways.

### 2.2.1 Off-Site Roadways

The off-site roadways that provide access to the Specific Plan area: Pacific Coast Highway (PCH) and Niguel Road, which provide direct access; Crown Valley Parkway and Camino Del Avion, which provide access to the overall Monarch Beach area and indirect access to the project site.

- Pacific Coast Highway (PCH)

Improvements to PCH, contiguous with the Specific Plan area, include a signalized intersection where access to the Clubhouse Village intersects with the highway, together with the construction of an acceleration lane, a bus turnout and bus shelter near the corner of PCH and Niguel Road. The developer will be responsible for the costs of Pacific Coast Highway improvements as shown on Exhibit 2.8a from Niguel Road northerly to the northern boundary of the Specific Plan, subject to a nexus analysis.

distance of 125 feet per the current Caltrans Highway Design Manual, 4th Edition, Table 201.1. The stopping sight distance on a horizontal curve is measured from the inside lane. Using Figure 201.6 in the Highway Design Manual, the minimum distance from the centerline of the inside lane to sight obstruction (m) is 35 feet. Enhanced pavings will be used at selected areas to provide for the ambience of European villages. A pedestrian circulation system consisting of sidewalks or other alternative means providing adequate on-site pedestrian circulation shall be provided and approved as a part of the Site Development Permit.

### 2.2.3 Bikeways

The Specific Plan bikeway system will provide non-vehicular linkages as shown in Exhibit 2.26, the Bikeway cross-sections are shown in Exhibit 2.9, following this page. Bikeways and their integration within the other resort trails are discussed in Section 2.6 Access Program.

### 2.2.5 Resort Vehicle System

A for-fare public resort vehicle system is planned to link the hotel, golf clubhouse, and park within the resort community as well as the Salt Creek beach and parking lot. The fare will be modest to encourage public use. The operational plans of the resort vehicle system must be approved by the public agency having jurisdiction over the public trails (including Salt Creek Trail and the Pacific Coast Highway underpasses) which are part of the resort vehicle system's route, the City of Dana Point, and the Executive Director of the Coastal Commission. The inclusion of an alternative off-street transportation system linking the various sites in Monarch Beach has been included to improve coastal access (see Exhibit 2.26).

The resort vehicle system will originate at the resort hotel and travel to the clubhouse, Salt Creek Beach (by the existing beach access point between the Ritz Carlton hotel and the Ritz Cove residential community), Sea Terrace Community Park, and return to and terminate at the hotel. The resort vehicle system shall pick up and drop off passengers at the destinations identified above. The vehicle is proposed to utilize the Salt Creek and Beach Trails and the Coast Highway underpasses. Pathways will be striped, as required by the County of Orange, to insure that pedestrian and bicycle traffic will be separated from the resort vehicle traffic. If a beach house is constructed, it may be served by the resort vehicle system.

Priority may be given to hotel guests. All users of the resort vehicle system, including the general public, shall be allowed to carry with them beach gear. The resort vehicle system shall operate at sufficient intervals to meet demand by the general public. The resort vehicle system shall be operational concurrent with the commencement of operation of the Hotel.

### 2.2.6 Parking

A parking program has been developed for the Specific Plan area that is tailored to the integrated resort uses that are planned. The parking demand is being forecasted by analyzing the operation of each functional element of the five-Star hotel and spa in conjunction with the golf course and clubhouse usage. Parking requirements for the Specific Plan are based on the concept of shared use of parking between the Resort Hotel and the Golf Clubhouse and Course. The analysis and subsequent program is based on the results of field studies for various resort hotel operations for similar developments. Peak parking demand has been assumed when determining the number of parking spaces. See comment 11

Pursuant to the General Plan, shared parking will be provided to maximize the usage of parking areas between the Golf Course Clubhouse and the Hotel. There is adequate parking planned for all hotel guests and no hotel guests will be required to use shared parking. All parking spaces for the Hotel, Golf Course and Golf Clubhouse shall be available for use by the general public without obligation to use the Hotel, Golf Course and Golf Clubhouse

facilities. The hourly parking fee or total daily fee for general public use shall not be greater than that charged at the nearest State Beach Park parking facility. Validation stamps may be used for the parking facilities. Consistent with hotel operation requirements, the parking areas are anticipated to accommodate primarily valet parking though some limited self parking will be available. Tandem parking will be allowed in valet parking areas.

A residential parking program has been developed for the Specific Plan area. The parking program is being forecast on the type and quality of the project. Residential parking will be provided based on the parking standards established in Chapter 3.0. Residential parking will include double garages for each dwelling unit. In addition, on street parking, and parking in special bays shall be provided for guests. On-street parking shall be provided within the Specific Plan area for roads greater than 32 feet in width. Roads between 32 feet and 39 feet in width shall have parallel parking on one side. Roads 40 feet and over in width shall have parallel parking on both sides. Where on-street parking is located within 500 feet of a public trail access point, it shall be made available to the public. The final parking program will be defined during the Site Development Permit process and shall be consistent with this policy. See comment 12

### 2.3 Community Design Guidelines

In order to create a cohesive and integrated resort community, the Specific Plan provides for a framework of both development standards and the Community Guidelines outlined in this section. These guidelines are intended to provide subjective guidance in the definition of the grading, architecture and landscape architecture of the Specific Plan area. Although the development standards in Chapter 3.0 will serve as the zoning regulations for the Specific Plan area, these guidelines will provide the thematic and subjective design character for the project.

#### 2.3.1 Grading Guidelines

The Specific Plan is located in an area with predominately terraced topography consisting of relatively large flat pads created by previous grading activity. Existing natural landforms should be preserved to the extent possible. Modifications to existing natural landforms should be designed to blend in with and be consistent with the existing setting.

Finished grading should soften the harshness of large graded pads through the use of contour grading and site-adaptive structures. Contour grading should be employed at all daylight cuts, tops and toes of manufactured slopes, intersections of manufactured slopes and the interface between manufactured slopes and natural topography. Contouring should accomplish a rounding of manufactured edges and vary in slope to result in the appearance complimenting natural conditions. See comment 13

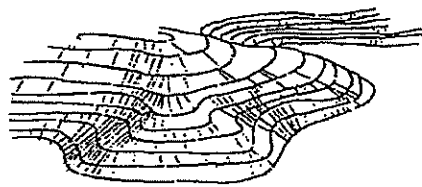

- Rounding of Manufactured Slopes and Varying Grades

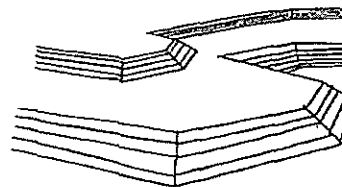

- Unnatural Cuts and Terrace Pads

Excavation and export from the site should be minimized. Rough excavation will result in excess dirt that will be exported to off-site locations. The balance of the materials will be used in the expansion and redesign of the golf course (see Exhibit 2.10, following this page). In addition to the above earthwork, a temporary borrow site, is planned to be located on the community park site, during construction. Material taken from the temporary borrow site will be replaced with other excavated material from other locations on the project site. The quantities needed for retaining walls, transition grading, corrective grading and similar conditions should be minimized and, where possible, the excess cut material should be reused within the development area.

In order to accommodate elevation changes across the site, the hotel site should be graded so as to gently slope downward from Niguel Road to the Golf Course.

Grading for the Clubhouse Village should respond to the environmental qualities of the site. The previously graded southern portion of the site should be regraded with contoured pads with a curvilinear road system reflective of the natural topography. The center area of the site should be graded as contoured slopes providing for construction of residential units directly upon the slopes. The northernmost end of the site should remain ungraded (except for any remedial alterations) and, to the extent possible, remain in a natural condition.

Grading for a beach house will be undertaken with due consideration of the geologic stability of the site and shall minimize the alteration of the bluff top and bluff face character, and ensure structural integrity.

Erosion control measures and efficient construction management will be employed at all times to minimize erosion and unmitigated landform damage. The existing vegetation on previously graded pads provides adequate erosion control and is maintained to City standard.

Downdrains and other surface flood control devices will be integrated into the contouring of the slopes to the maximum extent possible. Alternative engineering standards should be considered in highly visible locations to minimize the prominence of such improvements.

Any grading within or adjacent to the Salt Creek floodplain should minimize alteration of that corridor and its habitat. Any landform alteration within the corridor area resulting from grading or construction will be repaired and returned to a condition approximating the existing corridor condition to the maximum extent possible. Grading and construction vehicle use of Niguel Road and Mariner Drive will be minimized where feasible through the use of alternative routes. See comment 14

### 2.3.2 Architecture Guidelines

To give this project the special sense of place, the overall resort architectural theme will strive to capture the spirit and character of the Tuscan region of Italy.



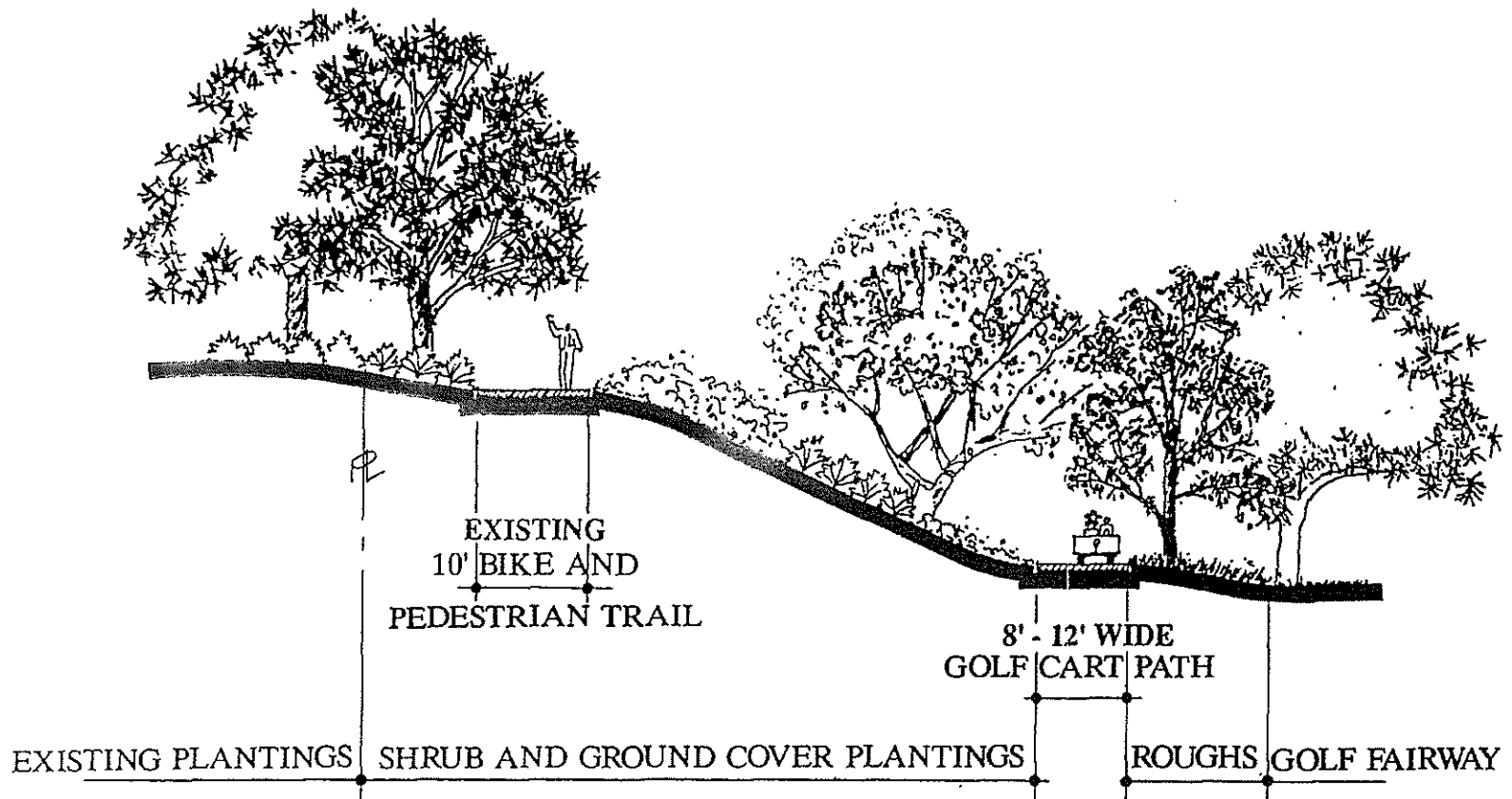

**SECTION 1 - UPPER SALT CREEK BIKE/PEDESTRIAN TRAIL**

(SEE EXHIBIT 2.16 FOR SECTION LOCATION)

NOTE: THESE LANDSCAPE PLANS ARE SCHEMATIC, EXCEPT FOR TRAILS THE DIMENSIONS VARY. THESE DIMENSIONS WILL BE MORE PRECISELY DETERMINED DURING SUBSEQUENT LEVELS OF PLANNING.



**SCHEMATIC LANDSCAPE CROSS-SECTIONS**

the apartments. Privacy for the apartments will thus be maintained. The maintenance facility, off of Mariner Drive adjacent to Sea Terrace Community Park parking lot will be fully screened with dense evergreen vegetation.

#### **Clubhouse Village**

The Clubhouse Village "hillside" landscape will be comprised of low spreading and medium sized trees, designed to emulate the Mediterranean coastal estates. Dense groupings of low and medium sized trees will screen the existing shopping center edge, and create a backdrop for the architectural elements in the Clubhouse Village.

#### **Salt Creek Canyon Transition Zone**

The Salt Creek Canyon Transition Zone will bridge the more refined landscapes of the Lower Golf Course and Clubhouse Village with the Native Coastal Zone seaward of Camino del Avion. The plant palette includes a mixture of native materials compatible to those of the Lower Golf Course, and include special planting groups forming a transition between the Salt Creek Corridor and the Native Coastal Zone. See Section 2.5 Resource Enhancement Program for additional detail and program requirements.

#### **Salt Creek Riparian Zone**

The Salt Creek Riparian Zone, which includes the creekbed itself, will remain in its existing state. However, a transition edge along the streambanks will be planted with compatible plant species to augment the naturalized plants in the creek channel and to create a wildlife habitat to the extent feasible consistent with golf and landscape requirements.

#### **Lower Golf Course and Park**

Located in the lower elevations of the resort community, this portion of the golf course and portions of Sea Terrace Community Park, will be planted almost entirely with low spreading theme trees, augmented by flowering accent and specimen trees. Lawn will carpet the ground plane, with slopes and accent areas covered in flowering shrub masses and ground covers.

#### **Upper Golf Course Edges**

The edges of the upper elevations of the golf course consists of groupings of low and medium trees, with accent groupings of narrow, vertical theme trees. The concept is designed to frame views from the nearby existing residential area.

#### **Upper Golf Course**

The Upper Golf Course palette includes groupings of low spreading and medium trees, and accent specimens in focal areas.

#### **Beach Golf Zone**

Incorporating varieties of plant materials associated directly with a shoreline environment, the Beach Golf Zone will be comprised of primary theme trees with accents of flowering specimens.

## Native Coastal Zone

The Native Coastal Zone, at the upper reaches of the Golf Course below Camino del Avion, provides a native landscape palette, including Coastal Sage Scrub species and Coast Live Oak, which provides habitat for wildlife. Along the perimeter of this landscape zone, small groupings of the primary landscape theme trees, such as pine and poplar, will provide transition from the Native Coastal Zone to the adjacent landscape zone. This program, re-establishing Coastal Sage Scrub, mitigates the loss of Coastal Sage Scrub on the slopes in the Clubhouse Village. (See Section 2.5 Resource Enhancement Program.)

## Resource Enhancement Program Compatibility

The resort's Landscape Design Guidelines incorporate the specific elements of the Resource Enhancement Program in the Native Coastal Zone. These program elements include the re-establishment of Coastal Sage Scrub habitat seaward of Camino del Avion, the provision of theme trees which provide wildlife and landscape value, with a compatible adjacent transition zone. These elements provide for enhanced wildlife value through the creation of native Coastal Sage Scrub habitat adjacent to the public open space preserve the Salt Creek Regional Corridor, that is located north of Camino del Avion. The Native Coastal Zone is approximately located in the drier, upper reaches of the Salt Creek Corridor within the resort.

### 2.3.4 Suggested Plant Palette

A suggested plant palette with a list of trees that are appropriate to establish the landscape character is provided below. The specific use and character of each species is highlighted. The plant palette provides examples and guidance for the development of the preliminary landscape plan required for the Site Development Permit.

TABLE 2.2  
SUGGESTED PLANT PALETTE

<u>Botanical Name</u>	<u>Common Name</u>	<u>Description</u>
<b>PRIMARY ZONE - HOTEL SITE</b>		
<b>PRIMARY TREE PALETTE</b>		
<i>Pinus Pinea</i>	Italian Stone Pine	Low Spreading Theme Tree
<i>Olea europaea</i>	Olive	Medium Sized Evergreen Theme Tree
<i>Erythrina caffra</i>	Coral Tree	Spreading Flowering Theme Accent
<i>Jacaranda acutifolia</i>	Jacaranda	Medium Flowering Accent
<b>SECONDARY TREE PALETTE</b>		
<i>Populus n. Italica</i>	Lombardy Poplar	Vertical Accent/Massing Theme Tree
<i>Pinus halepensis</i>	Aleppo Pine	Screening Tree
<i>Magnolia gradiflora</i>	Southern Magnolia	Tall Evergreen Character Trees
<i>Cupressus sempervirons</i>	Italian Cypress	Vertical Accent Theme Tree
<i>Macadamia integrifolia</i>	Macadamia	Low/Medium Character Tree
<b>ACCENTS AND SPECIAL USE TREE PALETTE</b>		
Citrus species	Citrus	Small Accents
<i>Ficus rubiginosa</i>	Rusty Leaf Fig	Low Spreading Character Specimens
<i>Eriobotrya japonica</i>	Loquat	Small Accent Tree
<i>Prunus blireiana</i>	Flowering Plum	Low Flowering/Foliage Accent



**TABLE 2.2  
SUGGESTED PLANT PALETTE  
(Continued)**

<u>Botanical Name</u>	<u>Common Name</u>	<u>Description</u>
<b>ACCENTS AND SPECIAL USE TREE PALETTE</b>		
Pinus torreyana	Torrey Pine	Beach Character Specimen
Prunus blireiana	Flowering Plum	Low Flowering/Foliage Accent
Cupressus macrocarpa	Monterrey Cypress	Medium Sized Character Specimens

**NATIVE COASTAL ZONE**

**PRIMARY TREE PALETTE**

Quercus agrifolia	Coast Live Oak
Mesic Aspect Coastal Sage spp.	

2.3.5 View Design Guidelines Concept

The architectural and landscape guidelines reflect a sensitivity toward existing public off-site views and for maximizing on-site views. (See Exhibits 2.17, 2.18, 2.19 a & b and 2.20)

Niguel Road is situated at approximately 175 feet above sea level. The proposed height of the hotel adjacent to Niguel Road will not exceed the 205 feet elevation line. The planned hotel overruns, for elevators, will not exceed 219 feet.

There are public views from existing roadways, which will not be impacted significantly by the development of the Specific Plan area. These include views from Niguel Road, PCH and Camino del Avion, that look across the existing golf course to the horizon line of the ocean. (See exhibits 2.19 A & B). Some of these views will be enhanced by development, as the golf course is being expanded and improved, and the existing graded pads will be replaced by development softened with extensive landscaping.

It should be noted that Niguel Road, which is designated by the City as a "scenic road", does not currently offer ocean views along the entire stretch of road adjacent to the project site, due to existing mature vegetation and off-site development. Nevertheless, location, massing and elevation of buildings within the Specific Plan area are designed to maintain public views from Niguel Road at controlled points (See exhibit 19). In addition, the future development of off-site residential property, located between the Pacific Ocean and PCH and adjacent to the golf course, will impact the existing view corridors from Niguel Road as well as PCH and Camino del Avion.

**See comment 15**

The Specific Plan also provides for public access to the resort grounds, community park, beach house, vista points in the park and other locations on the site, which will offer scenic views overlooking Salt Creek, the golf course, Salt Creek Beach and the Pacific Ocean.

The proposed development will have some impact on existing residential areas surrounding the site, however, most existing blue water views will be maintained. The one exception to this will be the condominiums across from the project site along Niguel Road, which will have a view of the hotel grounds and structures. Portions of their direct views of the ocean would be obstructed by the resort complex. The residential developer of these homes made buyers aware of the plans for development on the project site at the time of purchase.

Although the existing visual character of the site will be altered, the Specific Plan is endeavors to retain public views, where possible, from Niguel Road, Camino del Avion and PCH, by considering building setbacks, grade changes, building heights, etc., and would enhance public access to scenic views at the edge of the site through the development of Sea Terrace Community Park and a variety of open space features.

## 2.4 Parks and Open Space

### 2.4.1 Sea Terrace Community Park

This section discusses public park facilities including improvements, construction and maintenance of the 21.5-acre public park. Permitted and conditionally permitted uses for the Community Park are delineated in Chapter 3.0 Development Standards. The agreement signed June 1991, between the Capistrano Bay Parks and Recreation District (CBPRD) and Monarch Bay Resort, Inc. ("the developer") provides policy guidance and implementation procedures. Sea Terrace Community Park is located along the inland side of Pacific Coast Highway. The park is consistent with the General Plan and designated Recreation/Open Space in the Land Use Element of the General Plan. It is designated Community Park in the Specific Plan.

The park is bounded by the golf course, resort hotel, residential area and Pacific Coast Highway. Vehicular access will be from Mariner Drive. A major feature of the park is that it has a direct interface with the resort gardens, clubhouse, hotel and regional trail system. The resort grounds are an extension of the park. Persons visiting the park will be unaware as they cross the line between public and private ownership.

Planned park facilities include: an amphitheater, a park pavilion, signage and lighting, trails and benches, a maintenance building and equipment yard, parking and access, picnic and lawn areas, a par course, a tot lot, a vista point and extensive landscaping. (See Exhibit 2.21, following this page.)

The developer will construct the park and also provide on-going maintenance of the community park as if it were an extension of the resort community.

The park is designed as a Tuscan-style passive park with extensive landscaping and promenades linking with other areas of the resort.

The existing tunnel which runs under Pacific Coast Highway, known as the Niguel Shores underpass and connects the park with the Salt Creek Beach Park and beach parking, will be improved to City standards and will be open for public use. The CBPRD has agreed to improve and maintain the tunnel. The developer has agreed to light the underpass.

One at-grade parking lot will be provided with approximately 80 spaces available for the public using the park. About 40 spaces will be in a paved parking lot the other 40, which will service overflow parking, will be on turf block to minimize the visual impacts. Parking areas and the adjacent maintenance building will be screened with berms and landscaping.

### 2.4.2 Clubhouse and Golf Course

This section describes the development and operation of the golf clubhouse and the expansion and upgrading of the existing 18-hole golf course. The integration of the golf course with the other public open space amenities is also discussed.

Promenade. Will be lushly landscaped with botanical interpretive features to provide educational opportunities. The botanical garden will be constructed and maintained by the developer.

- Hotel Gardens

The hotel grounds will offer a series of garden settings to create the ambience of a grand country villa. The gardens including the Cascade Gardens, Olive Terrace and Orange Groves --will be constructed and maintained by the hotel operator. The gardens include the hotel entry, a series of gardens abutting the guest accommodations wings, and hotel courtyards.

- Residential Landscape

Common area gardens in the residential enclaves are an integral design component of the resort community. They will add to the overall visual continuity of the resort community by blending the private residential gardens with the public open space areas. The residential common area gardens will be constructed by the developer and maintained by the Homeowners' Association.

- Park Accessway

An accessway will provide a pedestrian walkway and bikeway as well as emergency access between Niguel Road at Stonehill Drive and Sea Terrace Community Park. Improvements to this area will include paving, landscaping, and lighting.

#### 2.4.4 Public Parkland Requirements

The Specific Plan provides for improvements and maintenance of the 21.5 acre Sea Terrace Community Park.

In conformance with the minimum park requirements under the State Quimby Act, up to three (3) acres of dedicated parkland for each 1,000 population, an equivalent amount of in-lieu fees, an equivalent amount of park improvements, or an appropriate combination of the above, shall be provided by the developer as "park requirements." This section defines the type of parkland to be dedicated within the Specific Plan area, in addition to procedures for implementing the park requirement.

The local park requirement for the Specific Plan area is based on the anticipated number of units and the average household size (number of persons per unit). The following table shows the calculation for determining the park requirement.

Table 2.3

Monarch Beach Resort Specific Plan Area

Persons Per Household Parkland Generation Rates\*

<u>Residential Units</u>	<u>Average Household Size</u>	<u>Total New Residents</u>	<u>Required Parkland Acreage</u> (3 ac./1,000 pop.)
238 DU	2.5 persons	595	1.6 Acres

\* Source: City of Dana Point

In 1983 a bond was posted which provided for \$1.24 million in improvements to Sea Terrace Community Park subsequently approved plans changed the character of the park plan as well as the term and conditions of the bond. In May and June 1991, two agreements were executed between the developer and CBPRD providing for an additional \$4.06 million in improvements to Sea Terrace Community Park, which, when added to the original bond allocation, total \$5.3 million in improvements. This includes the exchange of approximately 8 acres in Lot A, formerly a proposed public park area, to golf course use and approximately 5 acres of Sea Terrace Park to golf course for some of the improvements allocated to Sea Terrace Park by these agreements. The agreement also stipulates that the developer has agreed to provide on-going maintenance for the park.

These agreements also acknowledge that the developer will offer to dedicate and construct additional open space improvements to comply with the City's Park Requirement. Consistent with these, the developer has agreed to offer for dedication at least 4 acres of parkland distributed throughout the site, and to make improvements of at least \$1.35 million to these areas. The agreements also provide additional safe guards to the Park District for the development of these improvements.

Based on the Parkland Generation Rates shown in Table 2.2, the park requirement of 3 acres per 1,000 population is more than satisfied with the parkland dedication of the open space features. The addition of substantial improvements in the form of extensively landscaped vista points, the botanical gardens and promenades, along with continuous maintenance of the areas, more than satisfy the park requirement determined by the City's park and generation rates.

In the development of the Specific Plan, the City can require more parkland and improvements than is permissible under the Subdivision Map Act. Therefore, this Specific Plan provides for dedication and improvement of between four (4) and 4.7 acres of other park and open space features.

**2.5 Resource Enhancement Program**

The Resource Enhancement Program (REP) provides a comprehensive, multi-stage, two-phased program (Exhibits 2.24 following this page) to re-establish 6.7 acres of Coastal Sage Scrub (CSS) habitat within the Monarch Beach Resort where it can be appropriately maintained and monitored. The re-establishment of CSS on Lot A is intended to fully mitigate in advance for the loss of CSS on the Clubhouse Village parcel. (See Exhibits 2.22 and 2.23, following page II-20) See comment 16

In response to concerns from the community and resource organizations over the reduction of CSS habitat in southern California, the developer has committed to re-establishing and maintaining an improved CSS habitat area on-site in conjunction with the removal of topsoil and CSS shredded plant material from the Clubhouse Village slopes. Reuse of this topsoil and material using on-site genetic materials and soil types that are critical to the ultimate success of the reestablishment of CSS.

The selected site for the re-establishment of CSS habitat is known as Lot A. The Lot A area is contiguous with the upstream Salt Creek Regional Corridor open space by virtue of the Camino del Avion underpass. As such, enhancement of this site provides the opportunity to establish a wildlife corridor linkage between and along the Salt Creek Corridor and the resort. It also provides for the long-term maintenance and monitoring of CSS habitat. The location is consistent with the resort landscape plan and has been designed in concert with the expansion of the golf course. The site will be the southern terminus of the Salt Creek Corridor's CSS habitat zone that extends several miles upstream to Niguel Road in the City of Laguna Niguel. Numerous consulting biologists, independent biologists, state and federal agencies, and local environmental organizations have provided input into the design of this program.

Phase One of the enhancement plan consists of the initial restoration of 3.4 acres of CSS on Lot A in advance of development, with Phase 2 establishment of 3.3 acres of CSS occurring once certain performance standards have been met. Ongoing maintenance and monitoring accompany each phase.

The REP addresses the necessary program elements of a successful CSS restoration effort. These include: siting, preparation, use of on-site soil and plant materials, transition zones, maintenance and monitoring and phased implementation, which will function as dispersal and shelter for any remaining wildlife.

The Resource Enhancement Program provides habitat opportunities including:

- Create habitat diversity within the corridor;
- Provide eradication of invasive plant species;
- Provide CSS and California Gnatcatcher habitat;
- Integrate native species into the landscape plant palette;
- Provide habitat for a variety of species;
- Provide linkage to the Salt Creek Corridor;
- Provide wildlife movement corridor; food sources, nesting sites, roosting and perching locations;
- Provide ongoing maintenance and monitoring; and
- Create a unique environment for the golfer, resort visitor and trail user.
- Accomplishes a plan that the developer and environmental groups support.

These opportunities can be achieved by meeting the principal goal of the Resource Enhancement Program.

Goal: To provide and enhance native habitat for indigenous wildlife, especially the California gnatcatcher, within the Lot A area of the Salt Creek Corridor, to be maintained in perpetuity by the resort operator as Coastal Sage Scrub habitat. The new CSS habitat replaces an existing CSS area planned for development in the Specific Plan.

#### 2.5.1 Existing Natural Resource Conditions

The existing conditions of the natural resources of the site are important in determining appropriate actions related to preservation, enhancement potential and development opportunities. The following section describes the site conditions of the Lot A area and its immediately surrounding context.

- Site Conditions and Context

The REP will be implemented within the approximately 7-acre Lot A site plus additional acreage south of Lot A. The total CSS enhancement area exclusive of the golf course covers approximately 6.7 acres. Camino del Avion divides Lot A from upstream areas by a high bridge and embankment. Salt Creek has been diverted below ground through a culvert and daylights just seaward of Lot A.

The area selected for the restoration program has been disturbed. The site vegetation is dominated by ruderal (weedy) species, such as Russian Thistle (*Salsola australis*), Cardoon (*Cynara cardunculus*), and Mustard (*Brassica sp.*). Three areas of fill on the site are also vegetated with ruderal species. Patches of California Buckwheat (*Eriogonum fasciculatum*) exist along the roadway and trail embankment, apparently the result of a previous revegetation effort. However, it is sparsely distributed and mixed with non-indigenous species such as Desert Encelia (*Encelia californica*) and Sea Lavender (*Limonium perezii*). Irrigation and rain runoff from three culverts have allowed a small amount of vegetation to grow including a six-foot Willow (*Salix sp.*), ± 80 square feet of Cattails (*Typha sp.*) and two large Salt Bushes (*Atriplex sp.*).

- Impacts to Sensitive Resources

The Lot A area contains no sensitive plant or animal resources. No sensitive plant or vertebrate species were observed in Lot A during site surveys done in May and September 1991.

The Specific Plan in Phase I provides for the re-establishment of approximately 3.3 acres of existing Coastal Sage Scrub habitat located on the Clubhouse Village slopes. Much of this habitat is too dense for the California Gnatcatcher to utilize for nesting. The CSS habitat area remaining in this area is isolated and fragmented. Its size is generally considered below adequate quality to support a pair of breeding California Gnatcatchers. No birds were spotted during several site visits in September 1991. (A pair of gnatcatchers were spotted on the property in May, 1991.)

- Enhancement Program Elements

Elements of the REP were developed in consultation with several organizations including the South Coast Audubon Society, Gnatcatcher and Coastal Sage Scrub experts, U.S. Fish and Wildlife Service and California State Parks Department, and restoration experts. Project biologists and California Gnatcatcher habitat research also provided significant input to the program.

The REP elements feature the reuse of plant species (genotypes) and topsoil from the Clubhouse Village slopes. This technique will promote rapid CSS re-establishment. REP features include:

General Elements:

- Creating of Coastal Sage Scrub habitat, with small pockets of Coast Live Oak (refer to Exhibits 2.23, 2.24 a & b).
- Integration of the Habitat Enhancement Plan with expansion of the Links at Monarch Beach Golf Course and grading plan for Lot A.
- Implement the program through a phased approach utilizing on-site plant and soil materials (existing genotypes/gene pool) from the Clubhouse Village slopes to be relocated to the Lot A area to facilitate habitat establishment.

- Provide long-term maintenance and monitoring of the CSS habitat during establishment and after completion.
- Provide for potential wildlife movement between the lower and upper Salt Creek areas.
- Replicate California Gnatcatcher CSS habitat structure where possible.

#### 2.5.2 Resource Enhancement Program

- Coastal Sage Scrub (CSS)

The REP goal is to establish the ecological structure and function of the CSS community which could potentially support the California Gnatcatcher, along with a variety of other animal species.

Habitat Value: The CSS plant community offers abundant food sources, as well as cover, for many indigenous wildlife. The linkage of new CSS habitat at Monarch Beach Resort with existing CSS habitat in Salt Creek Regional Corridor will help to counter the effects of widespread habitat fragmentation, such as on the Clubhouse Village slopes, and isolation which have been shown to have severe consequences upon CSS-dependent species. Many typical CSS bird species live primarily close to the ground and do not fly high or long distances. Such species should use the proposed continuous band of CSS as well as the adjacent riparian habitat as a movement corridor. Proposed maintenance and monitoring of this connection will ensure long-term viability and health of the habitat.

Description: CSS is a drought resistant-deciduous shrubland plant community adapted to California's Mediterranean-type climate at elevations ranging from sea level to 3,000 feet above sea level. CSS habitat is generally between 1.5 and 7 feet tall. Many of these shrubs have foliage which exude pleasant aromas. In addition to low shrub species, taller open canopies of undisturbed CSS allow for an abundant component of herbaceous species including grasses and succulents. Clusters of compatible tree species may sometimes be used to add variety to large expanses of CSS species, where appropriate, in accordance with the MBRSP landscape guidelines.

#### Features of the Coastal Sage Scrub Enhancement Program:

- A portion of Clubhouse Village parcel topsoil ('A' soil horizon approximately 6" in depth) will be utilized in the restoration program. The soil will be stockpiled for reuse within the restoration and enhancement areas. Use of the topsoil and plant material from the Clubhouse Village slopes is absolutely critical to program success. The use of Clubhouse Village parcel topsoil will occur in two phases. In Phase I, in which 3.3 acres of CSS will be created, existing stockpiled topsoil and vegetation on the north portion of the Clubhouse Village (formerly site 16) will be utilized. In Phase II, additional topsoil and selected vegetation from both the previously disturbed area and the existing vegetation area will be used to complete the CSS establishment effort.
- Indigenous (local plant types whose genetic composition may include adaptations to their specific local environment) will be used for revegetation.
- Where noted above, selected CSS plant materials on the Clubhouse Village slopes will be transplanted, where feasible.
- Site preparation and an ongoing maintenance program will focus on eradication of common weed species such as Artichoke Thistle, Mustard and Russian Thistle or Tumbleweed within habitat areas.

Solanum douglasii  
Solanum xanti  
Stipa pulchra

Douglas' Nightshade  
Chaparral Nightshade  
Purple Needlegrass

Additional herbaceous species may occur in the Clubhouse Village slopes topsoil. If other indigenous CSS herbaceous species are known to occur in seed donor areas, these will be specified in the seed collection contract. Stipa lepida or Foothill Needlegrass, a CSS associate, will be added to the complement of site-native species.

CSS habitat is to be located on the outer slopes of the Lot A area. Larger contiguous areas will be planted as planned, principally on the eastern and northern slopes of the area. The larger areas are anticipated to be the most suitable for California Gnatcatcher due to their configuration and dimensions. Narrower CSS areas should function more as wildlife dispersion and foraging area.

CSS areas will also be interspersed with clusters of trees where appropriate, as defined in the landscape guidelines.

Mesic Aspect CSS Components - Due to sun angles, the slopes with north to northeast slope orientation are more protected from heat and desiccation (drying) than their south- and west-facing counterparts. This results in micro-environments which contain relatively more moisture than slopes with greater solar exposure. Intermittent drainage and seeps may also contribute to increased moisture-availability. Under such conditions, the species listed below will occur with greater frequency. Higher concentrations of seed of these species will be applied to areas with more northerly aspects to assist in species establishment. One area of mesic CSS habitat has been identified on a northwest facing drainage.

Species include:

<u>Botanical Name</u>	<u>Common Name</u>
<u>Isomeris arborea</u>	Bladderpod
<u>Malosma laurina</u>	Laurel Sumac
<u>Rhus integrifolia</u>	Lemonadeberry
<u>Rhamnus crocea</u>	Redberry
<u>Ribes speciosum</u>	Fuschia Flowering Gooseberry
<u>Sambucus mexicana</u>	Mexican Elderberry

- Integration of CSS With the Golf Course Expansion and Trails

The areas designated for CSS and establishment were determined in conjunction with several factors. These include grading plans for the Lot A area, the design of the golf course expansion, the location and gradient of cart paths and trails, and the vista point adjacent to the Camino Del Avion bridge. The goal is to maximize CSS habitat where feasible and to minimize turf area. The REP plan reflects all of these design considerations.

CSS habitat will be allowed to grow up to trail and cart path edges. Adjacent to Camino del Avion, the CSS vegetation will be maintained in a thinned state for fire safety purposes.

The irrigation of the golf course turf area will be controlled so as not to adversely impact the CSSxeric (drought tolerant) habitat which would not be regularly irrigated once established.



Fairway green and tree drainage/irrigation patterns and drainage systems will be designed to contain runoff within maintained golf course areas, so as not to impact adjacent CSS vegetation.

Around several of the golf tees, Stipa grassland with native wildflowers will be planted. The major components of this grassland are Needlegrasses. This association will be green during wetter months and will grow to about 2 feet in height. Flower spikes will appear in the spring. After flowering, the area can be mowed to encourage new growth in the fall. Autumn-blooming flowers would be added for seasonal color. CSS habitat will surround the Stipa grassland/wildflower area.

- Integration of CSS With the Resort Landscape Plan

The REP has considered the overall resort landscape theme in the location and selection of an important tree species, Coast Live Oak (*Quercus agrifolia*) having significant habitat value which has been conceptually located along perimeter edges and near Salt Creek.

Coast Live Oak, an evergreen tree, is useful for screening and habitat value including food, cover and nesting opportunities. CSS habitat will initially extend up to the trees trunks when they are young and retreat as tree canopies spread.

Transition zones between CSS habitat and the resort's ornamentally landscaped areas will also be provided. These zones will be planted with native or drought-tolerant plant materials as determined by the overall landscape plan. Care was taken not to create conditions that would over-irrigate these areas or allow runoff to impact CSS habitat.

- Wildlife Movement

Wildlife still remaining within the remnant CSS habitat on the Clubhouse Village slopes will be encouraged to move to both the remaining 0.8 acre of CSS habitat on the Clubhouse Village slopes and the Salt Creek riparian zone. Prior to grading, steps will be taken to allow wildlife to relocate to these other areas. This will be accomplished by an organized team walking abreast through the habitat area, creating disturbances to flush wildlife from the area to be impacted into new habitat areas.

- Transition to Salt Creek

CSS habitat would remain at the middle to upper slopes adjacent to Salt Creek allowing a transition zone to exist. A riparian zone currently exists within the creek bottom and lower slopes. The treatment of the creek area itself is dealt with under the landscape guidelines, Section 2.3.3. California Sycamore (*Platanus racemosa*) would be planted at the edge of CSS habitat and the Salt Creek channel. This would provide tree cover, roosting and nesting opportunities for various bird species found along the Salt Creek Corridor.

- Fuel Modification

Fuel modification zones are required by the Orange County Fire Department (OCFD) within zones where natural lands directly abut residential or other development. The REP area is bounded on the west by an apartment complex opposite the county bikeway and on the east (top of slope) by a single family residential development. Existing irrigated landscaping occurs on either side of the REP area.

CSS plant species are allowed under County fuel modification guidelines if properly spaced and maintained. A minimum buffer zone of 100 feet has been provided at the top of the eastern slope. Existing landscaping and the county bike trail form a buffer on the western side of the project. Specific

The Access Program includes an information component. The hotel will contain in a conspicuous location such as near the bell captain stand, concierge desk, or guest registration desk, a manned visitor information center, designed to orient the general public as well as hotel guests, as to the various uses available for public access and recreational use. Information shall also be made available through the use of brochures, maps and other guides showing the user all the locations, points of interest, and other public access and recreational opportunities within the resort and the surrounding area. The information center shall be fully functional concurrent with the commencement of operation of the Hotel.

The Access Program also includes a circulation system component. This system incorporates public, guest and private off-road circulation and integrates the bikeways, hiking trails, association accessways, paths, resort vehicle system, at least one public access bridge crossing over Salt Creek connecting the Salt Creek Trail with the Golf Clubhouse, and other components of non-vehicular circulation network. Each component is designed to function as a separate and dedicated route for one of the variety of off-road circulation uses.

Exhibit 2.26, following this page, depicts the Access and Trails Plan. The plan shows each circulation component with type designations for each segment. For example, the Public Regional (Salt Creek Corridor) Trail is designated as either "R-1" or "R-2" depending upon the characteristics of each respective portion of the trail.

This off-road circulation concept was prepared based on the Dana Point General Plan and input from the City, the public, public utility agencies, the Capistrano Bay Park and Recreation District (the "CBPRD") and the Orange County Harbors, Beaches and Parks Department ("HBP"). While primarily focusing on the on-site circulation and access, it also addresses key linkages to regional facilities (e.g. Salt Creek Regional Corridor and Salt Creek Regional Beach Park) and other public use areas beyond the boundaries of the project and City.

The Trails and Access Plan depicts the following general types of circulation components within and adjacent to the project, each of which is explained in greater detail below (see Exhibit 2.26, as well as the landscape cross-sections in Exhibits 2.11 a-k, following page 11):

- Public - On-Street Bikeway (Type "B-1")
- Public - On-Street Sidewalk (Type "W-1")
- Public - Regional Corridor (Types "R-1" & "R-2")
- Public - Public Off-road (Local) Bikeway (Type "B-2")
- Public - Public Local Walkway (Types "W-2" & "W-3")
- Public - Resort Vehicle (Types "T-1", "T-2" & "T-3")
- Public - Multipurpose Undercrossings (Types "U-1", "U-2", "U-3" & "U-4")
- Private - Association Accessway (Type "E-1")
- Private - Utility Agency Easement (Type "E-2")
- Private - Golf Car Paths (Type "G-1")
- Private - Services/Maintenance Driveway (Type "M-1")

#### 2.6.1 Public (Within R.O.W.) Bikeways (Type "B-1") and Sidewalks (Type "W-1")

Public sidewalks and Class I or Class II bikeways have already been completed along both sides of Niguel Road, Camino Del Avion, Stonehill Drive. Sidewalk improvements along Pacific Coast Highway will be installed concurrent with completion of the Sea Terrace Community Park along the park's highway frontage. The bikeways and walkways form the primary links to the public recreation resources outside of the Specific Plan area.

#### 2.6.2 Public Regional (Salt Creek Corridor) Trail (Types "R-1" & "R-2")

The Salt Creek Trail exists throughout the entire reach between Camino Del Avion and the Salt Creek Beach Park. The plan incorporates resort vehicle uses in portions of the trail (shown as Type "R-2") in the vicinity of the Hillside Village South through the Salt Creek underpass (Underpass "U-1"). Other aspects of the resort vehicle system are outlined below in the section entitled "Resort Vehicle System". Salt Creek Trail, which is located on the westerly side of Salt Creek, shall be connected to the Golf Clubhouse on the easterly side of Salt Creek via a Type "W-2" public off-road walkway, as shown on Exhibit 2.26.

#### 2.6.3 Public Off-road Bikeways (Type "B-2")

The Specific Plan provides for a system of pedestrian/bicycle routes through the area connecting Niguel Road (via Stonehill Drive) with Sea Terrace Community Park, Pacific Coast Highway, the Salt Creek Regional Beach Park and the Salt Creek Corridor trail (via Pacific Coast Highway sidewalk). The bikeway's point of connection to the Niguel Road regional bikeway is located at the end of the Stonehill Drive cul-de-sac near the County fire station. This location was selected to allow for a stronger trailhead entry statement for the on-site bikeway system and to avoid issues, which would be prevalent in the vicinity of the tunnel. These issues include safety conflicts with golf uses, difficult grade transitions, easement encumbrances, and bisection of the residential community and other physical constraints.

Each bikeway will be owned by the underlying landowner, but will be open to the general public by means of easements acceptable to the City and CBPRD. In addition to aesthetics and access criteria, safety of use was a significant factor considered in the siting and connections of the bikeways.

Bicycle racks or other appropriate storage devices will be provided at appropriate designated locations including transitions between bicycle and non-bicycle uses. This will not only be a convenience for the guest and user, but will also encourage bicycle usage by the public and employees, thereby having the secondary benefit of lessening automobile dependence and associated traffic and pollution impacts.

#### 2.6.4 Public Off-road Walkways (Type "W-2")

Due to physical constraints (e.g. gradient, barriers, etc.) and safety concerns, bicycle use on portions of the public accessways would not be appropriate. Consequently, a separate component of public pedestrians-only paths is provided in the plan. Bicycles, skateboards and other non-pedestrian uses will be prohibited. As with the bikeways, these walkways will be privately owned as a part of the property and open to the public by easement. At least one of these public walkways shall bridge Salt Creek and provide a safe, public connection between the Salt Creek Trail (Types "R-1" & "R-2") and the Golf Clubhouse.

These walkways will be comprised of stabilized decomposed granite material, which is similar to very coarse sand and includes tiny "bits" of granite stone. When used as a pathway or roadway material, it provides a stable surface with minimum maintenance. Stabilized decomposed granite is "stabilized" by adding an organic type of binding agent (or sometimes a soil-cement) to the decomposed granite material that essentially "glue" the particles together to become a more durable material. With proper compaction, it approaches the character of concrete in

Construction and operation of the resort vehicle system is contingent upon obtaining necessary approvals by the City, HBP, CalTrans and the California Coastal Commission. It will be necessary to obtain the requisite rights-of-way, permits and licenses prior to implementation of the resort vehicle system or construction of the Beach House. Given these requirements, the resort vehicle system may be modified by these public agencies to assure the most effective and safe public access system for the Specific Plan area. The City will cooperate and assist the developer in its attempts to obtain these necessary interjurisdictional approvals necessary to operate the resort vehicle system.

#### 2.6.7 Underpasses at Pacific Coast Highway and Niguel Road (Types "U-1", "U-2", "U-3" & "U-4")

All four underpasses are structurally complete.

Underpass "U-1" has been fully completed with all planned improvements. It is currently open to the public as a part of the Salt Creek Corridor trail easements. This underpass is jointly used by golf carts, golf course maintenance vehicles, utility vehicles, pedestrians and other uses allowed within the Salt Creek Corridor.

Underpass "U-2," known as the Niguel Shores underpass, is complete except for interior improvements (paving, lighting, finishes, etc.). The developer will install the paving and lighting in the underpass concurrent with the completion of the Sea Terrace Community Park. All other improvements and long-term maintenance of the underpass improvements will be the responsibility of the CBPRD. This underpass will also be jointly used by pedestrians, bicycles and the resort vehicle.

Due to safety conflicts with golf uses and other issues outlined above (see "Public Off-road Bikeways"), public uses of the underpass at Niguel Road near Stonehill Drive (Underpass "U-3") will be limited to only pedestrians to cross Niguel Road between the two public sidewalks along either side of Niguel Road. To complete this pedestrian connection, the existing walkway connection from the sidewalk on the east side of Niguel Road will be opened to the public and will be augmented by a similar public connection from the underpass to the sidewalk on the west side of Niguel Road. No connection will be made from the underpass to the trail system (except for the purposes of serving golf carts and other golf uses). Bicycles will also be prohibited within the underpass section due to limited clearances and safety concerns.

The northern Niguel Road underpass near Corniche Drive (Underpass "U-4") will be used only for golf related uses. Similarly, the paved pathway leading from the public sidewalk on the western side of Niguel Road near this underpass will be limited to golf course uses only as it only connects to existing golf paths.

#### 2.6.8 Private Association Easements (Type "E-1") & Utility Easements (Type "E-2")

Several third-party private ingress rights are integrated into the plan. These private association trails leading from the Monarch Bay Villas, the South Shores Baptist Church property, the Sea Terrace Apartments and the area known as Site 14 have been provided to allow residents of these neighboring locations direct access through the Specific Plan area property to the bikeway/walkway system.

A number of public utility easements are also included within the plan. Although not strictly a circulation route, they are referenced in the plan in order to clarify that these easements are for authorized use only by the public utility agencies which have beneficial rights in such easements.

#### 2.6.9 Golf Pathways (Type "G-1")

As with other non-public accessways outlined elsewhere herein, this pathway system is shown for reference only. Except where they coincide with public bikeways and walkways, golf pathways will be open only for golf related uses. Their precise location may be determined as a part of the golf course redesign. With the exception of the

### 2.6.13 Coastal Access Fund

Through fees paid in connection with various permits issued by the Coastal Commission, a Coastal Access Fund was created for the specific purpose of improving public access to coastal resources. Coastal access fees were imposed on a number of residential developments within the south Orange County Coastal Zone. Although administered by the Coastal Commission as pursuant to permit conditions, the access fund is currently under the custodial management of the California Coastal Conservancy.

The Coastal Commission and Coastal Conservancy have made the policy decision to assign and transfer a significant portion of the Coastal Access Fund to cities within the County for local use. Since a major portion of that fund was generated in Dana Point by development within the Specific Plan area, the City has indicated support for application of those funds to a program related to the Specific Plan area. This is discussed further in section 2.14.1 Financing of Public Facilities.

### 2.6.14 Restricted Uses

Due to the land use constraints and safety issues, certain kinds of activities on the trails would not be appropriate. Except as outlined above, private use by homeowners' associations and unauthorized guests or other third parties will be prohibited on all components except for public trails. Use of the various trails and accessways by vehicles, motorized cycles, golf carts, skateboards and similar vehicles other than those specifically authorized by code, easement, agreement or license will be prohibited. Specifically, no vehicle operated by, or on behalf of, any homeowner or homeowners' association will be allowed on public bikeways and walkways, the resort vehicle routes, Salt Creek Corridor trail, any underpass link, or golf path. These policies, where appropriate, have been developed in conjunction with the CBPRD, the HBP, and City of Dana Point.

## **2.7 Housing**

Pursuant to State law, the City of Dana Point has adopted a General Plan Housing Element which includes policies, programs and goals which address anticipated housing needs. The Housing Plan, which only has a 5-year time span (1989-1994), is prepared from a citywide and a coastal zone perspective. The City is in the process of implementing the housing policies in the General Plan in an effort to meet its goals. The Specific Plan for the project is consistent with the policies in the General Plan and does not preclude the City from implementing its 5-year plan.

A range of needs are considered by the Housing Element, including: residential rehabilitation; conservation of existing affordable housing; preservation of assisted housing at risk of conversion to market rate housing; special needs; overcrowding; cost burdens; and new housing production. The "need category" most pertinent to the Project is the demand and supply conditions regarding new housing production.

The Housing component of the Specific Plan provides an overview of the housing needs of the City for the five year period ending 1994 and determines what density categories of housing have been provided for in the General Plan Housing Element to meet these needs.

### 2.7.1 Share of Regional Housing Needs

The General Plan Housing Element includes a projected need of 1,000 new housing units during the five year time span of 1989 to 1994. Table 2.4 shows the five year regional housing growth by income category as reported in the adopted Housing Element. As indicated by Table 2.4, 41.4% of the "need," or 414 housing units, are projected in the very low and low income categories. Another 19.1% of the need, or 191 housing units, are for moderate income households.

element is located at the corner of Stonehill and Niguel Road to identify the entrance to the project trail system and Sea Terrace Park.

Within the Community Signage Monument for the Golf Course and Hillside Village, additional signage will identify and direct the residents, and the public, to the resort, Salt Creek and public trails, park, and open space areas, and the northern and southern portions of the Hillside Village residential areas. At the entrance to the road leading to the Golf Clubhouse there will be additional signage which will identify and direct residents, the general public and guests to the Golf Clubhouse, the hotel and the northern residential enclave of the Resort Village. Should the entrance road be relocated or additional entrance roads constructed, the additional signage shall be placed at the relocated or additional road(s). The signage shall inform the general public that the Golf Clubhouse facilities are open to the general public. The signage monuments shall be integrated into the project perimeter/security walls, or into the guardhouse structure set within the entrance roadway median.

The lettering for these signage elements is intended to be, either raised individual letters with vertical letter dimensions of no more than 12", or recessed plaques no larger than 48" in any dimension. Signage shall be positioned within 24" and 72" of finish grade.

- Key Directional Monuments:

At key internal street intersections, small signage monuments or plinths will direct residents and guests to their destinations. These signs will include groups of address identifications, or specific function or activity elements. The signage for these monuments will consist of verdi-gris finished raised lettering or plaques set into the construction elements. The lettering shall be no more than 10" high, and shall be positioned between 36" and 60" above finish grade.

- Informational Signage:

Throughout the Monarch Beach Resort Community, especially in Sea Terrace Park and in the public amenities, special signage will provide directions and information of general public interest. Maps will be used as a part of the informational signage to identify trail routes and public facilities. The signage elements will utilize either the monument character of the larger sign elements, or will utilize less ornate materials and detailing as warranted by intended use. Along with stone or plaster and/or rusticated wood members of sufficient dimension will be used for anchoring lettering or plaques. Overall signage or monument size shall not exceed 60" in height, and shall be of sufficient horizontal dimension to position the lettering or graphic presentations in proper proportion and spacing.

- Off-Road Circulation Signage:

Signage for each component of the off-road circulation sign system will provide information specific to each aspect of the circulation system as detailed in the access section of this chapter. Signs will include directions, location maps, trail types, prohibited uses, allowed uses, restrictions, hazard or caution warnings, user responsibilities, Golf Course routing, etc. As each element will differ in requirements of clarity and purpose, aesthetic scale and details will be influenced by each component's environmental setting. Each element will be designed to be compatible with the General Resort architectural elements and character. Public trailheads and accessways noted will be marked with signage meeting customary size and text standards, as well as graphic symbols for ease of understanding and compliance to applicable local codes.

- **Project Roadway Signs and Devices:**

Customary street signage and other graphic devices within the Monarch Beach Resort roadway system will be detailed to support the resort character. Dimensions and specific text or orientation requirements will adhere to the codes, ordinances, and policies of the Specific Plan or other City codes.

- **Public Roadway Signage:**

Any additional public roadway signage that may be required outside of the specific boundaries of the Monarch Beach Resort Community, but within public roadway rights-of-way, shall comply with the standards, codes, ordinances, and policies of the governing public agency.

- **Future Facility Signage:**

Future facility signs will be planned at appropriate locations within and surrounding the Specific Plan area. These signs will provide information such as project component identity, expected completion dates, contact and telephone number information for future key components of the resort such as the Resort Hotel, the Golf Clubhouse, the Sea Terrace Park and Beach House, residential developments, and the availability of public amenities in the future facilities. This signage character, although temporary in nature, will implicitly reflect the quality materials and fine detailing of the permanent signage monuments. No future facility sign shall exceed 96" in vertical dimension, nor 144" horizontally.

All signage shall be reviewed and approved as part of the final permitting process by the City of Dana Point for consistency with the Signage Implementation Plan, the special conditions of all valid coastal development permits approved for the Monarch Beach Resort, and the Monarch Beach Specific Plan. Prior to the City of Dana Point's assumption of Coastal Development Permitting authority over the Monarch Beach Resort area, all signage shall be reviewed and approved by the Executive Director of the Coastal Commission.

- **Construction Signs:**

Construction signs shall be posted at various appropriate locations within and surrounding a respective construction site. The signage will provide customary construction-related information such as project identity, owner, developer, architect, landscape architect, engineer, permit information, general information, contact information and telephone numbers, and similar information. Construction signage will be temporary, and provisions will be adopted to ensure timely removal upon completion of the respective construction.

The Construction signage will comply with the theme and character of the Resort development. Sign size and quality shall be appropriate for the location and specific purpose.

- **Other Signage:**

In keeping with the project theme and character, numerous secondary signage types will be utilized for sales, leasing, special events, permanent or temporary vehicular control, safety, and identification is consistent with the intent of this Signage Program.

## 2.10 Water Conservation

Increasing demands for urban water uses call for conservation and encouragement of reclaimed water use as important elements in the overall management of water resources. This is especially true during times of drought and water shortages such as those which the region has experienced during recent years.

See comment 17

Whether or not drought conditions continue or reoccur, sensible water utilization and conservation will be an integral part of the planning, design and efficient operation of the resort. The developer shall submit a water conservation plan to the South Coast Water District (SCWD) and receive approval of such plan prior to the issuance of building permits.

The water conservation measures summarized below will be provided by the developer.

#### 2.10.1 Routine and Ongoing Interior and Exterior Water Monitoring and Audit.

Monitoring of water usage by the hotel, clubhouse, and other components of the resort will be a regular part of the operational policy of resort operator. The hotel operator's attention to efficiency and cost savings customarily dictates such monitoring as a part of routine business operations. The operator will develop a program for ongoing review of water usage practices and will establish policies for periodic water usage audits to identify adjustments and other ways by which water can be conserved and more effectively used within the resort.

This program will be made an integral part of the operations policy of the resort. It will be developed by the hotel facility operator and will be available to the SCWD and the City, upon request.

The irrigation systems for the golf course and other landscaped areas will employ flow-monitoring devices to facilitate continuous monitoring of irrigation usage. This capability will minimize the likelihood of undetected leaks or abnormal irrigation practices.

#### 2.10.2 Compliance with Water District Requirements

The SCWD has adopted, and from time to time has amended, certain water-related ordinances relating to water efficiency and conservation. The developer will be obligated to comply with such ordinances and other policies of the SCWD. The SCWD will review the plans and specifications for compliance and may impose conditions on its approval as necessary to ensure such compliance. SCWD approval is required prior to City permit issuance or authorization to proceed with construction of the water and reclaimed water distribution system.

See comment 18

#### 2.10.3 Water Conservation Fee

The SCWD has established a Water Conservation Fee for development within the District. The purpose of this fee is to provide a fund by which water conservation programs of the district can be carried out. Such programs include public information and education, water conservation incentives, retrofitting of high-volume water fixtures and conservation-related research and planning.

The developer will pay the Water Conservation Fee to the Water District pursuant to the SCWD's then-current policy and rate schedule.

#### 2.10.4 Water-Saving Devices and Fixture Specifications

The operator will employ water-efficient devices and fixtures throughout the development. Although for health, safety and other reasons, certain uses may necessitate the use of standard devices, the Specific Plan residential communities will be constructed to low-flow and water-saving plumbing specifications in accordance with City building codes.



#### 2.10.8 Extension of Reclaimed Water Distribution Line

As outlined above, the master water plan of the SCWD calls for reclaimed water to serve the common areas within the Specific Plan area. Due to elevation and pressure constraints, use of gravity-fed reclaimed water is currently precluded at the upper reaches of the golf course. Consequently, reclaimed water is currently pumped to these locations from an existing pump station at a lower elevation in the golf course. Also, no reclaimed water service main lines are yet available directly to the adjacent Monarch Bluffs Apartment site and Lot A above the golf course below the Camino Del Avion bridge.

This situation results in several undesirable conditions. First, reliance upon pumping as a method of delivery is subject to interruption from equipment or power failure. There are also a number of costs and maintenance needs associated with the pumping facilities. Second, the lack of reclaimed water service to Lot A and the adjacent Monarch Bluffs necessitates the use of domestic potable water for all exterior irrigation. Under drought conditions, it is highly possible that this type of potable irrigation would be restricted or even prohibited by the governing water agencies.

The existing reclaimed water service main from the line in Santa Lucia Street in the adjacent development, will be extended to a point in Lot A immediately north of the golf course. Upon completion, this connection will allow use of gravity service of reclaimed water, and the pump station could then be deactivated. Lot A and the adjacent Monarch Bluffs will also be served by the extended reclaimed water system and use of potable water for irrigation of these areas will be discontinued.

Other reclaimed water connections which will be completed as a part of the Specific Plan implementation will further improved service by elimination of pumping facilities or increases in pressure at the point of discharge.

#### 2.10.9 Use of Recirculating Water in Landscape Features

A number of water features are currently planned for the Specific Plan area. All such features will have recirculating systems and will not utilize potable water except for evaporation replacement and, as may be necessary, for refilling after repairs.

Except for pools and ponds within the hotel complex itself, all water features (including ponds in the golf course) will utilize reclaimed water, subject to the approval of the health authorities. The golf course ponds currently use reclaimed water.

#### 2.10.10 Guest/Customer Information

As an integral part of its guest program, the operator will provide information on the need to conserve water. Patrons of the food and hotel components will be made aware of the area's water shortages (when applicable) and of the continuing need for conservation. To implement this program, the operator will utilize methods currently in use in other resort areas which have adopted similar water-efficient policies.

The information program will be developed by the hotel operator as a part of the operational policy and public relations implementation. The assistance of the South Coast County Water District will be encouraged, and the program will be made available to the SCWD and City for comment prior to implementation.

### 2.10.11 Employee Education

The resort's comprehensive employee policies and procedures will include information and policies for the various components of the resort's water conservation programs. As with other such policies, each employee will be expected to understand and keep informed of the resort's water conservation policy and to implement it to the extent possible within the employee's job duties.

### 2.10.12 Residential Restrictions

Covenants, Conditions and Restrictions, commonly known as "CC&Rs", will be developed and imposed on the residential components of the development. The CC&Rs will be comprehensive in nature, and will be enforced by the respective homeowner's associations as use encumbrances on each residential unit and the common areas within each development.

Among the relevant water conservation matters, which will be addressed by the CC&Rs, are the following:

- The uses and operation of reclaimed irrigation water.
- Prohibition against certain wastes including installation or use of automatic (self-generating) water softeners, single-pass cooling systems and non-recycling water fountains and landscaped water features.
- Landscape design controls which encourage the use of drought-tolerant plant materials in private landscaping.
- Restrictions against excessive watering.

### 2.10.13 Designation of Water Conservation Coordinator

The operator will establish the staff position of Water Conservation Coordinator together with other employment duties. The Water Conservation Coordinator's duties will include oversight, management and evaluation of the resort's water conservation programs. The Water Conservation Coordinator will also act as the primary liaison between the resort operations and the SCWD, the City and the public.

## **2.11 Infrastructure**

This section delineates the infrastructure that will be needed to serve the Specific Plan area. The schematic systems for drainage and flood control, domestic water, reclaimed water, and sewer are described and illustrated. In addition, dry utility services are discussed, these include: gas, electric, telephone and television cable service.

### 2.11.1 Drainage and Flood Control

The drainage and flood control service will be coordinated with the City Engineer and the Orange County Environmental Management Agency Flood Control District (FCD). Salt Creek, the primary existing drainageway through the site, has been channelized and partially enclosed in culverts as it winds its way under Camino del Avion, through the project site and out to the ocean. The Salt Creek channel enters the site in a culvert. Approximately 750 feet west of Camino del Avion, it becomes a trapezoidal earthen channel with sufficient capacity to convey run-off from a 100-year storm. The channel runs west through the golf course until approximately 450 feet east of PCH where the channel enters a culvert once again, and crosses under Pacific Coast Highway to an outlet at the Pacific Ocean.

In addition to the Salt Creek Channel, there are several FCD master plan storm drains which traverse the site and empty into the Salt Creek Channel. They were designed to convey run-off from a 25-year storm and outlet into the channel.

The land uses, for which the current facilities were planned, included residential, commercial and a school. The estimated peak flow rates for the currently proposed hotel, residential, golf clubhouse, beach house, and park and opens space uses should be similar to the design peak flow rates used to calculate the size of the facilities. Proposed drainage facilities shall be designed to the current FCD and City standards for flood control.

There are several existing desilting basins on site, which are temporary and provide interim erosion control, resulting from prior grading activity and will be removed when the site is improved. Once the development is complete, desilting basins will no longer be necessary.

According to the Federal Emergency Management Agency's (FEMA) September 15, 1989 Flood Insurance Rate Map, the areas planned for development of permanent structures, eg., the Hotel Village, Clubhouse Village and Beach House site, are in Zone X. Zone X is defined as areas determined to be outside the 500-year flood plain. Pad elevations for permanent, habitable structures will be above the 100-year flood level.

Exhibit 2.29, the Schematic Drainage and Flood Control Plan depicts the backbone storm drain system and appurtenant structures, such as surface gutters, side inlet catch basins, and area drain catch basins, to accommodate the project. This storm drain system is designed to convey run-off from a 25-year return period storm event.

One of the existing facilities in the Hotel Village area, known as K01P02, is an 84-inch cast-in-place pipe, which may need to be horizontally or vertically relocated to accommodate a road across it. There is also a 63-inch cast-in-place pipe through the community park site, which may need to be relocated and/or strengthened. Any necessary relocation or strengthening of this facility, in addition to all new storm drain facilities, will be the responsibility of the developer. See comment 19

#### 2.11.2 Water (Domestic)

Domestic water service will be coordinated with South Coast County Water District (SCWD). Existing facilities include two 12-inch water lines off Niguel Road with a 2-inch meter, and several stubs that are available as connections to provide future service to the hotel and the golf clubhouse as well as the residential enclaves in the Resort Village. There is also an 18-inch water line in Pacific Coast Highway and a stub in the Fairway Condominiums to the west, that are available as connections to provide future service to the residential enclaves in the Hillside Village, in addition to the beach house site.

The domestic water demands for this project are based on projections for the proposed hotel uses and historical water use factors for the residential areas. It is assumed that reclaimed water will be used for irrigating the majority of park and recreation areas, though some potable water will be used for certain areas due to County regulations. However, most of the site including the golf course, park, and some of the hotel and clubhouse gardens will be irrigated with reclaimed water. See section 2.9 Water Conservation and 2.11.3 Reclaimed Water for more detail.

Fire flow is anticipated to be the major criterion for sizing the on-site water system. SCWD standard indicates the fire demand for commercial areas, which covers the Hotel, Clubhouse and Beach House, is a total of 3,500 gallons per minute from any three adjacent fire hydrants with a residual pressure at the main of 25 pounds per square inch. In addition, the hotel, and clubhouse will require water service at several levels ranging from 115 feet to 192 feet. Pad elevations for the residential service will range from 105 feet to 170 feet in the Resort Village and 95 feet to 215 feet in the Hillside Village.

- **Telephone**

Pacific Telephone will provide telephone service to the Specific Plan area. Underground PVC telephone conduits originating at Pacific Coast Highway and Niguel Road will be distributed to pullboxes throughout the site. Service to the Beach House site will originate from the point of connection at the Ritz Cove residential area.

- **Cable**

Dimension Cable Services will provide cable service to the Specific Plan area. Underground PVC cable television conduits originating at Pacific Coast Highway and Niguel Road will be distributed to pullboxes throughout the site. Service to the Beach House will originate from the point of connection at the Ritz Cove residential area.

## **2.12 Noise Mitigation**

In an effort to protect existing and future residents of Dana Point from the negative effects of noise, the Noise Element of the City's General Plan has established numerous goals and policies which have been designated to identify which types of land uses are "noise sensitive," and to establish compatibility criteria for these land uses.

According to the Noise Element, all of the land uses proposed in the Specific Plan are considered to be noise sensitive. Additionally, the Specific Plan area is located along a portion of Pacific Coast Highway and Niguel Road, both of which are designated as "major arterials" and both of which are capable of generating noise levels exceeding 65 decibel level (Db). The Noise Element of the General Plan classifies areas within the 60Db noise contour as "Noise Study Zones" which means that noise levels should be evaluated on a project specific basis and that mitigation measures may be required in order to meet City standards. Areas within the 65Db area are classified as "Noise Mitigation Zones" which means that any new, noise sensitive developments will require the inclusion of mitigation measures in order to comply with City noise standards. Noise mitigation may require special construction techniques or other design criteria to be incorporated into the future development. These measures are provided for in the Specific Plan area as follows:

Prior to issuance of the Site Development/Coastal Development Permit, a site specific noise study will be performed to identify any areas that currently exceed City noise standards or may be expected to exceed them at buildout of the General Plan. Architectural design elements will be included to ensure that both exterior and interior noise standards are at or below the established limits. These design elements may include such things as setbacks, landscaped berms, noise walls, double glazed windows and heavier types of insulation in walls facing noise sources. See comment 20

## **2.13 Community Programs and Facilities**

### **2.13.1 Fire and Emergency Medical Service**

Fire protection and emergency medical service for the Specific Plan area will be provided by the Orange County Fire Department Station 30 on Stonehill Drive and Niguel Road, adjacent to the project site. Two other stations, Station 29 on Victoria Boulevard and Station 49 on Golden Lantern in Laguna Niguel will provide additional fire protection and emergency medical service for the Specific Plan area. Any hazardous material storage and transportation will be done in accordance with local and state regulations.

- **Community Facilities District Financing**

In addition to the formation of an assessment district, the developer may petition the City to initiate proceedings pursuant to the Mello-Roos Community Facilities District Act of 1982 for the purpose of financing the certain community improvements as outlined above.

- **Coastal Access Funding**

The developer and the City will jointly apply for, and cooperate in the consummation of, a program to utilize those funds for the operational expenses of the resort vehicle system. These funds would be obtained by the City and a Dana Point Coastal Access Fund (the "Access Fund") would be created for transit related uses. This initial funding could serve as the base to which other similar access fees could be added for application elsewhere within the City at the discretion of the City.

Hardware and system costs would not be funded by the Access Fund. Costs for the resort vehicles and other system infrastructure would be provided by the developer. Utilizing the Access Fund for operational costs will thereby be a direct support for public use of the resort vehicle system.

## 2.15 Phasing

### 2.15.1 The Phasing Plan

The General Plan Land Use Element includes Policy 8.12, which provides for development of the public open space uses and public roads first, then the hotel complex, and then the residential uses. This policy states that concurrent development may be permissible only if the primary open space and visitor-serving objectives of this policy is being achieved.

Development of a project as complex and multifaceted as the Monarch Beach Resort may feasibly occur in a true incremental manner. Financing, construction logistics, interdependence of one portion of the project upon others, physical constraints and other similar issues may necessitate concurrent operations and construction. A phasing implementation scheme has been created which would allow most work to proceed concurrently, but which would complete first, the primary objective of the development of the public open space and roads; secondly, the resort complex; and lastly, the residential dwellings. See comment 21

To insure implementation of the General Plan phasing policy, the following provisions will apply:

1. Prior to approval of any Site Development Permits and Coastal Development Permits for residential units, the hotel facilities, golf clubhouse, golf course, and Sea Terrace Park must have obtained Site Development Permit approval and Coastal Development Permit approval.
2. Prior to the approval of any Tentative map and Coastal Development Permits for residential units, any required Tentative maps for the hotel facilities, golf clubhouse, golf course and Sea Terrace Park must have obtained all necessary approvals, including Coastal Development Permit approval.
3. Prior to the recordation of any final subdivision maps for residential units, all required final subdivision maps for the hotel facilities, golf clubhouse, golf course and Sea Terrace Park must have been recorded.

In the event that any unforeseen factors delay the processing of the Site Development Permit application or subdivision map applications for the hotel facilities, golf clubhouse, golf course, or Sea Terrace Park, the City may permit deviations from the three provisions outlined above, provided there are adequate safeguards to insure implementation of the General Plan Phasing Policy.

In addition the developer shall prepare and obtain approval of a Phasing Plan (PP) from the Planning Commission prior to the recordation of any Final Map. A primary objective of the PP is that the development of the public open space and roads occur first, and that the hotel construction precede residential construction and that residential units not be completed or occupied prior to completion of the hotel. The PP shall contain and/or address the following:

1. In accordance with the "Release and agreement regarding additional development of Sea Terrace Community Park" dated 20 June, 1991 between Monarch Bay Resort, Inc. and the Capistrano Bay Parks and Recreation District, the developer shall complete construction of Sea Terrace Park and the other park and open space features on or before the opening of a resort hotel on Developer Property and prior to the construction of any residential units.
2. Prior to the issuance of Coastal Development Permits and building permits for any residential units, Coastal Development Permits and building permits for the hotel must be issued.
3. Prior to conducting framing inspections for any residential units, the hotel must have obtained roof inspection approval. The PP will address in detail what constitutes roof inspection and framing inspection approvals.
4. The PP may make provision for the construction of model homes and temporary sales facilities for sales purposes. Coastal Development Permits and building permits for model homes may not be issued until Coastal Development Permits and building permits for the hotel are issued. Model homes may not be sold, or occupied for purposes other than sales activities, until after the Certificate of Occupancy for the hotel is obtained.
5. Prior to closing escrow on or occupying or issuance of any final inspection for any residential units, the hotel must have obtained a Certificate of Occupancy.
6. If unforeseen circumstances delay compliance with minor aspects of the PP, a provision to insure compliance with these requirements can be facilitated through cash payments or other forms of security acceptable to the City. Prior to or concurrent with acceptance of such cash payments or other forms of security, the City shall develop a program specifically stating how the cash payments or other forms of security will be used to ensure compliance with the PP requirements.
7. The PP will be clearly referenced in each final Map. The PP will be referenced in the title. The PP shall be a condition of approval of all Coastal Development Permits for development proposed in this Specific Plan. Any subsequent developers and/or owners shall submit a letter to the City certifying that they have read the PP and acknowledge and accept all its provisions.

## 2.16 Fiscal Impact

The development of the Monarch Beach Resort Specific Plan area is projected to provide a positive fiscal impact to the City of Dana Point. The highest land use for revenue generation for the City is visitor serving commercial

and associated facilities.

The development of the Specific Plan area as documented in the report prepared by Stanley R. Hoffman Associates, dated May 8, 1991, will generate substantial fiscal surplus even where revenue generation for the visitor serving commercial area are low; as the fiscal impact are positively skewed.

The Fiscal Impact Analysis conducted by Stanley R. Hoffman Associates projects that the project as described in the Specific Plan will generate at buildout approximately \$2.5 million of annual revenue to the City of which approximately \$2.2 million will be a recurring annual surplus over recurring annual costs.

The Specific Plan provides for the development of an integrated resort. With each component reliant on the opportunity to create a unique environment which should attract visitors and hotel guests together with long term residents to the City and provide the local economy with business opportunities. The hotel of the size anticipated for the Specific Plan would generate approximately \$25 million of revenue per annum.

This development of the Specific Plan area will result in a stimulus to jobs and economic growth as well as increased spending on goods and services in the City. In addition, the revenue provided to the City by the project will also create job opportunities through subsequent City expenditures.

The Specific Plan and development standards provides for a high quality 5-star development which should result in the project being a focal point for the area which is known throughout the world, which should further focus the City as a destination resort community.

The Specific Plan is a development, which meets the economic goals and objectives of the General Plan and provides an important benefit and contribution to the local economy. The City needs to consider incentives prior to building approvals to ensure that the goals of the City are achieved. A development of this type for the Monarch Beach Specific Plan area requires the cooperation from the City to enable the development to proceed quickly.

The developer will be responsible for its fair share of programs established by the City at the time of the Monarch Beach Resort Specific Plan approval. Determination of the fair share assessment shall be based upon a review of several factors. The assessment shall be made in consideration of: 1) the procedure for calculating the fee amount for already approved visitor- serving uses; 2) public infrastructure improvements agreed to by the developer; 3) public improvement and impact fees; 4) the project's significant positive revenue contribution to the City; 5) the contribution to local business; 6) the City's expedited Specific Plan, Site Development Permit and Tentative Tract approval processes; 7) Modification to the City's development standards; and 8) The City's General Plan.

The City has adopted development impact fees (City Council Resolutions 91-12-10-5, 91-12-10-6, and 91-12-10-6) for General Government Facilities, Fire Protection Facilities and Transportation Facilities. These development impact fees apply to all development within the City of Dana Point including all development within the boundaries of this Specific Plan. **See comment 22**

Section 6 in each of the development impact fee resolutions is worded as follows:

Section 6. For each fiscal year and prior to July 1 of the fiscal year, commencing with the 1991-93 fiscal year, the Director of Community Development shall review the use of the Fee, the continued need for the facilities, the reasonable relationship between the need for facilities and the impact of the various types of development on which the Fee is imposed, and the estimated reasonable cost of the facilities identified in the Report. The Director of Community Development shall report his findings to the City Council at a noticed public hearing and

**Bicycle Lane (Class II facility)** - A corridor expressly reserved for bicycles, existing on a street or roadway in addition to any lanes for use by motorized vehicles.

**Bicycle Path (Class III facility)** - A facility shared with motorists and identified only by signs, a bicycle route has no pavement markings or land stripes.

**Bikeway** - A term that encompasses bicycle lanes, bicycle paths, and bicycle routes.

**Building Coverage** - The percentage of the net lot area which is covered by all the buildings on a lot as seen from a plan view.

**Building Height** - The vertical distance, measured at the exterior wall, by which a building extends above finished grade, finished pad elevation or flood protection level, whichever is lower, to the highest point of a parapet on a flat or non-sloping roof or a mansard roof, and to the mid-point of a pitched or sloping roof.

**Building Pad** - The level area of a lot designed for the construction of buildings and structures.

**Bus Turnout** - A paved indentation in the curb of a roadway designed to allow buses to pull off to the side and stop while picking up and dropping off passengers.

**Certificate of Occupancy** - A document issued to allow a building to be occupied or used and certifying that the building or structure has been constructed, or will be used, in compliance with all the applicable municipal codes and ordinances.

**Certified Local Coastal Program** - A local coastal program which has been effectively certified by the California Coastal Commission pursuant to Section 30512 and 30513 of the Coastal Act as amended. (See definition of "Local Coastal Program" in Section 9.75.120 of the Zoning code). (Coastal).

**City** - Universal term encompassing City Council, Planning Commission and City staff.

**City Council** - City Council of Dana Point

**Club** - A group of people organized for a common purpose to pursue common goals, interests or activities and usually characterized by certain membership qualifications, payment of dues, regular meetings, a constitution and by-laws.

**Clubhouse Village** - The Specific Plan sub-area containing the golf course clubhouse and surrounding residential areas, generally adjacent to Pacific Coast Highway and Monarch Bay Plaza.

**Coastal Commission** - The California Coastal Commission or its successor agency as created pursuant to Division 20 of the Public Resources Code as amended. Whenever the term California Coastal Zone Conservation Commission appears in any law, it means the California Coastal Commission. (Coastal).

**Coastal Conservancy** - The agency established by the Coastal Act of 1976, along with the Coastal Commission. The agency's role is to facilitate increased coastal access and recreation opportunities.

**Coastal Development Permit** - Any license, certificate, approval, or other entitlement for use granted or denied by any public agency which is subject to the provisions of Division 20 of the Public Resources Code as amended. (Coastal Act/30110).

**Coastal Sage Scrub** - A local plant community indigenous to Southern California that typically grows on coastal slopes.



**Enclave, Residential** - The residential neighborhoods of Monarch Beach Resort.

**Endangered Species** - Plant or animal threatened with extinction pursuant to a determination by state and/or federal governments.

**Endangered Species Act (State)** - The California Endangered Species Act administered by the State Department of Fish and Game that generally prohibits the taking of listed endangered species.

**Endangered Species Act of 1973** - The federal Endangered Species Act administered by the U.S. Fish and Wildlife Service that generally prohibits the taking of listed endangered species.

**Enhanced Paving** - Street or landscape paving using special materials such as stamped concrete, stone or brick typically used to define entries or special use areas.

**Floor Area Ratio, Standard (F.A.R.)** - The total gross floor area, including habitable subterranean floors, but not parking structures, of all buildings on a lot divided by the lot area.

**Fuel Modification** - Modification by thinning and/or removal of natural land vegetation such as Coastal Sage Scrub so that fire hazards to adjacent structures are reduced.

**Golf Course** - For the purposes of the Specific Plan, the Links at Monarch Beach, as expanded and modified.

**Golf Clubhouse** - The clubhouse facility located within the Clubhouse Village parcel of the Specific Plan.

**Grade** - The average of the finished ground level (finished grade) at the center of all exterior walls of a building or, where such walls are parallel to and within five feet of a sidewalk, the average of the finished ground level at the sidewalk, or to the top of curb, where there is no sidewalk.

**Grade, Adjacent** - Finish grade at the base of a building wall.

**Grade, Natural** - The elevation of the ground surface in its natural state, before man-made alternations.

**Grade, Pre-existing** - The elevation of the ground which exists prior to the start of any site preparation, grading, or construction related to the project being proposed. Pre-existing grade will not be the same if the site has been previously graded for a project.

**Grading, Contour** - A grading concept designed to result in earthforms and contours which resemble natural terrain characteristics, with generally curving, non-linear slope banks having variations in the slope ratios of the horizontal and vertical curves.

**Grading, Corrective** - Grading associated with remediating geologic hazards such as landslides.

**Grading, Finish** - Grading to establish final elevations and contours of land.

**Grading, Transition** - Grading techniques utilized in areas where there is a major change of contour such as flat area to slope so that technically appropriate and/or aesthetically pleasing conditions are created.

**Ground Plane Plantings** - Landscape materials such as turf and low ground covers.

**Guest Parking** - Parking spaces provided with a residential unit for intermittent use by visitors and parking for hotel and clubhouse uses.

1976 (as amended) at the local level. The Local Coastal Program for the City of Dana Point is comprised of the Land Use Element, Urban Design Element, and Conservation/Open Space Element of the General Plan, the Zoning Code, the Dana Point Specific Plan/Local Coastal Program, and the Capistrano Beach Specific Plan/Local Coastal Program. (Coastal Act/30108.6).

**Lot A** - A lettered lot near Camino del Avion in Salt Creek planned for golf course expansion and Coastal Sage Scrub re-vegetation.

**Lot Area or Size, Net** - The area within the lot lines of a lot exclusive of any dedications for public rights-of-way, public parks and public school sites. To generally calculate net area, 80 percent of the gross area may be assumed to constitute net area; however, a precise determination of net lot area is based on an exclusion of the actual area used for public rights-of-way, public parks and schools.

**Lot Depth** - The average linear measurement between the front and rear lot lines when measured at 90 degree angles from the front lot line.

**Lot Width** - The average linear distance between side lot lines when measured parallel to the front lot line.

**Manufactured Slope** - A man-made slope engineered and constructed to specific standards.

**Maximum Lot (Building) Coverage** - The maximum area of the lot that may be covered by buildings and roofed structures. This may be expressed in square footage or as a percentage of the minimum lot area.

**Mesic** - Relatively moist natural landscape conditions.

**Mid Point of Roof** - The mid point of a sloping or pitched roof means the average of the vertical distance between the top plate of the exterior wall and the highest point or ridge of the roof associated with that wall.

**Minimum Lot Area** - The amount of land that must be contained in a lot for a dwelling unit to be built on that lot.

**Mycorrhizae** - A symbiotic association of the mycelium of a fungus with the roots of a seed plant.

**Negative Declaration, Mitigated** - Documentation and findings pursuant to the California Environmental Quality Act that a project has no adverse environmental impacts, as defined by CEQA, upon implementation of all mitigation measures specified in the certified environmental documentation. All identified adverse impacts before mitigation must be reduced to levels of insignificance as defined by CEQA.

**Off-Street Parking Space** - A permanent parking space for a motor vehicle that conforms to Specific Plan or other applicable city standards and not located on a private or public street right-of-way.

**On-Street Parking Space** - A permanent parking space for a motor vehicle that conforms to Specific Plan or other applicable City standards that is entirely located within a private or public street right-of-way.

**Open Space, Common** - Land within or related to a development, not individually owned or dedicated for public use, which is designed and intended for the common use or enjoyment of the owners of the development and which may include such complementary structures facilities and improvements such as gazebos, recreational facilities, pools, spas, and game courts.

**Open Space, Private** - An open space, fenced or otherwise, designed to promote privacy, and which is reserved for the exclusive use of the occupants of a specific dwelling unit.

**Open Space, Public** - Open space owned and maintained by a public agency for the use and enjoyment of the general public.

**Principal Use** – A use that constitutes the primary function of a household, building, structure, establishment, or property.

**Product Type** - Residential floor plans and elevations depicting a particular type of home.

**Project** - The entire parcel of real property, including all structures thereon, all or part of which undergoes or is proposed to undergo construction, demolition, or a change in ownership status.

**Public Utility Easement** - An easement in which underground or above-ground utilities are located.

**Quimby Act** - The state law which sets forth basic requirements for park acreage or in lieu fees for local parks.

**Recreation/Open Space** - The General Plan designation for the golf course and community park and other open space uses of the Specific Plan.

**Residential** - General Plan and Specific Plan land use designations for residential areas in the property.

**Resort Vehicle System** - A vehicle designed to transport guests of the resort and the general public through the resort and adjacent areas as described in the Public Access section of Chapter 2.0 of the Specific Plan.

**Resource Enhancement Program** - The Specific Plan program delineating the measures to be undertaken to create new Coastal Sage Scrub Habitat in the Specific Plan area.

**Resource Enhancement Plan** - The detailed plans and specifications to implement the Resource Enhancement Program.

**Retaining Wall** - A wall constructed to retain earth and made of concrete, brick, wood, or rock.

**Riding and Hiking Trails** - A trail or way designed for or used by equestrians, pedestrians, and cyclists using non-motorized bicycles.

**Right-of-Way** - A corridor, either public or private, on which a right of passage has been recorded.

**Riparian Habitat** - An environment associated with freshwater watercourses, including perennial and intermittent streams, lakes, and other bodies of fresh water, and characterized by plants and animals which are dependent upon the availability of water in the resource.

**Roof, Gable** - A roof containing two sloped roof planes, typically located on larger sides of a rectangular structure.

**Roof, Hip** - A roof containing sloped planes corresponding to each side of a structure.

**Roof, Shed** - A roof containing a single sloped plane.

**Salt Creek** - The major drainage channel in the Specific Plan area.

**Salt Creek Regional Corridor** - The open space owned by the County of Orange upstream of Caminodel Avion in the City of Laguna Niguel.

**Setback Line** - A line within a lot, parallel to and measured from a corresponding lot line, forming the boundary of a required yard and governing the placement of buildings/structures and uses on a lot.

**Significant** - Having or likely to have influence or affect, as defined in the California Environmental Quality Act.

**Site** - Any lot or parcel of land or combination of contiguous lots or parcels of land used or intended for a particular use or group of uses.

**Site 2/3** - The Hotel Village parcel.

**Site 3** - Clubhouse Village South parcel.

**Site 16** - The northerly 8.8 acres of the Clubhouse Village parcel, also known as Clubhouse Village North.

**Site Adaptive Structures/Residential Units** - Residences designed to accommodate the terrain of an area, especially hillside conditions.

**Site Development Plan** - A precise plan of development that may be subject to public hearing before the Planning Commission.

**Site Development Permit** - An approval which is required prior to the development of certain structures or uses in a particular district or zone. This permit is required for most non-restricted uses and is typically utilized to ensure compliance with the district development regulations and to identify necessary improvements, requirements, and dedications.

**Site Plan** - A diagram of a property proposed for development as seen from above. The diagram shall be drawn to scale and properly dimensioned. The diagram shall illustrate the existing and proposed uses and structures on the property in accordance with the applicable regulations and shall include lot lines, streets, grades, building sites, landscaping, parking areas, structures, and uses on adjacent parcels, reserved open space and other specific development proposals.

**Slope, Contoured** - Man-made slopes containing variable gradients.

**Specific Plan** - A detailed plan for the development of a specific area. It implements the local General Plan by creating a bridge between General Plan policies and individual development proposals. A Specific Plan directs all facets of future development; from the distribution of land uses to the location and sizing of supporting infrastructure, from methods of financing public improvements to standards of development.

**Stabilized Decomposed Granite** - Granite material similar in texture to very coarse sand, used with a stabilizing and binding agent such as soil cement for low-maintenance paths or roadways.

**Standards, Development** - Requirements in Chapter 3 of the Specific Plan that govern building and development including lot area, height limits, landscaping, and floor area ratios, etc.

**Story, Full** - That portion of the building included between the surface of any floor and the surface of the floor next above it, or if there be no floor above it, then the space between the floor and the ceiling above it. Basements and underground parking lots shall be counted as a story if the vertical distance from the average adjoining grade of the basement or underground story is over five feet.

**Street, Private** - A right-of-way, easement or lot, designated for vehicular access, that is not dedicated to the public and held in private ownership, which provides internal access to or through a property.

**Street, Public** - A right-of-way designed for vehicular access that is dedicated to the public.

**Temporary Use** - A use established for a fixed period of time with the intent to discontinue such use upon the expiration of the time period.

**Toe of Slope** - The base of a man-made slope.

**SPECIFIC PLAN CONSISTENCY WITH  
GENERAL PLAN POLICIES**

---

**APPENDIX B**

## GENERAL PLAN POLICIES

## SPECIFIC PLAN CONFORMANCE WITH GENERAL PLAN

### Land Use Element

- |     |  |  |
|-----|--|--|
| 1.1 | Develop standards for building intensity, including standards for ground coverage, setbacks open space/landscaping, maximum dwellings per acre, floor area ratios, size and height restrictions.   | The Specific Plan provides development standards for building intensity, including standards for setbacks, open space/landscaping, maximum dwellings per acre floor area ratios, size and height restrictions. Site development/coastal development plan/permit requirements are also set forth to this end.   |
| 1.2 | Establish maximum intensities of development for each of the various land use categories.  | Maximum intensities of development for each of the Specific Plan land use categories have been established as part of the Development Standards.   |
| 1.3 | Assure that land use <u>intensities</u> are consistent with <u>capacities</u> of existing and planned public service facilities. (Coastal Act/30250,30254)   | The Specific Plan provides the mechanisms for financing improvements to public service facilities that will be directly impacted by the development of this project.   |
| 1.4 | Assure that adequate recreational areas and open space are provided as a part of a new residential development.  | The Park and Open Space Concept Plan provides more than adequate recreational and open space areas as well as improvements and maintenance for these areas as part of the new residential development. Sea Terrace Park, additional public open space such as the crescent promenade, vista points and comprehensive trail and coastal access system are examples. |
| 1.5 | Work closely with Orange County to plan for the future development within the Harbor Area and to assure that additional development is compatible with existing uses and enhances the scenic and recreational and visitor opportunities for the area. (Coastal Act/30220-224, 30233, 30234, 30250, 30252, 30). | This policy is not applicable as the Harbor area is not within or adjacent to the Specific Plan area.  |
| 1.6 | Encourage the development of unified or clustered commercial centers and neighborhood commercial centers rather than continued development of strip commercial. (Coastal Act/30250)  | The Specific Plan delineates a resort hotel and spa with conference facilities, restaurants and retail shops which are clustered in one area, a golf clubhouse with meeting facilities and restaurants is clustered in another area, and a beach house dining facility is planned along the shoreline. No strip commercial is planned.                             |

## GENERAL PLAN POLICIES

## SPECIFIC PLAN CONFORMANCE WITH GENERAL PLAN

### Land Use Element (Cont.)

- |     |   |  |
|-----|---|--|
| 1.7 | Require comprehensive analysis and mitigation for any proposed General Plan Amendment to ensure that the amendment will result in a desirable mixture of land uses meeting the social and fiscal needs of the City and its residents. | This policy is not applicable since no General Plan Amendment is anticipated for this project. The land uses delineated in this Specific Plan are consistent with those established in the General Plan for this area.   |
| 2.1 | Consider the impacts on surrounding land uses and infrastructure when reviewing proposals for new development. (Coastal Act/30260-264)  | The impacts on surrounding land uses and infrastructure have been considered and mitigation measures have been provided where necessary as part of the environmental documentation for this project.   |
| 2.2 | Prohibit on-shore support facilities for oil drilling. (Coastal Act/30260-264)  | This policy is not applicable as no oil drilling support facilities are planned as part of this project.   |
| 2.3 | Visitor serving commercial areas shall not intrude into existing residential communities. (Coastal Act/30250)   | The proposed visitor serving commercial areas are intended to be surrounded by residential uses within the Specific Plan area and do not intrude into existing residential communities.  |
| 2.4 | Develop regulatory mechanisms to mitigate land use conflicts.   | The zoning and development standards in this Specific Plan and the mitigation measures in the environmental documentation provide mechanisms to avoid land use conflicts.  |
| 3.1 | Require new development to contribute its share of the cost of providing necessary public services and facilities through equitable development fees and exactions. (Coastal Act/30250)   | The Specific Plan provides programs to ensure that this development contributes its fair share of fees to cover the cost of providing necessary improvements to public services and facilities. The construction and maintenance programs for Sea Terrace Park, the trail system, infrastructure and housing are examples. |
| 3.2 | Coordinate Dana Point's land use and growth policies with the county and other communities in the region to strengthen and promote inter- jurisdictional communication and cooperation.   | The Specific Plan reflects the land use and growth policies established by Dana Point in conjunction with those of the County and other communities in the region to strengthen and promote interjurisdictional communication and cooperation.   |

## GENERAL PLAN POLICIES

## SPECIFIC PLAN CONFORMANCE WITH GENERAL PLAN

### Land Use Element (Cont.)

- |     |   |  |
|-----|---|--|
| 3.3 | Priority should be given to those projects that provide for coastal recreational opportunities. (Coastal Act/30210-212, 30220-224)  | This Specific Plan provides for a variety of coastal recreational opportunities including a golf course, resort vehicle system parks and open space features and bicycle and pedestrian trails that promote coastal access and recreation.   |
| 3.4 | Examine the short term and long term fiscal effects of development and re-development decisions.  | The short term and long term fiscal impacts of this project have been analyzed in the Fiscal Analysis dated May 8, 1991, prepared by Stanley R. Hoffman Associates. The Specific Plan reflects the findings of this analysis through design and phasing.   |
| 3.5 | Public facilities must be distributed throughout the coastal area to eliminate overcrowding and overuse in one single area. (Coastal Act/30212.5, 30254)  | The variety of public facilities planned for the project are distributed appropriately throughout the Specific Plan area and will eliminate overcrowding and overuse of any one area. The Specific Plan provides for land uses and facilities of considerably lower intensities than previously approved plans for the area. |
| 3.6 | Encourage patterns of development necessary to minimize air pollution and vehicle miles traveled. (Coastal Act/30250)   | The Specific Plan provides for a series of pedestrian and bike trails as well as a resort vehicle system to help minimize air pollution and vehicle miles travelled. The majority of the property will be developed as non-polluting open space.   |
| 3.7 | Encourage safe and convenient bicycle and pedestrian access throughout the community. (Coastal Act/30210-212.5, 30250, 30252)   | A variety of off-road bicycle and pedestrian trails are intended to provide safe and convenient access throughout the Specific Plan area.  |
| 3.8 | Allow increases in intensity up to the maximum floor area ratio identified in the Land Use Element only where development projects demonstrate exceptional design quality, important public amenities or public benefits, or other factors that promote important goals and policies of the General Plan. | The guidelines, policies programs and development standards in this Specific Plan will ensure the implementation of exceptional design quality, and important public amenities and benefits. Floor area ratios for the Specific Plan uses are well below these prescribed in the General Plan.                               |

See comment 23



## GENERAL PLAN POLICIES

## SPECIFIC PLAN CONFORMANCE WITH GENERAL PLAN

### Land Use Element (Cont.)

- |      |  |   |
|------|--|---|
| 3.9  | Designate the right-of-way for Alipaz Street for Recreation/Open Space use if Alipaz Street is removed the Master Plan of Arterial Highways in the future.   | This policy is not applicable as Alipaz Street is not within or adjacent to this Specific Plan area.  |
| 3.10 | Consider designating vacated street rights-of-way for Recreation/Open Space use.   | This policy is not applicable as there are no vacated rights-of-way within the Specific Plan area.  |
| 3.11 | Provide congestion management and mitigation for increased demand for affordable housing due to the creation of significant additional employment opportunities.   | This policy is not applicable as the Land Use Designations in the General Plan do not provide for affordable housing land uses within the Specific Plan area.   |
| 4.1  | Exclude areas designated as Recreation/Open Space and areas containing wetlands, beaches, and bluffs from the calculation of net acreage available for determining development intensity or density potential. | All recreation/open space areas have been excluded from the calculation of net acreage available for determining development intensity or density potential. However, there are no wetlands or beaches in the Specific Plan area to be excluded from the net acreage calculation.                         |
| 4.2  | Consider the constraints of natural and man-made hazards in determining the location, type and intensities of new development. (Coastal Act/30240, 30253)  | This Specific Plan has considered the constraints of natural and man-made hazards in determining the location, type and intensities of new development. Soils constraints on site have been considered in planning the intensity and design of residential and visitor recreation commercial development. |
| 4.3  | Provide and protect public access and recreational opportunities to the coastal area. (Coastal Act/30210-212.5, 30213, 30220-224)  | The golf course, beach house, community park, public open space features, resort vehicle system and trail designations established in this Specific Plan provide and protect public access and recreational opportunities to the coastal area.  |

See comment 24

## GENERAL PLAN POLICIES

## SPECIFIC PLAN CONFORMANCE WITH GENERAL PLAN

### Land Use Element (Cont.)

- |     |   |  |
|-----|---|--|
| 4.4 | Preserve, maintain and enhance marine resource areas and coastal water. (Coastal Act/30230-232, 30235-236)                                    | The Specific Plan provides safeguards for development which will allow for the preservation and maintenance of marine resource areas and coastal water near the project site. Enhancements to the redesigned golf course and maintenance programs will assure that marine resources and coastal waters will be protected. There are no marine resource and coastal waters within the Specific Plan area. |
| 4.5 | Consider the environmental impacts of development decisions. (Coastal Act/30240, 30241, 30242, 30243, 30244)                                  | A Mitigated Negative Declaration has been prepared which analyzes the environmental impacts of the development decisions established in this Specific Plan.  |
| 4.6 | Ensure land uses within designated and proposed scenic corridors are compatible with scenic enhancement and preservation. (Coastal Act/30251) | A Visual Analysis has been prepared as part of this Specific Plan which demonstrates that land uses within designated and proposed scenic corridors are compatible with scenic enhancement and preservation. Height limits have been established in the zoning and development standards reflective of that analysis.  |
| 4.7 | Coordinate with appropriate Park, Recreation and Harbor Agencies to enhance Open Space trails and bike paths. (Coastal Act/30210-212.5)       | The Specific Plan trails system and the Sea Terrace Park Site Plan reflects coordination with appropriate Park, Recreation and Harbor Agencies to enhance Open Space trails and bike paths.  |
| 4.8 | Encourage the reasonable regulation of signs to preserve the character of the community. (Coastal Act/30251)                                  | The Specific Plan provides for a comprehensive sign program subject to discretionary review.   |
| 4.9 | Encourage the preservation of significant natural areas as cohesive open space.   | This Specific Plan contains a Resource Enhancement program which provides for the creation and enhancement of a significant area as native wildlife habitat.   |
| 5.1 | Preserve the opportunity of public views from the Headlands site to the coastal areas and the harbor areas. (Coastal Act/30251)               | This policy is not applicable as the Headlands site is not within or adjacent to this Specific Plan area.  |

## GENERAL PLAN POLICIES

## SPECIFIC PLAN CONFORMANCE WITH GENERAL PLAN

### Land Use Element (Cont.)

- |     |   |   |
|-----|---|---|
| 5.2 | Require geotechnical studies to ensure geological stability in the areas where development is to be permitted and require adequate setbacks from the blufftop areas in accordance with those engineering studies and adopted City regulations. (Coastal Act/30250, 30253) | This policy is not applicable as the Headlands site is not within or adjacent to this Specific Plan area. |
| 5.3 | Preserve natural open space in the Headlands area, especially along the coastal bluffs, and provide open areas integrated throughout the development. (Coastal Act/30210-212.5, 30250, 30253)   | This policy is not applicable as the Headlands site is not within or adjacent to this Specific Plan area. |
| 5.4 | Assure that the height and scale of the development in the Headlands are compatible with the development in the community and that the visual impact of the development from coastal areas below the project be minimized. (Coastal Act/30251)                            | This policy is not applicable as the Headlands site is not within or adjacent to this Specific Plan area. |
| 5.5 | Promote the development of a mixture of land uses which may include residential, visitor-serving commercial, recreational open space, and community facilities. (Coastal Act/30213, 30250)  | This policy is not applicable as the Headlands site is not within or adjacent to this Specific Plan area. |
| 5.6 | Require that the scenic walkway be extended throughout the Headlands and connect to the existing or proposed walkways. (Coastal Act/30210-212)  | This policy is not applicable as the Headlands site is not within or adjacent to this Specific Plan area. |
| 5.7 | Provide vehicular access that does not adversely impact adjoining neighborhoods or create congestion on the Pacific Coast Highway.  | This policy is not applicable as the Headlands site is not within or adjacent to this Specific Plan area. |
| 5.8 | Provide patterns of land use and circulation in the Headlands that enhance public and private pedestrian access and circulation within the area. (Coastal Act/30250)  | This policy is not applicable as the Headlands site is not within or adjacent to this Specific Plan area. |

See comment 25

**GENERAL PLAN POLICIES**

**SPECIFIC PLAN CONFORMANCE  
WITH GENERAL PLAN**

**Land Use Element (Cont.)**

- |      |   |  |
|------|---|--|
| 5.9  | Provide extensive public trails within the Headlands area. The system shall include access to the beach and to the visitor-serving and public places within the Headlands.    | This policy is not applicable as the Headlands site is not within or adjacent to this Specific Plan area.      |
| 5.10 | Encourage visitor-serving resort facilities and land uses of a world-class stature.   | This policy is not applicable as the Headlands site is not within or adjacent to this Specific Plan area.      |
| 5.11 | Assure the Specific Plan for the Headlands provides buffers to achieve a compatible and enhanced relationship to existing surrounding land uses.                              | This policy is not applicable as the Town Center area is not within or adjacent to this Specific Plan area.    |
| 6.1  | Provide a diversity of retail office and residential land uses that establish the Town Center as a major center of social and economic activity in the community.             | This policy is not applicable as the Town Center area is not within or adjacent to this Specific Plan area.    |
| 6.2  | Encourage retail businesses and mixtures of land uses that help to generate pedestrian activity in the area.  | This policy is not applicable as the Town Center area is not within or adjacent to this Specific Plan area.    |
| 6.3  | Establish patterns of land uses and circulation that promote the desired pedestrian character of the area.  | This policy is not applicable as the Town Center area is not within or adjacent to this Specific Plan area.    |
| 6.4  | Through effective design guidelines encourage building designs, intensity and setbacks to be compatible with the desired scale and character of the area. (Coastal Act/30251) | This policy is not applicable as the Town Center area is not within or adjacent to this Specific Plan area.    |
| 6.5  | Develop land use and parking regulations to assure that adequate and reasonable standards are provided.   | This policy is not applicable as the Town Center area is not within or adjacent to this Specific Plan area.    |
| 6.6  | Provide opportunities for shared parking facilities in the Town Center, such as through the establishment of an off-street parking district.                                  | This policy is not applicable as the Doheny Village area is not within or adjacent to this Specific Plan area. |

## GENERAL PLAN POLICIES

## SPECIFIC PLAN CONFORMANCE WITH GENERAL PLAN

### Land Use Element (Cont.)

- |     |   |   |
|-----|---|---|
| 7.1 | Promote the Doheny Village area as a major shopping and business center in the community.   | This policy is not applicable as the Doheny Village area is not within or adjacent to this Specific Plan area.  |
| 7.2 | Through revitalization activities improve the appearance of the area through landscape design and pedestrian amenities.   | This policy is not applicable as the Doheny Village area is not within or adjacent to this Specific Plan area.  |
| 7.3 | Develop design guidelines that assure that development will be consistent in terms of scale and character. (Coastal Act/30251)  | This policy is not applicable as the Doheny Village area is not within or adjacent to this Specific Plan area.  |
| 7.4 | Promote the development of land uses in the Doheny Village area that provide employment opportunities for the community including offices, marine-oriented industrial uses, and other commercial or light industrial business activities or community facilities. | This policy is not applicable as the Doheny Village area is not within or adjacent to this Specific Plan area.  |
| 7.5 | Encourage the development of a diversity of housing opportunities in the area including medium density housing in the areas adjacent to the retail areas and also as a part of mixed residential and retail or office uses.                                       | This policy is not applicable as the Doheny Village area is not within or adjacent to this Specific Plan area.  |
| 7.6 | Provide for adequate and convenient parking areas. Encourage the provision of shared parking facilities, such as through the establishment of a parking district.   | This policy is not applicable as the Doheny Village area is not within or adjacent to this Specific Plan area.  |
| 7.7 | Prepare a Specific Plan for revitalization of the Doheny Village Area. The Specific Plan should involve extensive public input.   | This policy is not applicable as the Doheny Village area is not within or adjacent to this Specific Plan area.  |
| 8.1 | Preserve the opportunity of public view corridors from Monarch Beach area to the coast. (Coastal Act/30251)   | As part of the Specific Plan, the opportunity of public view corridors from Monarch Beach area to the coast have been maintained along Niguel Road, the golf course and Sea Terrace Park. |

**GENERAL PLAN POLICIES**

**SPECIFIC PLAN CONFORMANCE  
WITH GENERAL PLAN**

Land Use Element (Cont.)

8.2 ✓ Assure that adequate recreational areas and open space are provided and maintained by the developer as part of a new development.

The Specific Plan assures that adequate recreational areas and open space are provided and maintained by the developer as part of the new development through the golf course expansion, Sea Terrace Park, and the trails system.

8.3 ✓ Assure that the height and scale of new community development is compatible with the existing areas.

The Development Standards in the Specific Plan provide height and scale requirement for new community development that is compatible with the existing areas.

8.4 ✓ Promote the development of a mixture of residential, visitor-serving, and open space land uses; with an ultimate residential density cap of 238 dwellings, which shall not be exceeded.

The Land Use in this Specific Plan and Statistical Summary provide for the development of a 400 key hotel, golf course, clubhouse, beach house, and park uses; An ultimate residential unit cap of 238 dwellings, which shall not be exceeded is part of the Specific Plan Zoning, and Development Standards.

8.5 ✓ Require that the pedestrian and bike trail systems be extended throughout Monarch Beach and connected with the existing and planned citywide trail system.

The Specific Plan delineates a network of pedestrian and bike trail network that extends throughout this project area and is connected with the existing and planned citywide trail system.

8.6 H Provide extensive public trail and transit loop systems within the Monarch Beach area. The systems shall include access to the beach and to the visitor-serving and public places within Monarch Beach.

The Specific Plan delineates extensive public trails within the Monarch Beach area. The systems shall include access to the beach and to the visitor-serving and public places within Monarch Beach. Joint consideration by the City and the resort developer of a coastal access enhancement program is a policy of the Specific Plan.

8.7 Encourage public access and visitor-serving land uses with a strong public component which allows the public to enjoy such visitor-serving commercial facilities.

The Specific Plan provides public access and visitor-serving land uses through the trails and resort vehicle system, the 400 key hotel, golf clubhouse, and golf course facilities.

8.8 X Allow a beach house as a public commercial facility near the beach. This beach house shall only be accessed by the beach, public trail, and transit loop systems.

The Specific Plan delineates a beach house as a visitor recreation commercial facility. The Specific Plan shows the access to the beach house from the beach, public trails and the resort vehicle system.

## GENERAL PLAN POLICIES

## SPECIFIC PLAN CONFORMANCE WITH GENERAL PLAN

### Land Use Element (Cont.)

- 8.9 Avoid expansion of the golf course or any other land use that occurs at the expense of public park area. *02.10.12*
- The Land Use Plan shows the golf course and other land use limited to the areas designated in the General Plan for such uses. No development is planned at the expense of public park area.
- 8.10 Encourage the immediate development of visitor serving resort facilities and land uses of a world class stature to be achieved within five years from the date of adoption of the General Plan. The resort facility shall include a 400 or so key five star resort hotel. If public open space and Visitor/ Recreational/Commercial land uses are not physically developed and established within five years, it is the policy of the City of Dana Point to revisit other land uses within this area and to assure the provision of open space and Visitor/ Recreation/ Commercial activities.
- The Phasing Plan and policies in this Specific Plan provide for the immediate development of visitor serving resort facilities of a world class stature to be achieved within five years from the date of adoption of the General Plan. The resort shall include a 400 key five star resort hotel and associated uses and phased residential development.
- 8.11 Provide for the temporary landscaping of existing graded pads with perennial wild flowers and other vegetation to assure aesthetic enhancement of the area, reduce soil erosion, and reinforce the ultimate open space and landscaped resort character of the area.
- The Specific Plan provides for the landscaping of existing graded pads to assure aesthetic enhancement of the area where feasible. A corner of vegetative matter exists on the property which is believed to fulfill this policy requirement. The developer intends to begin construction of the project at the earliest practicable date. The landscape program described in the Specific Plan provides for comprehensive plantings of all areas in a quality manner.
- 8.12 Within the Specific Plan, establish a development phasing plan to achieve first, the primary objective of the development of the public open space and roads; secondly, the resort complex; and lastly, the residential dwellings. Concurrent development will be permitted if the primary objective is being satisfied.
- The Specific Plan contains a Phasing Plan which provides for the development of Sea Terrace Park as the first phase of development. The resort complex and residential dwellings will be build concurrently or subsequent to the completion of the Park. Concurrent development is assumed in the Specific Plan and satisfies the primary objective.

See comment 26

**GENERAL PLAN POLICIES**

**SPECIFIC PLAN CONFORMANCE  
WITH GENERAL PLAN**

**Land Use Element (Cont.)**

- 9.1 Develop regulations to protect and encourage local serving retail and office use adjacent to residential areas.
- 9.2 Encourage a full range of resident-serving land uses throughout the City to meet resident needs.
- 9.3 Encourage resident-serving uses within walking distance of residents, where possible.

The Specific Plan encourages the use of the retail and restaurant facilities in the resort by the community, through the integration of residential uses within the resort community and the public access program.

The VRC and Recreation Open Space land uses in the Specific Plan are intended for the use of City residents as well as visitors to the City. Sea Terrace Community Park is intended to be primarily for the use of City residents.

The pedestrian trails shown in the Specific Plan are intended to provide access to a variety of uses for residents within walking distance of the site. The integrated resort community concept of cohesive hotel, recreation, and residential uses promotes this policy.

**Urban Design Element**

- 1.1 Develop citywide linkages through landscaping and lighting along major street corridors. (Coastal Act/30251)
- 1.2 Improve the visual character of major street corridors.
- 1.3 Make focused improvements at major City entrance points such as landscaped open space and signage.
- 1.4 Preserve public views from streets and public places. (Coastal Act/30251)

The Specific Plan provides for project landscaping and lighting which, when linked to that of surrounding areas, fulfills this policy requirement.

The Landscape Concept Plan and policies are intended to help improve the visual character of Niguel Road, Pacific Coast Highway, and Camino Del Avion.

The Landscape Concept Plan and policies provide for focused improvements at the entrances of the Specific Plan area at PCH and Niguel Road.

Public views from streets adjacent to the site are being protected along PCH and Niguel Road, and Camino del Avion. In addition, vista points, promenades, etc. are planned to provide additional public viewing areas on-site.



**GENERAL PLAN POLICIES**

**SPECIFIC PLAN CONFORMANCE  
WITH GENERAL PLAN**

Urban Design Element (Cont.)

- |                |  |   |
|----------------|--|---|
| 1.5            | Develop the Bluff Top Walk from Monarch Beach to Doheny State Park.  | This policy is not applicable as the Bluff Top Walk is not within or adjacent to this Specific Plan area.   |
| 1.6            | Develop a citywide public signage system with identity and directional graphics to mark public places, recreational opportunities and principal attractions. | The Specific Plan reflects the intent of this policy by providing for the development of a detailed sign program.   |
| 1.7            | Initiate a program for public art.   | This Specific Plan provides for the inclusion of public art within the Specific Plan area.  |
| 2.1            | Consider the distinct architectural and landscape character of each community.   | The Community Design and Landscape Guidelines provide for a unique, high quality architectural and landscape character of the Monarch Beach Resort that is compatible with and enhances the surrounding community.  |
| 2.2            | Adopt development standards and design guidelines for commercial areas that reflect the individual character of each community.                              | The Community Design Guidelines and Development Standards for resort facilities will create a world-class quality character that is appropriate to the setting of the Monarch Beach community.  |
| See comment 27 |  |   |
| 2.3            | Improve public places and recreational facilities as focus points for each community. (Coastal Act/30213)  | Land will be dedicated, improved and maintained for park and public open space features to further define the character of the Monarch Beach area and to provide facilities for local community use.  |
| 2.4            | Establish a program to preserve buildings and sites of historical and architectural significance.  | This policy is not applicable as there are no historically or architecturally significant buildings or sites within the Specific Plan area.   |
| 2.5            | Encourage neighborhood street landscaping programs to improve the quality of public spaces in residential areas.   | The Landscape Guidelines Concept Plan delineates neighborhood street landscaping programs to ensure the high quality of open space areas within the residential areas. The landscape guidelines provide for integrated design of all areas of the resort. |

## GENERAL PLAN POLICIES

## SPECIFIC PLAN CONFORMANCE WITH GENERAL PLAN

### Urban Design Element (Cont.)

- |     |   |   |
|-----|---|---|
| 3.1 | Increase the Town Center's economic vitality and its contribution to the City's economic development goals.   | This policy is not applicable as the Town Center is not within or adjacent to this Specific Plan area.      |
| 3.2 | Reduce the disruptive and negative impact of traffic movements and high traffic speeds in the Town Center.  | This policy is not applicable as the Town Center is not within or adjacent to this Specific Plan area.      |
| 3.3 | Improve pedestrian opportunities and create an attractive pedestrian environment within the Town Center. (Coastal Act/30250)  | This policy is not applicable as the Town Center is not within or adjacent to this Specific Plan area.      |
| 3.4 | Encourage mixed-use development in selected areas of the Town Center.   | This policy is not applicable as the Town Center is not within or adjacent to this Specific Plan area.      |
| 3.5 | Develop a parking concept that emphasizes shared parking facilities.  | This policy is not applicable as the Town Center is not within or adjacent to this Specific Plan area.      |
| 3.6 | Create safety buffers of street trees, planters and street furniture between pedestrian walks and the street along both the Pacific Coast Highway and Del Prado. Provide widened sidewalks with a special Town Center streetscape design. | This policy is not applicable as the Town Center is not within or adjacent to this Specific Plan area.      |
| 3.7 | Develop pedestrian courtyards and other outdoor spaces with planting and street furniture.  | This policy is not applicable as the Town Center is not within or adjacent to this Specific Plan area.      |
| 3.8 | Encourage pedestrian-oriented building frontages with shops opening to the public sidewalk.   | This policy is not applicable as the Town Center is not within or adjacent to this Specific Plan area.      |
| 4.1 | Create a new Civic Center as a focus point of the City.   | This policy is not applicable within the Specific Plan area.  |
| 4.2 | Realize the opportunity for public open space throughout the City.  | A significant proportion of the Specific Plan area is set aside for public open space and recreational use. |

## GENERAL PLAN POLICIES

## SPECIFIC PLAN CONFORMANCE WITH GENERAL PLAN

### Urban Design Element (Cont.)

- |     |  |  |
|-----|--|--|
| 4.3 | Develop stronger pedestrian, bicycle and visual linkages between public spaces. (Coastal Act/30210, 30212)   | The Trails Plan and Park Concept Plan provide a comprehensive pedestrian, bicycle and visual linkages between public spaces within the Specific Plan and surrounding areas.  |
| 4.4 | Encourage development of community cultural and recreational facilities. (Coastal Act/30213)   | The Park and Open Space Concept Plan provides for the development of community, cultural and recreational facilities.  |
| 4.5 | Protect existing public views to the ocean from the Coast Highway and selected public sites along the Blufftop trail and Capistrano Beach bluffs through open space designations and innovative design techniques. (Coastal Act/30251) | The Specific Plan provides for the protection of existing public views to the ocean from Coast Highway. The Blufftop trail and Capistrano Beach bluff are not within or adjacent to this Specific Plan area.   |
| 5.1 | Adopt comprehensive Design Guidelines for the review of all new non-residential and multi-family development in the City.  | The Urban Design Guidelines provide policies and exhibits by which to review all new non-residential and multi-family development in the City.   |
| 5.2 | Encourage site and building design that takes advantage of the City's excellent climate to maximize indoor-outdoor spatial relationships. (Coastal Act/30250).   | The Urban Design Guidelines provide for the development of site and building design that takes advantage of the City's excellent climate to maximize indoor-outdoor spatial relationships. The utilization of Tuscan architectural themes is an appropriate response to this policy.   |
| 5.3 | Encourage buildings and exterior spaces that are carefully scaled in all new development.  | The Urban Design Guidelines and Development Standards provide for the development of buildings and exterior spaces that are carefully scaled. With respect to heights and massing, the hotel development standards provide view protection for adjacent residents and residential development is massed to respond to hillside conditions and to promote the project Tuscan theme. |
| 5.4 | Provide outdoor pedestrian spaces, sidewalks, and usable open space in all new development.  | The Specific Plan provides for a myriad of outdoor pedestrian spaces, sidewalks and useable open space to be included in the new resort community, including the hotel gardens, the Crescent Promenade, and expanded golf course.  |

**GENERAL PLAN POLICIES**

**SPECIFIC PLAN CONFORMANCE  
WITH GENERAL PLAN**

Urban Design Element (Cont.)

- |     |  |  |
|-----|--|--|
| 5.5 | Promote extensive landscaping in all new projects while emphasizing the use of drought-tolerant plant materials.                 | The Specific Plan delineates extensive landscaping for the project area and provides for the use of drought tolerant plant materials where feasible. Reclaimed water will be used for irrigation of landscaped areas, where possible throughout the Specific Plan area, including the golf course. |
| 5.6 | Encourage aesthetic roof treatment as an important architectural design feature.   | The Specific Plan includes guidelines which provide for the use of aesthetic roof treatment as an important architectural design feature of the resort community.  |
| 6.1 | Improve The Pacific Coast Highway and Doheny Park Road as major entrance boulevards to the City.                                 | This policy is not applicable as Doheny Village is not within or adjacent to this Specific Plan area.  |
| 6.2 | Unify new commercial development through design concepts for consistent building setbacks, landscaping architecture and signage. | This policy is not applicable as Doheny Village is not within or adjacent to this Specific Plan area.  |
| 6.3 | Increase Doheny Village's economic vitality and its contribution to the City's economic development goals.                       | This policy is not applicable as Doheny Village is not within or adjacent to this Specific Plan area.  |
| 6.4 | Reduce the disruptive and negative impact of traffic movements and high traffic speeds in the Doheney Village area.              | This policy is not applicable as Doheny Village is not within or adjacent to this Specific Plan area.  |
| 6.5 | Improve pedestrian opportunities and create an attractive pedestrian environment within Doheny Village. (Coastal Act/30250)      | This policy is not applicable as Doheny Village is not within or adjacent to this Specific Plan area.  |
| 6.6 | Encourage mixed-used development in selected areas of Doheny Village.  | This policy is not applicable as Doheny Village is not within or adjacent to this Specific Plan area.  |
| 6.7 | Develop a parking concept that emphasizes shared parking facilities.   | This policy is not applicable as Doheny Village is not within or adjacent to this Specific Plan area.  |

## GENERAL PLAN POLICIES

## SPECIFIC PLAN CONFORMANCE WITH GENERAL PLAN

### Urban Design Element (Cont.)

- 7.1 Develop design concepts to address marine and light industrial activities. (Coastal Act/30260)
- 7.2 Develop urban design guidelines for open space areas to insure the protection and display of natural resources.
- 7.3 Encourage design concepts to incorporate the City's coastal influence into site and building design.

This policy is not applicable as no marine or light industrial activities are planned for this Specific Plan area.

The Specific Plan reflects the Resource Enhancement program by stipulating design guidelines for enhancement of coastal sage scrub habitat in conjunction with the golf course, regional trails system and vista point at Camino del Avion.

The guidelines in this Specific Plan provide for the incorporation of the City's coastal influence into site and building design. The Tuscan architectural theme is an appropriate response to the coastal character of the City.

### Housing Element

- 1.1 Provide a variety of housing opportunities for all income levels of the City.
- 1.2 Support innovative public, private and non-profit efforts in the development and financing of affordable housing, particularly for lower income households, the elderly, large families, the physically impaired, and single parent households.

The residential element of the plan will result in the production of 238 residential units. It is projected that these dwellings will contribute to meeting a portion of the "above moderate income" housing needs as projected by the Southern California Association of Governments for the following two periods: 1989-1994 and 1994-1999.

Innovative initiatives is an integral aspect of the comprehensive planning for Monarch Beach Resort. The Specific Plan endorses the creation of a Housing Trust Fund and other programs.

## GENERAL PLAN POLICIES

## SPECIFIC PLAN CONFORMANCE WITH GENERAL PLAN

### Housing Element Policies (Cont.)

- |      |   |  |
|------|---|--|
| 1.14 | Consider requirements for providing affordable housing for employees of hotel and resort developments. (Coastal Act/30213)  | The Specific Plan provides initiatives to address employee housing needs.  |
| 1.15 | Provide for mixed commercial/residential land uses to create additional housing opportunities.  | There are no mixed use zones in the Specific Plan area.  |
| 1.16 | Consider flexibility in development standards to allow for single room occupancy facilities for low income individuals. (Coastal Act/30213)   | There are no single room occupancy facilities proposed in the Specific Plan.   |
| 1.17 | Evaluate housing cost increases resulting from any new City requirements.   | This is an initiative directed primarily to City staff.  |
| 2.1  | Support a code enforcement program to help maintain the physical condition and appearance of neighborhood areas.  | This is not within the scope of the Specific Plan. This will be addressed at subsequent levels of planning.                              |
| 2.2  | Provide neighborhood conservation and residential rehabilitation programs which offer financial and technical assistance to owners of lower income housing property to enable correction of housing deficiencies. | This policy is not applicable as there are no existing neighborhoods to conserve or rehabilitate.  |
| 2.3  | Provide adequate standards for remodeling and expanding existing dwellings to ensure compliance with minimum State and Uniform Building Codes.  | This policy is not applicable as there are no existing dwellings on-site to remodel or expand.   |
| 2.4  | Minimize the displacement impacts occurring as a result of residential demolition.  | This Specific Plan has no displacement impact as a result of residential demolition, as there are no existing residential units on site. |

## GENERAL PLAN POLICIES

## SPECIFIC PLAN CONFORMANCE WITH GENERAL PLAN

### Circulation Element (Cont.)

- |      |   |   |
|------|---|---|
| 1.9  | Limit driveway access on arterial streets to maintain a desired quality of flow.  | The Specific Plan provides limited driveway access on Niguel Road and Pacific Coast Highway to maintain the desired quality of flow along those arterial streets.                     |
| 1.10 | Design local and collector streets to discourage their use as through traffic routes.   | The private residential streets will be gated discouraging their use as through traffic routing.  |
| 1.11 | Require that proposals for major new developments include a future traffic impact analysis which identifies measures to mitigate any identified project impacts. (Coastal Act/30250)        | The Mitigated Negative Declaration for the Specific Plan includes a future traffic impact analysis which identifies measures to mitigate any identified project impacts.              |
| 1.12 | Encourage new development which facilitate transit services, provides for non-automobile circulation and minimizes vehicle miles traveled. (Coastal Act/30252)                              | The Specific Plan provides pedestrian and bicycle trails and a resort vehicle system to provide for non-automobile circulation, minimizes vehicle miles traveled, and coastal access. |
| 1.13 | Minimize pedestrian and vehicular conflicts. (Coastal Act/30252)  | The Specific Plan provides for a variety of off-street pedestrian and bicycle trails to minimize conflicts with vehicular traffic.  |
| 1.14 | Establish landscaping buffers and building setback requirements along all roads where appropriate. (Coastal Act/30252)  | The Specific Plan establishes landscaping buffers and building setback requirements along all roads.  |
| 1.15 | Develop a circulation system which highlights environmental amenities and scenic areas. (Coastal Act/30251)   | A network of trails and a resort vehicle system provide for public access to the environmental amenities and scenic areas of the Specific Plan.                                       |
| 1.16 | Provide public access and circulation to the shoreline through private dedications, easements, or other methods including public transportation. (Coastal Act/30211, 30212, 30212.5, 30221) | The Specific Plan provides public access and circulation to the shoreline via public trails, a resort vehicle system and the Beach House VRC.   |

## GENERAL PLAN POLICIES

## SPECIFIC PLAN CONFORMANCE WITH GENERAL PLAN

### Circulation Element (Cont.)

- |     |   |   |
|-----|---|---|
| 3.1 | Implement traffic signal coordination on arterial streets to the maximum extent practical, and integrate signal coordination efforts with those of adjacent jurisdictions.  | This is a City-wide policy.   |
| 3.2 | Implement intersection capacity improvements where feasible.  | The Specific Plan provides for the implementation of intersection capacity improvements.  |
| 3.3 | Encourage the implementation of employer Transportation Demand Management (TDM) requirements included in the Southern California Air Quality Management District's Regulation 15 of the Air Quality Management Plan. Participate in regional efforts to implement (TDM) requirements. | This policy is not applicable in the Specific Plan.   |
| 3.4 | Require that proposals for major new non-residential developments (in excess of 50,000 square feet) include submission of a TDM plan to the City, including monitoring and enforcement provisions. (Coastal Act/30213)  | The Specific Plan Environmental Documentation provides for the submission of a TDM plan to the City, including monitoring and enforcement provisions. |
| 3.5 | Encourage the development of additional regional public transportation services and support facilities including park-and-ride lots near the I-5 freeway.   | The Specific Plan provides for the improvements to the bus where turnout on PCH at Niguel Road.   |
| 3.6 | Promote ridesharing through publicity and provision of information to the public.   | This Specific Plan encourages ridesharing for the Hotel employees.  |
| 4.1 | Support the efforts of the appropriate agencies to provide additional local and express bus service to the Dana Point community, and to provide additional park-and-ride lots near I-5 freeway.   | This is a City-wide policy and the Specific Plan does not discourage this.  |



## GENERAL PLAN POLICIES

## SPECIFIC PLAN CONFORMANCE WITH GENERAL PLAN

### Circulation Element (Cont.)

- |     |  |   |
|-----|--|---|
| 4.2 | Require new development to fund transit facilities, such as bus shelters and turn-outs, where deemed necessary.  | The Specific Plan provides for improvements to a bus shelter and bus turnouts.  |
| 4.3 | Ensure accessibility of public transportation for elderly and disabled persons.  | The Specific Plan provides for accessibility of public transportation for elderly and disabled persons through the design of the public trails that link with the bus stop.   |
| 4.4 | Encourage employers to reduce vehicular trips by offering employee incentives.   | This is a City-wide policy and the TDM requirements, to be developed by the employer, will address trip reduction.  |
| 4.5 | Promote new development that is designed in a manner which (1) facilitates provision or expansion of transit service, (2) provides on-site commercial and recreational facilities to discourage mid-day travel, and (3) provides non-automobile circulation within the development. (Coastal Act/30213, 30252) | The Specific Plan creates a development that (1) encourages the use of transit services, (2) provides recreational facilities and visitor serving facilities which discourage mid-day travel, and (3) provides non-automobile circulation within the development. |
| 4.6 | Encourage developers to work with agencies with the objective of maximizing the potential providing transit service for transit use by residents and/or visitors.  | The developer has worked with agencies with the objective of maximizing the potential of providing transit service for transit use by residents and/or visitors, as provided in the public access and trails programs.  |
| 4.7 | Encourage the provision of safe, attractive and clearly identifiable transit stops and related high quality and pedestrian facilities throughout the community. (Coastal Act/30252)  | The Specific Plan provides for safe, attractive and clearly identifiable transit stops and related high quality and pedestrian facilities throughout the resort community.  |

## GENERAL PLAN POLICIES

## SPECIFIC PLAN CONFORMANCE WITH GENERAL PLAN

### Circulation Element (Cont.)

- |     |   |   |
|-----|---|---|
| 4.8 | Require noise impact studies prior to approval of new public transportation routes through residential communities.   | This policy is not applicable as no new public transportation routes through residential communities are planned in the Specific Plan.  |
| 5.1 | Promote the safety of pedestrians and bicyclists by adhering to uniform standards and practices.  | The Specific Plan promotes safety of pedestrians and bicyclists by adhering to uniform standards and practices.   |
| 5.2 | Maintain existing pedestrian facilities and encourage new development to provide pedestrian walkways between developments, schools and public facilities.   | The Specific Plan provides for a variety of pedestrian trails that link with City trails, and public facilities.  |
| 5.3 | Ensure accessibility of pedestrian facilities to the elderly and disabled.  | This Specific Plan provides for the accessibility of pedestrian facilities to the elderly and disabled through adherence to standard barrier-free design criteria.  |
| 5.4 | Support and coordinate the development and maintenance of bikeways in conjunction with the County of Orange Master Plan of County-wide Bikeways to assure that local bicycle routes will be compatible with routes of neighboring jurisdictions.                    | This Specific Plan reflects the support and coordination of the bikeway in conjunction with the County of Orange Master Plan of County-wide Bikeways to assure that local bicycle routes will be compatible with routes of neighboring jurisdictions. |
| 5.5 | Encourage the provision of showers, changing rooms and an accessible and secure area for bicycle storage at all new and existing developments and public places. (Coastal Act/30213)  | The Specific Plan provides for restrooms and bike storage in Sea Terrace Community Park.  |
| 5.6 | Develop programs that encourage the safe utilization of easements and/or rights-of-way along flood control channels, public utility rights-of-way, railroad rights-of-way, and street rights-of-way wherever possible for the use of bicycles and/or hiking trails. | Where possible, the Specific Plan utilizes easements surrounding the golf course area, where appropriate, for pedestrian trails.  |

## GENERAL PLAN POLICIES

## SPECIFIC PLAN CONFORMANCE WITH GENERAL PLAN

### Circulation Element (Cont.)

- |      |  |   |
|------|--|---|
| 5.7  | Explore possible link-up of trails within the city to regional trail systems.  | The Specific Plan provides for the link-ups of trails within the city to regional trail systems by design and through the policy encouraging utilization of Coastal Access funds.                             |
| 5.8  | Improve the safety of pedestrians crossing Pacific Coast Highway. (Coastal Act/30252)  | This Specific Plan provides for the public use of two tunnels under Pacific Coast Highway by pedestrians and bicyclists to maximize safety of crossing Pacific Coast Highway.                                 |
| 5.9  | Support and coordinate the development and maintenance of bikeways and trails in conjunction with the master plans of the appropriate agencies.            | This Specific Plan reflects the support and coordination of the level of maintenance of bikeways and trails in conjunction with the County HBP and Capistrano Beach Park and Recreation District Master Plan. |
| 5.10 | Encourage safe biking by supporting the clinics sponsored by the County Sheriff's Department.  | This policy is of City-wide application.  |
| 5.11 | Consider the provision of unique non-motorized circulation methods for special events.   | The Specific Plan provides the resort vehicle system to meet these needs.   |
| 5.12 | Provide for a non-vehicular circulation system that encourages mass-transit, bicycle transportation and pedestrian circulation. (Coastal Act/30252, 30253) | The Specific Plan provides for pedestrian trails, bikeways, resort vehicle system and bus shelters which encourage the use of mass-transit, bicycle transportation and pedestrian circulation.                |
| 6.1  | Consolidate parking, where appropriate, to eliminate the number of ingress and egress points onto arterials.   | The Specific Plan provides for the consolidation of parking at the Hotel and Golf Clubhouse.  |
| 6.2  | Maintain public access to the coast by providing better transit and parking opportunities. (Coastal Act/30252)   | The maintenance of public access to the coast is reflected in this Specific Plan through the provision of numerous trails and the resort vehicle system.  |

## GENERAL PLAN POLICIES

## SPECIFIC PLAN CONFORMANCE WITH GENERAL PLAN

### Circulation Element (Cont.)

- |     |   |  |
|-----|---|--|
| 6.3 | Provide sufficient off-street parking. (Coastal Act/30250)  | The Specific Plan provides for sufficient off-street parking as delineated in the parking standards.   |
| 6.4 | Encourage the use of shared parking facilities, by means of parking districts or other mechanisms.                              | The Specific Plan provides for the use of shared parking facilities at the golf course clubhouse.  |
| 7.1 | Provide primary truck routes on selected arterial streets to minimize the impacts of truck traffic on residential areas.        | The Specific Plan reflects the provision of primary truck routes on PCH & Niguel Road to minimize the impacts of truck traffic on residential areas.                                       |
| 7.2 | Provide appropriately designed and maintained roadways for the primary truck routes. (Coastal Act/30254)                        | This policy is primarily applicable to City staff. However, improvements to PCH in the Specific Plan area will be consistent with this policy.   |
| 7.3 | Develop berms, landscape screening or barriers along truck routes to minimize noise impacts on sensitive land uses.             | The use of landscape and architectural barriers is provided for in this Specific Plan along PCH & Niguel Road to minimize noise impacts on sensitive land uses.                            |
| 7.4 | Provide loading areas and accessways that are designed and located so as to avoid conflicts with efficient traffic circulation. | This Specific Plan provides for loading areas on-site at the hotel and clubhouse and accessways that are designed and located so as to avoid conflicts with efficient traffic circulation. |
| 7.5 | Consider safety regulations addressing trucks hauling materials within the city.  | This policy is of citywide application.  |
| 8.1 | Evaluate the adequacy of and maintain sufficient capacity within the Harbor for the existing and future patrons of the Harbor.  | This policy is not applicable as the Harbor is not within or adjacent to this Specific Plan area.  |

**GENERAL PLAN POLICIES**

**SPECIFIC PLAN CONFORMANCE  
WITH GENERAL PLAN**

**Circulation Element (Cont.)**

- |      |   |  |
|------|---|--|
| 9.1  | Coordinate with Amtrak and Los Angeles-San Diego (LOSSAN) Corridor Commuter Rail to expedite commuter rail service to the City.   | This policy is not applicable as rail service is a regional issue and is not provided to the Specific Plan area. |
| 9.2  | Work with the appropriate entities to evaluate development of a commuter rail station for Dana Point, with shuttle connections to employment centers and residential areas. | This is a City-wide policy.  |
| 10.1 | Work with the Orange County Transit District (OCTD) and other appropriate agencies to provide express transportation to regional airports.                                  | This is a City-wide policy.  |

**Noise Element**

- |     |  |   |
|-----|--|---|
| 1.1 | Require construction of barriers to mitigate sound emissions where necessary or feasible.                        | This Specific Plan requires the use of noise insulation materials and techniques, and site planning to mitigate sound emissions where necessary and feasible, particularly along Pacific Coast Highway and Niguel Road. |
| 1.2 | Ensure the inclusion of noise mitigation measures in the design of new roadway projects in Dana Point.           | The Specific Plan provides for the inclusion of noise mitigation measures in the design of new roadway projects in the project area.  |
| 1.3 | Reduce transportation noise through proper design and coordination of transportation facilities and circulation. | This policy is not applicable as it is directed specifically to City staff.   |

**GENERAL PLAN POLICIES**

**SPECIFIC PLAN CONFORMANCE  
WITH GENERAL PLAN**

**Noise Element (Cont.)**

- |     |  |  |
|-----|--|--|
| 1.4 | Ensure the effective enforcement of City, State and Federal noise levels by all appropriate City staff.  | This policy is not applicable as it is directed specifically to City Staff.  |
| 1.5 | Monitor noise from buses and other vehicular types in residential areas, and, when necessary, consider alternative circulation routes for those types of vehicles. | Residential roads will be gated and private. Vehicle traffic will be controlled.   |
| 1.6 | Coordinate noise complaints on aircraft overflights with the appropriate governmental agency.  | This policy is of City-wide application.   |
| 2.1 | Establish acceptable limits of noise for various land uses throughout the community, in accordance with Table N-2.   | This is the responsibility of the City. The Specific Plan provides guidelines to accomplish this in accord with state law.   |
| 2.2 | Ensure acceptable noise levels near schools, hospitals, convalescent homes, and other noise sensitive areas, in accordance with Table N-1.                         | This policy is not applicable as no schools, hospitals, convalescent homes or other noise sensitive areas addressed in Table N-1 in the General Plan are planned for this Specific Plan. |
| 2.3 | Establish standards for all types of noise not already governed by local ordinances or preempted by state or federal law.  | The Specific Plan provides guidelines to accomplish this in accord with state law.   |
| 2.4 | Require noise reduction techniques in site and architectural design and construction where noise reduction is necessary.   | The Specific Plan provides guidelines to accomplish this in accord with state law.   |
| 2.5 | Discourage locating noise sensitive land uses in noisy environments.   | Residential development will be appropriately set back and buffered from arterial roadways.  |

## GENERAL PLAN POLICIES

## SPECIFIC PLAN CONFORMANCE WITH GENERAL PLAN

### Noise Element (Cont.)

- |     |   |   |
|-----|---|---|
| 3.1 | Adopt a City Noise Ordinance to control excessive noise from lawn blowers, trimmers, machinery or other disturbances. This ordinance should be consistent with the Orange County Noise Ordinance to promote mutually enforceable standards which result in a quality noise environment. | This policy is not applicable as it is to implemented by City staff.    |
| 3.2 | Evaluate and develop measures to reduce noise generated by construction activities.   | This policy is not applicable as it is to be implemented by City staff. |
| 3.3 | Establish and maintain coordination among the appropriate agencies involved in noise abatement.   | This policy is not applicable as it is to be implemented by City staff. |

### Public Safety Element

- |     |  |   |
|-----|--|---|
| 1.1 | Require review of soil and geologic conditions by a State-Licensed Engineering Geologist under contract to the City, to determine stability prior to the approval of development where appropriate. (Coastal Act/30250, 30253) | The Specific Plan provides for the review of soil and geological conditions by state-licensed engineering geologist under contract to the City.   |
| 1.2 | Monitor and document known and potential geologic hazards in the city.   | The Specific Plan area does not have any known or potential geologic hazards. Structures will be designed and soils engineering will be completed to mitigate any problems posed by expansive soils on-site. The Preliminary Geotechnical Report will document all findings and requirements. |
| 1.3 | Adopt standards and requirements for grading and construction to mitigate the potential for bluff failure and seismic hazards.   | The Specific Plan adopts standards and requirements for grading and construction.   |
| 1.4 | Provide for structural setbacks from the bluff top edges based upon recommendations by a State-Licensed Engineering Geologist.   | The beach house will be designed to assure geological stability and protection.   |

**GENERAL PLAN POLICIES**

**SPECIFIC PLAN CONFORMANCE  
WITH GENERAL PLAN**

**Public Safety Element (Cont.)**

- |      |   |   |
|------|---|---|
| 1.5  | Adopt blufftop setback requirements based upon the severity of the conditions. The minimum 25-foot blufftop structural setbacks mandated by the Coastal Act may be inadequate.  | The beach house will be designed to assure geological stability and protection.   |
| 1.6  | Prevent future development or redevelopment of bluff top properties that may pose a hazard to owners, occupants, property, and the general public.  | The beach house will be designed to assure geological stability and protection.   |
| 1.7  | Preserve Dana Point's bluffs as a natural resource and avoid risk to life and property through responsible and sensitive Bluff top development.   | The beach house will be designed to assure geological stability and protection.   |
| 1.8  | Encourage development which utilizes the desirable existing features of land such as natural vegetation, geologic features, and other features which preserve the site's significant identity.  | The Landscape Plan and the Resource Management Program provides for the establishment of significant new areas of native plant communities. |
| 1.9  | New bluff top development should be designed and located so as to ensure geological stability and to eliminate erosion, or destruction of the site or surround area.  | The beach house will be designed to assure geological stability and protection.   |
| 1.10 | Bluff repair and erosion control measures such as retaining walls and other similar devices should be limited to those necessary to repair damage to the bluff face and should avoid causing significant alteration to the natural character of the bluffs. | This policy is not directly applicable to the Specific Plan.<br><br>See comment 28  |



## GENERAL PLAN POLICIES

## SPECIFIC PLAN CONFORMANCE WITH GENERAL PLAN

### Public Safety Element (Cont.)

- |      |   |   |
|------|---|---|
| 1.11 | Design of coastal protection devices that account for the factors exceeding the limits of previously recorded storms, elevated storm surges and spring tide conditions.                             | This policy is not directly applicable to the Specific Plan.  |
| 1.12 | Specifically review and limit development on lands with seismic, slide, liquefaction, fire or topographic constraints.  | The Preliminary Geotechnical Report required for site/coastal development permits on-site will identify any constraints to development and propose mitigations. |
| 1.13 | Encourage a periodic sand nourishment program to replenish, widen and stabilize the beach where necessary.  | This policy is not applicable as there are no beaches within the Specific Plan area.  |
| 1.14 | Consider the establishment of Geologic Hazard Abatement Districts to encourage local cooperation in preventing coastal hazards and to access State, local, and federal subsidies where appropriate. | This policy is not applicable as there is no need for the establishment of geologic hazard abatement districts in the Specific Plan area.                       |
| 1.15 | Construct sea walls only as a last resort protective device for coastal areas.  | No sea walls are planned as part of the Specific Plan   |
| 1.16 | Investigate means to improve the quality of Dana Point Harbor dredge sediment so that it can be used in sand replenishment programs.  | This policy is not applicable as the Dana Point Harbor is not within or adjacent to this Specific Plan area.  |
| 1.17 | Support and encourage the effects of Orange County Flood Control District to modify the San Juan Creek Channel in order to increase sediment yield to the Capistrano and Doheny Beach areas.        | This policy is not applicable as the San Juan Creek Channel is not within or adjacent to this Specific Plan area.   |

## GENERAL PLAN POLICIES

## SPECIFIC PLAN CONFORMANCE WITH GENERAL PLAN

### Public Safety Element (Cont.)

- |      |  |  |
|------|--|--|
| 1.18 | If dredge sediment from Dana Point Harbor cannot be made usable in the immediate future, support and assist Capistrano Bay property owners in the formulation of a Geologic Hazard Abatement District to address the financing of alternative methods for sand replenishment of the beach areas. | This policy is not applicable as the Dana Point Harbor and Capistrano Bay are not within or adjacent to this Specific Plan area. |
| 1.19 | Assure that public safety is provided for in all new seaward construction or additions to existing single family structures within the Capistrano Bay District private community.  | This policy is not applicable as Capistrano Bay is not within or adjacent to this Specific Plan area.                            |
| 1.20 | Inventory existing structures and identify those which are seismically unsound. Require correction of seismically unsound buildings or as a last resort required removal dangerous buildings.  | This policy is not applicable as there are no existing permanent structures within the Specific Plan area.                       |
| 1.21 | Adopt and maintain accepted State standards for seismic performance of new building.   | Final site plans and construction documents will reflect the State standards for seismic performance of new building.            |
| 1.22 | Promote earthquake preparedness within the community by participation in periodic earthquake awareness programs.   | This policy is of citywide application.  |
| 1.23 | Include and periodically review and update emergency procedures for earthquake in the City's Emergency Operations Plan.  | This policy is of citywide application.  |

## GENERAL PLAN POLICIES

## SPECIFIC PLAN CONFORMANCE WITH GENERAL PLAN

### Public Safety Element (Cont.)

- |      |   |  |
|------|---|--|
| 1.24 | Coordinate with County of Orange, Atchison, Topeka, and Santa Fe Railroad and Caltrans to identify and correct any structural deficiencies of bridges and overpasses.                           | This policy is of citywide application.  |
| 2.1  | Identify flood hazard areas and provide appropriate land use regulations for areas subject to flooding.   | Flood hazard areas have been identified and only recreation and open space land uses are planned for these areas.                                    |
| 2.2  | Regulate the construction of non-recreational uses on coastal stretches with high predicted storm wave run-up to minimize risk of property damage.  | This policy is not applicable to the Specific Plan.  |
| 2.3  | Coordinate with the appropriate agencies to prepare and maintain a master drainage plan.  | The Specific Plan provides a master plan of drainage. Detailed drainage improvements will be specified in the site/coastal development permit plans. |
| 2.4  | Coordinate with the appropriate agencies to assure that existing bridges are constructed according to the standards to avoid damage by flooding.  | This policy is not applicable to the Specific Plan area.   |
| 2.5  | Continue to participate in the national flood insurance program.  | This policy is not applicable to the Specific Plan area.   |
| 2.6  | Cooperate with the Orange County Flood Control District to plan for and make needed improvements or modifications to San Juan Creek Channel to enable it to carry runoff from a 100 year storm. | This policy is not applicable as the San Juan Creek Channel is not within or adjacent to this Specific Plan area.                                    |

**GENERAL PLAN POLICIES**

**SPECIFIC PLAN CONFORMANCE  
WITH GENERAL PLAN**

**Public Safety Element (Cont.)**

- |     |   |  |
|-----|---|--|
| 2.7 | Cooperate with the Orange County Flood Control District to plan for and correct the potential for overflow from the underground Capistrano Beach Storm Drain to relieve the potential for flooding in the Doheny Village area. Until this is accomplished, encourage affected residents and businesses to purchase federal flood insurance. | This policy is not applicable as neither the Capistrano Beach storm drain nor the Doheny Village area are within or adjacent to this Specific Plan area. |
| 2.8 | Require detention basins where applicable to reduce the risk from flood hazards.  | The Specific Plan area does not require detention basins.  |
| 3.1 | Cooperate with the County to implement applicable portions of the County's proposed Hazardous Waste Management Plan.  | This policy is of City-wide application.   |
| 3.2 | Cooperate with railroad operations to ensure that hazardous materials transported by rail do not pose a threat to life or property.   | This policy is not applicable as there are no railroad operations anticipated as a result of the development of this project.                            |
| 3.3 | Establish regulations requiring land uses involved in the production, storage, transportation, handling, or disposal of hazardous materials be located a safe distance from other land uses that may be adversely affected by such activities.  | This policy is of citywide application.  |

**GENERAL PLAN POLICIES**

**SPECIFIC PLAN CONFORMANCE  
WITH GENERAL PLAN**

**Public Safety Element (Cont.)**

- |      |  |   |
|------|--|---|
| 3.10 | Support efforts to enforce State "right to know" laws, which outline the public's right to information about local toxics producers.           | This policy is of City-wide application.  |
| 3.11 | Establish development standards for storage of industrial chemicals and other potentially hazardous substances.                                | This policy is of City-wide application.  |
| 3.12 | Coordinate with the County of Orange in the implementation of the National Pollution Discharge Elimination System Permits (NPDES) regulations. | This policy is of City-wide application.  |
| 4.1  | Work closely with the County of Orange to establish an education program regarding fire hazards.   | This policy is not applicable to the Specific Plan area as it is directed to City staff.  |
| 4.2  | Establish requirements for fire-resistant roofing materials.   | Fire-resistant roofing materials will be used throughout the Specific Plan area.  |
| 4.3  | Establish a program to provide notice to all residents located in areas that may have higher risks of fire hazards.                            | This policy is of City-wide application.  |
| 4.4  | Establish and maintain mutual aid agreements with surrounding cities for fire protection.  | This policy is not applicable to the Specific Plan area as it is a city policy.   |
| 4.5  | Encourage building code requirements that assure adequate fire protection.   | The Specific Plan development standards provide for the employment of prevailing building code requirements that assure adequate fire protection. |

## GENERAL PLAN POLICIES

## SPECIFIC PLAN CONFORMANCE WITH GENERAL PLAN

### Conservation/Open Space

- |     |  |  |
|-----|--|--|
| 1.1 | Retain and enhance local drainage courses, channels, and creeks in their natural condition, where feasible and desirable. (Coastal Act/30235, 30236)   | This Specific Plan provides for the retention and partial enhancement of Salt Creek banks.   |
| 1.2 | Protect groundwater resources from depletion and sources of pollution.   | The Specific Plan provides for the protection of the water resources contained within the Salt Creek Channel through proper management of the adjacent golf course and erosion control measures.   |
| 1.3 | Conserve imported water by providing water conservation techniques, and using reclaimed water, water conserving appliances, and drought-resistant landscaping when feasible.   | The Specific Plan Water Conservation Plan encourages the conservation of imported water by providing for the use of reclaimed water for all landscaped areas including the golf course. Drought tolerant landscaping is provided within the upper Salt Creek area.                             |
| 1.4 | Protect water quality by seeking strict quality standards and enforcement with regard to water imported into the County, and the preservation of the quality of water in the groundwater basin, streams, estuaries, and the ocean. (Coastal Act/30231) | The Specific Plan protects water quality by providing standards to protect the Salt Creek Channel watercourse related to urban and golf course runoff and soil erosion during grading and construction.  |
| 2.1 | Place restrictions on the development of floodplain areas, beaches, sea cliffs, ecologically sensitive areas and potentially hazardous areas. (Coastal Act/30235, 30236, 30240, 30253)   | The Specific Plan provides for enhancement of Coastal Sage Scrub habitat in a more appropriate location where it can be maintained in perpetuity. Beach areas and sea cliffs will be preserved. No restricted development will be located within the floodplain along Salt Creek.              |
| 2.2 | Site planning and architectural design shall respond to the natural landform whenever possible to minimize grading and visual impact. (Coastal Act/30250)  | The Specific Plan provides for clustered development. The guidelines, policies, programs and development standards will ensure implementation of sensitive development. The Specific Plan has considered natural landforms to minimize grading and visual impact to surrounding neighborhoods. |

## GENERAL PLAN POLICIES

## SPECIFIC PLAN CONFORMANCE WITH GENERAL PLAN

### Conservation/Open Space (Cont.)

- |     |  |  |
|-----|--|--|
| 2.3 | Control erosion during and following construction through proper grading techniques, vegetation replanting, and the installation of proper drainage, and erosion control improvements. (Coastal Act/30243)   | The Specific Plan provides temporary landscaping of graded pads and slopes in accordance with approved City grading codes.                           |
| 2.4 | Require the practice of proper soil management techniques to reduce erosion, sedimentation, and other soil-related problems. (Coastal Act/30243)   | The Specific Plan provides temporary landscaping of graded pads and slopes in accordance with approved City grading codes.                           |
| 2.5 | Monitor beach erosion by periodically evaluating any natural changes or man-caused activities which would reduce the replenishment of sand to the beaches.   | Not applicable to the Specific Plan area.  |
| 2.6 | Consider public acquisition of significant land resources for open space when funds or opportunities are available.  | The Specific Plan provides significant public open space areas consistent with the General Plan.   |
| 2.7 | Require geotechnical studies for developments that are proposed for steep slopes (4:1 or steeper) and where geological instability may be suspected. (Coastal Act/30253)   | Preliminary geotechnical report to accompany the SDP/CDP application will fulfill this requirement.  |
| 2.8 | Discourage development in areas which have physical constraints associated with steep topography and unstable slopes; and where such areas are designated as Recreation/Open Space or include bluffs, beaches, or wetlands, exclude such areas from the calculation of net acreage available for determining development intensity or density potential. | The Specific Plan has excluded development from steep topography, recreation/open space areas, highly unstable slopes, bluffs, beaches and wetlands. |

## GENERAL PLAN POLICIES

## SPECIFIC PLAN CONFORMANCE WITH GENERAL PLAN

### Conservation/Open Space (Cont.)

- |     |   |  |
|-----|---|--|
| 2.9 | Consider preserving significant natural features where feasible as part of new development. (Coastal Act/30240/30250/30251)   | The Specific Plan has preserved significant natural features such as Salt Creek. The Resource Enhancement Program provides for the re-establishment of Coastal Sage Scrub habitat.   |
| 3.1 | Conserve important plant communities and wildlife habitats, such as marine refuge areas, riparian areas, wildlife movement corridors, wetlands, and significant tree stands through the practice of creative site planning, revegetation, and open space easement/ dedications. (Coastal Act/30240) | The Specific Plan includes a Resource Enhancement Program aimed at re-establishing Coastal Sage Scrub habitat adjacent to the Salt Creek Regional Corridor. The program will create new habitat to be used by wildlife linking the on-site Salt Creek Channel area with public open space to the north across Camino del Avion. An extensive revegetation effort is proposed utilizing on-site topsoil and plant material with a long-term maintenance and monitoring program. Existing riparian habitat within the Salt Creek Channel will be preserved and enhanced. |
| 3.2 | Require development proposals in areas expected to contain important plant and animal communities to include biological assessments.  | Biological assessments have been prepared as part of the Resource Enhancement Program and Specific Plan process.   |
| 3.3 | Encourage retention of natural vegetation and require revegetation of graded areas.   | The Specific Plan retains natural vegetation within the Salt Creek Channel. Graded pads and slopes will be revegetated in connection with development of those areas. The Resource Enhancement Program provides for the re-establishment of a fragmented Coastal Sage Scrub community.   |
| 3.4 | Restrict urban use of open space lands that have conservation or open space easements. Document those easements to ensure the staff is aware of existence.  | The Specific Plan restricts urban encroachment of open space lands. Conservation or Open Space Elements have been documented.  |
| 3.5 | Prohibit detrimental public access to the shore of the marine life refuge at the base of the Dana Point Headlands.  | This is not applicable, as the Dana Point Headlands are not within or adjacent to the Specific Plan area.  |



## GENERAL PLAN POLICIES

## SPECIFIC PLAN CONFORMANCE WITH GENERAL PLAN

### Conservation/Open Space (Cont.)

- |     |   |   |
|-----|---|---|
| 5.4 | Provide commercial areas that are conducive to pedestrian and bicycle circulation.  | The Specific Plan provides for visitor-serving recreation commercial uses that are directly accessible by an extensive trail system and resort vehicle system service.  |
| 5.5 | Actively participate in regional discussions regarding new regional airport facilities and analyze and evaluate potential impacts on the City.  | This policy is a City function.   |
| 5.6 | Encourage bicycle/trail systems to reduce air pollution.  | The Specific Plan provides for an extensive public trail system and resort vehicle service which will help reduce air pollution.  |
| 5.7 | Consider the development of shuttle systems, train or transit facilities, to help reduce vehicular trips and air pollution.   | The Specific Plan will provide for a resort vehicle system service to help reduce vehicular trips and air pollution.  |
| 6.1 | Mitigate the impacts of development on sensitive lands such as steep slopes, wetlands, cultural resources, and sensitive habitats through the development review process. (Coastal Act/30240) | The Specific Plan provides for a Resource Enhancement Program which consolidates an area of Coastal Sage Scrub habitat. Steep slopes, wetlands and cultural resources are not impacted within the Specific Plan area. |
| 6.2 | Protect and preserve the public views of the Dana Point Harbor. (Coastal Visual Resources/30251)  | This policy is not applicable as the Dana Point Harbor cannot be viewed from the Specific Plan area.  |
| 6.3 | Maintain an inventory of existing natural resources in the City through periodic updates of the City's Master Environmental Assessment.   | This policy is a City function.   |
| 6.4 | Preserve and protect the scenic and visual quality of the coastal areas as a resource of public importance. (Coastal Act/30251)   | A visual analysis has been prepared as part of this Specific Plan. The Specific Plan is designed to preserve and protect, where possible, the scenic and visual quality of the coastal area.                          |

## GENERAL PLAN POLICIES

## SPECIFIC PLAN CONFORMANCE WITH GENERAL PLAN

### Conservation/Open Space (Cont.)

- |     |  |   |
|-----|--|---|
| 6.5 | Encourage retention of permanent open space through dedication as a part of the development site plan subdivision/review process.  | The Specific Plan provides the opportunity for the dedication of all park amenities and open space areas beyond those already dedicated.  |
| 6.6 | Concentrate higher intensity uses in areas containing less sensitive landforms and preserve the most sensitive landform and natural resources as open space.   | The Specific Plan has considered the constraints of landforms and natural areas. The hotel area and residential development has been sited primarily on previously graded pads. Much of the site has been preserved as recreation open space including the Salt Creek Corridor.   |
| 6.7 | Evaluate non-developable or constrained areas for possible use as open space or recreational use. (Coastal Act/30240)  | The Specific Plan has considered constrained areas. Much of the Specific Plan area is designated as open space and recreation use. The Salt Creek Area is permanent open space.   |
| 6.8 | Preserve public access to the coastal areas through easements dedications thereby providing marine-oriented recreational uses so that transportation corridors may augment the City's open space system. (Coastal Act/30210, 30211, 30212) | The Specific Plan provides the opportunity for easement dedications to the shoreline thereby providing marine-oriented recreational uses. The golf course, beach house, community park, public open space features and trail designations established in this Specific Plan provide and protect public access and recreational opportunities to the coastal area. |
| 7.1 | Encourage the provision of a range of recreational facilities and programs to meet the needs of city residents.  | The Specific Plan provides for the dedication of land and development of Sea Terrace Community Park. A range of public recreational facilities will be provided within the park. In addition, several vista points, a promenade and extensive trails are provided within the Specific Plan area.  |
| 7.2 | Utilize utility easements as open space linkages where feasible.   | The use of utility easements to provide open space linkages was unnecessary within the Specific Plan area.  |

## GENERAL PLAN POLICIES

## SPECIFIC PLAN CONFORMANCE WITH GENERAL PLAN

### Conservation/Open Space (Cont.)

- |     |  |  |
|-----|--|--|
| 7.3 | Preserve public and private open space lands for active and passive recreational opportunities. (Coastal Act/30213)  | The Specific Plan provides for extensive recreational opportunities, including active and passive activities at Sea Terrace Community Park, several vista points and a trail system. |
| 7.4 | Encourage priority acquisition and development of parkland in neighbor-hoods deficient in park facilities.   | The Specific Plan provides opportunities for the development of Sea Terrace Community Park, vista points, a promenade and an extensive trail system.                                 |
| 7.5 | Coordinate park and open space planning with the appropriate state and county agencies.  | The Specific Plan park, open space and trails planning has been coordinated with the appropriate agencies.   |
| 7.6 | Encourage the development of parks and acquisition of open space areas to serve the needs of visitors as well as local residents.  | The Specific Plan provides both visitor and local resident recreational facilities.  |
| 8.1 | Require reasonable mitigation measures where development may affect historical, archaeological or paleontological resources. (Coastal Act/30244, 30250)  | The Specific Plan does not impact historical, archaeological or paleontological resources.   |
| 8.2 | Retain and protect significant areas of historical, archaeological, or paleontological value for education and scientific purposes. (Coastal Act/30244, 30250)   | The Specific Plan does not impact historical, archaeological or paleontological resources.   |
| 8.3 | Development adjacent to a place, structure or object found to be of historic significance should be designed so that the uses permitted and the architectural design will protect the visual setting of the historical site. (Coastal Act/30250) | The Specific Plan does not propose development adjacent to historic resources.   |

**GENERAL PLAN POLICIES**

**SPECIFIC PLAN CONFORMANCE  
WITH GENERAL PLAN**

Conservation/Open Space (Cont.)

8.4 Develop and maintain a cultural resource inventory.

This policy is a City function.

Public Facilities/Growth Management Element

1.1 Work closely with local-serving water and sewer districts in determining future area needs and expanding sewer service to the Headlands area, when necessary. (Coastal Act/30250, 30255, 30254)

This policy does not apply to the Specific Plan.

1.2 Encourage the use of drought resistant landscaping to reduce overall water use.

The Specific Plan encourages the use of drought resistant landscaping to reduce overall water use through the landscape guidelines and Resource Enhancement Program.

1.3 Support public education programs for water conservation.

This policy is of City-wide application.

1.4 Support the appropriate regional agencies in developing and utilizing reclaimed water facilities.

The Specific Plan supports the appropriate regional agencies in developing and utilizing reclaimed water facilities through the expansion of the use of reclaimed water for the resort.

1.5 Consider requiring new development to pay for the cost of extending reclaimed water lines in the City.

The Specific Plan provides for extending the reclaimed water lines for the Specific Plan area.

1.6 Support the efforts of water and sewer agencies to encourage recycling of wastes and proper disposal of household wastes and waste oil.

This policy is of citywide application.

GENERAL PLAN POLICIES

SPECIFIC PLAN CONFORMANCE  
WITH GENERAL PLAN

Public Facilities/Growth Management  
(Cont.)

- |     |   |  |
|-----|---|--|
| 1.7 | Evaluate the varying levels of service provided by the water and sewer districts serving the City and support increased coordination among these districts in order to provide consistent service levels.     | This policy is a City function.          |
| 1.8 | Encourage and support water and sewer districts in the effective management of their revenue resources to ensure equitable service throughout the City.   | This policy is a City function.          |
| 2.1 | Identify local storm drainage deficiencies and develop a capital improvements program for the correction and replacement of aging or inadequate drainage system components. (Coastal Act/30235, 30236, 30253) | This policy is a City function.          |
| 2.2 | Work with the Orange County Flood Control District in ensuring the adequacy of regional storm drainage facilities. (Coastal Act/30235, 30236, 30253)  | This policy is a City function.          |
| 3.1 | Continue to work with the cities of San Clemente and San Juan Capistrano in the development of an SRR Element which will include a recycling plan.  | This policy is a City function.          |
| 3.2 | Identify and evaluate alternatives to reduce solid waste in accordance with AB 939.   | This policy is of City-wide application. |
| 3.3 | Support litter clean up efforts on public and private properties.   | This policy is of City-wide application. |

**GENERAL PLAN POLICIES**

**SPECIFIC PLAN CONFORMANCE  
WITH GENERAL PLAN**

**Public Facilities/Growth Management  
(Cont.)**

- |     |  |   |
|-----|--|---|
| 5.2 | Assess the City's needs for a governmental/civic center and identify suitable sites.   | This policy is not applicable as it is a City initiative.   |
| 5.3 | Develop a capital improvements plan to include service standards and a mitigation fee program for new development.   | This policy is not applicable as it is a City initiative.   |
| 5.4 | Consider the need for multipurpose meeting rooms and space for community events.   | This policy is not applicable as it is a City initiative.   |
| 5.5 | Consider the need for a local historical museum (Coastal Act/30213)  | This policy is not applicable as it is a City initiative.   |
| 5.6 | Assess the cultural facilities needs for the City, including the need to expand existing facilities.   | This policy is not applicable as it is a City initiative.   |
| 5.7 | Encourage well-planned neighborhood and community park facilities that are within convenient access to all residential areas.  | The Specific Plan provides for comprehensively planned high quality residential neighborhoods and community park facilities that are within convenient access to all residential areas. |
| 5.8 | Coordinate the approval of new development with the capacity of the Capistrano Unified School District.  | The Specific Plan provides for coordinating the approval of its development with the capacity of the Capistrano Unified School District.  |
| 5.9 | Ensure to the extent feasible that adequate sites are available for public facilities, churches, schools, museum(s), government offices, a civic/cultural center or other facilities that may serve the public interest. | This policy is not applicable to the Specific Plan as it is a City policy. The Specific Plan encourages and supports this policy.<br><br>See comment 29                                 |

## GENERAL PLAN POLICIES

## SPECIFIC PLAN CONFORMANCE WITH GENERAL PLAN

### Public Facilities/Growth Management (Cont.)

- |      |  |  |
|------|--|--|
| 5.10 | Develop a program for public art.  | The Specific Plan requires that public art shall be provided and shall be approved as part of the site development permit process. |
| 5.11 | Consider creating various funding mechanisms, such as developer impact fees, to contribute toward the cost of new civic facilities.  | This policy is not applicable as it is a City initiative.  |
| 5.12 | Coordinate the provision of community facilities with the development of new parks and recreational facilities.  | The Specific Plan provides for the development of new community facilities in conjunction with the completion of Sea Terrace Park. |
| 6.1  | Where feasible, provide underground utility lines in all neighborhoods and continue to underground utility lines in future developments.   | The Specific Plan provides underground utility lines in all neighborhoods.   |
| 6.2  | Promote the enhancement of governmental process information through cable television access.   | This policy is not applicable as it is a City initiative.  |
| 6.3  | Encourage the use of solar energy to supplement conventional heating systems.  | This policy is of City-wide application.   |
| 7.1  | Adopt Orange County level of service standards for law enforcement, fire, library, and storm drains, and Capistrano Bay Parks and Recreation District standards for parks and open space (see Table PF-1). | This policy is not applicable as it is a City initiative.  |

GENERAL PLAN POLICIES

SPECIFIC PLAN CONFORMANCE  
WITH GENERAL PLAN

Public Facilities/Growth Management  
(Cont.)

- |     |   |  |
|-----|---|--|
| 7.2 | Within three years of the issuance of the first building permit for a development project or within five years of the first grading permit for said development project, whichever occurs first, the necessary improvements to transportation facilities to which the project contributes measurable traffic must be constructed and completed to attain Level of Service (LOS) "C" at the intersections on primary arterials, secondary arterials and local streets, and LOS "D" at intersections on major arterials and State highways under the sole control of the City/County. | This is a City-wide policy. To the extent that necessary roadway improvements within the Specific Plan area are a part of such mitigation.                 |
| 7.3 | Develop a program to monitor new development to ensure compliance with adopted level of service standards.  | This policy is not applicable as it is a City initiative.  |
| 7.4 | Require that all development projects participate in comprehensive public facility financing plans on a pro-rata basis as a condition of development approval, except where an increased level of participation exceeding these requirements is established through negotiated legal mechanisms.  | The Specific Plan provides for fair-share contribution to public facility financing plans through improvements to be made in conjunction with development. |
| 7.5 | Require all new development to pay its share of the costs of mitigating its traffic impacts, including regional impacts. Work with other jurisdictions to determine minimally acceptable impact fee levels.   | The Specific Plan provides for its provision of the traffic impacts.   |



## GENERAL PLAN POLICIES

## SPECIFIC PLAN CONFORMANCE WITH GENERAL PLAN

### Public Facilities/Growth Management (Cont.)

- |      |   |   |
|------|---|---|
| 7.6  | Require that all development be phased in accordance with a Comprehensive Phasing Program (CPP). The CPP shall include development phasing plans which establish phasing allocation commensurate with roadway and public facility capacities and an overall buildout development plan which can be supported by the implementation of the planned infrastructure. | The Specific Plan provides for a comprehensive phasing program consistent with the general area specific of the policies.               |
| 7.7  | Develop a Capital Improvement Program to meet and maintain adopted level of service standards for traffic and public services.  | This policy is not applicable as it is a City initiative.   |
| 7.8  | Promote traffic reduction strategies through TDM measures.  | The Specific Plan promotes traffic reduction strategies through TDM measures.   |
| 7.9  | Require development of large properties to include a master plan and an environmental analysis of the proposed development. (Coastal Act/30250)   | The Specific Plan is the master plan for the proposed development. A Mitigated Negative Declaration has been prepared pursuant to CEQA. |
| 7.10 | Ensure that growth management policies are consistent with the policies of the General Plan.  | This policy is not applicable as it is a City initiative.   |
| 7.11 | Require development of large properties to prepare a comprehensive development plan and environmental analysis to evaluate the impacts of the proposed project.   | The Specific Plan is the master plan for the proposed development. A Mitigated Negative Declaration has been prepared pursuant to CEQA. |

**GENERAL PLAN POLICIES**

**SPECIFIC PLAN CONFORMANCE  
WITH GENERAL PLAN**

**Economic Developments (Cont.)**

- |     |  |  |
|-----|--|--|
| 3.4 | Continue with existing plans for redevelopment within areas of the community where revitalization is warranted.                                      | The Specific Plan area does not contain any redevelopment areas.   |
| 3.5 | Promote conference and visitor activities to ensure the long term viability of this major revenue generator. (Coastal Act/30213)                     | The Specific Plan provides for conference and visitor activities through the resort hotel and recreational facilities. <b>See comment 30</b>                           |
| 4.1 | Promote development of retail uses which serve local needs and diversify the selection of conveniently located goods and services.                   | The General Plan does not provide for retail uses within the Specific Plan area, which is adjacent to a major retail center.   |
| 4.2 | Promote visitor serving retail uses to serve the growing demand for harbor, beach and coastal facilities, especially day use visitors. (Coastal Act) | The Specific Plan provides visitor serving retail uses to serve growing demand, through the hotel beach house, and golf course facilities.                             |
| 4.3 | Promote the overlap between visitor and resident serving retail uses by encouraging retail goods and services which serve both market segments.      | The General Plan does not provide for general retail uses within the Specific Plan area, which is adjacent to a major commercial center.                               |
| 5.1 | Encourage the early development of resort properties at the Headlands site. (Coastal Act/30213, 30250)   | The policy is not applicable, as the Headlands is not within or adjacent to the Specific Plan area.  |
| 5.2 | Encourage the early development of resort properties at the Monarch Beach site. (Coastal Act/30213, 30234)   | The Specific Plan expressly encourages the early development of resort properties at the Monarch Beach site.   |
| 5.3 | Encourage a balanced mix of visitor serving uses to complement the marine environment and commercial activities.                                     | This policy is not applicable, as the Specific Plan area has no development sites that are contiguous with or impact the marine environment and commercial activities. |
| 5.4 | Discourage the development of timeshares.  | The Specific Plan does not provide for timeshares.   |
| 6.1 | Encourage a balance in the development of commercial uses.   | This policy is not applicable, as the General Plan does not provide for commercial uses within the Specific Plan area.   |



**SCOPING REQUEST FOR ANALYSIS AND ACTION**  
**Robert and Deanna Saint-Aubin**

**WE RESPECTFULLY REQUEST** that LSA, in preparing its Draft EIR:

- ✓ Analyze the proposed project under the check list contained in the Initial Study considering each item to be a potentially serious impact.
- ✓ Propose mitigation, if possible, for each item; mitigation to the north, south and west, but not to the east, is not mitigation.
- ✓ Review and analyze all of the comments we previously submitted with respect to the discredited MND.
- ✓ Assure that the project is in compliance with each and every line of all of the Dana Point Plan Elements.
- ✓ Assure that the project is in compliance with each and every line of the Monarch Beach Resort Specific Plan.
- ✓ Assure that the project is fully and completely in compliance with the Dana Point Design Guidelines.
- ✓ Analyze the project with respect to every issue raised at the March 4, 2010, "Scoping Session."
- ✓ Verify by title review and survey that in fact the western edge of the property is the current eastern edge of the Crown Valley sidewalk.
- ✓ Verify by survey that the developer owns the quantity of unencumbered land claimed.
- ✓ Determine whether or not the ranch/orchard disposed of chlorinated or other pesticides and if they are still present on the site and in the material to be excavated.
- ✓ Determine how much dirt will be excavated and when and where it will be stored, placed and hauled if hauled off site.
- ✓ Install accurate story poles showing property lines, excavation lines, retaining walls (including their bases), structures and buildings.
- ✓ Determine whether the zoning of the site was ever properly changed from residential, including providing all notices, hearings and actions with respect to the specific property.
- ✓ If still operating under an historic variance, assure that the project is fully in compliance with the historic zoning.
- ✓ Determine how the site, currently, during construction, and after completion, will comply with storm water runoff and drainage requirements.
- ✓ Analyze the 100-foot deep excavation into the bluff mentioned in the Scoping Session documents and determine total quantities of materials removed and the life cycle of such materials, accounting for all that will migrate offsite.
- ✓ Analyze the aesthetic impact of the bluff destruction, excavation, stockpiling and backfilling operations on the entire Salt Creek Basin, including all of the conservation elements, the Salt Creek Trail, the Salt Creek Scenic Corridor, the golf course, and the neighbors, as well as the coastal sage scrub and gnat catcher refuge.
- ✓ The project time line presented at the Scoping Session shows large gaps. For what

## **SCOPING REQUEST FOR ANALYSIS AND ACTION**

### **Robert and Deanna Saint-Aubin**

- purpose? Will the site be finished or in a construction zone status for the duration of the gaps? Will the staging areas be removed during the construction hiatus?
- ✓ Determine the impact of the project on Salt Creek, on the Salt Creek Treatment Plant and on Salt Creek Beach.
  - ✓ Determine the impact of the project on the gnatcatcher and Coastal Sage Scrub.
  - ✓ Analyze the noise and dust pollution from the site and the construction and the resulting project.
  - ✓ Analyze the parking.
  - ✓ Analyze the construction and completion circulation.
  - ✓ Analyze the impact of the project on the Strand Parking and beach access.
  - ✓ Analyze the financing of the project – how much money do they now have and how will the developer raise the funding required to complete the parking garage? Note the shaky funding of Pastor Rick Warren and of the Crystal Cathedral, which is abandoning a similar established facility in San Juan Capistrano. Dana Point does not need another half-complete, abandoned project.
  - ✓ Analyze the alternative of moving the new buildings back from the bluff to over the parking garage at Crown Valley. Note that there is no ocean view from Crown Valley except between the sanctuary and the Monarch Bay Villas. Therefore, two-story structures could be erected above the parking garage along Crown Valley on the northern two-thirds of the property.
  - ✓ Analyze the alternative of purchasing off-site facilities, such as the Greenfield Expo Center, the abandoned Crystal Cathedral project in San Juan Capistrano, the abandoned auto dealer sites on Camino Capistrano, or SCWD Capistrano/Stonehill available land.
  - ✓ Make a site visit to 53 Cassis, Corniche Sur Mer, Ritz Pointe. Call 949-496-5025.
  - ✓ Analyze the landslide, geophysical and geotechnical characteristics of the site and all of the studies conducted since the establishment of the church on the site.
  - ✓ Determine the exact purpose of each proposed building.
  - ✓ Determine when the church expects to expand the school facilities to K through 8<sup>th</sup> Grade.
  - ✓ Assure that the South Coast Water District will make available sufficient water supplies to totally suppress all dust beyond the church property line.

Attached is an excerpt from the discredited MND  
that clearly states the developers intention  
to remove 101,359 cubic yards of material,  
most of which will be stored on the edge of  
the Salt Creek Corridor

standard or contribution to an existing or projected air quality violation. The following is a summary of the short-term and long-term air quality impacts evaluated in the Air Quality Assessment and the results of the analysis.

### Short-Term Air Quality Impacts

Short-term impacts are usually the result of construction or grading operations. The "1993 CEQA Air Quality Handbook" by the SCAQMD has established significance thresholds to assess the regional impact of project related air pollutant emissions. Table 3-1 presents these significance thresholds. A project with daily emission rates below these thresholds are considered to have a less than significant effect on regional air quality throughout the South Coast Air Basin.

**Table 3-1 - SCAQMD Regional Pollutant Emission Thresholds of Significance**

	Pollutant Emissions (lbs/day)				
	CO	SO <sub>x</sub>	ROG	NO <sub>x</sub>	PM <sub>10</sub>
Construction	550	150	75	100	150
Operation	550	150	55	55	150

Temporary impacts will result from the project's construction activities. Air pollutants will be emitted by construction equipment and fugitive dust will be generated during grading and site preparation. As mentioned previously, per the CEQA Handbook, emission factor for disturbed soil is 0.40 tons of PM<sub>10</sub> per month per acre. If water or other soil stabilizers are used to control dust as required by SCAQMD Rule 403, the emissions can be reduced by 50%.

✓ The proposed project will require grading (cut/fill of earth material). The excavation of the area will consist of a total of approximately 101,359 cubic yards of cut-and-fill (total of all stockpile stages) and occur in five stages. Each stage involves the removal, backfill, and compaction of earth material. Excavation period per stage is anticipated to be between 18 and 22 days for removal, and between 22 and 30 days for backfill and compaction. The total time of excavation is projected to occur between four to five months. The construction equipment involved would include 1 bull dozer, 1 CAT 345 excavator, 2 CAT 637 twin engine scrapers, and a water truck. The following analyses were based on this information. Typical emission rates for construction equipment were obtained from the SCAQMD Air Quality Handbook.

### Localized Significant Thresholds (LSTs)

The SCAQMD developed localized significance threshold (LST) methodology and mass rate look-up tables by source receptor area (SRA) that can be used to determine whether or not a project may generate significant adverse localized air quality impacts. LSTs represent the maximum emissions from a project that will not cause or contribute to an exceedance of the most stringent applicable federal or state ambient air quality standard, and are developed based on the ambient concentrations of that pollutant for each source receptor area. The LST mass rate look-up tables provided by the SCAQMD allow one to determine if the daily emissions for proposed construction or operational

Attached is shown the present ocean view  
from the property

And the proposed location of the  
Administration Building, which will  
obliterate it



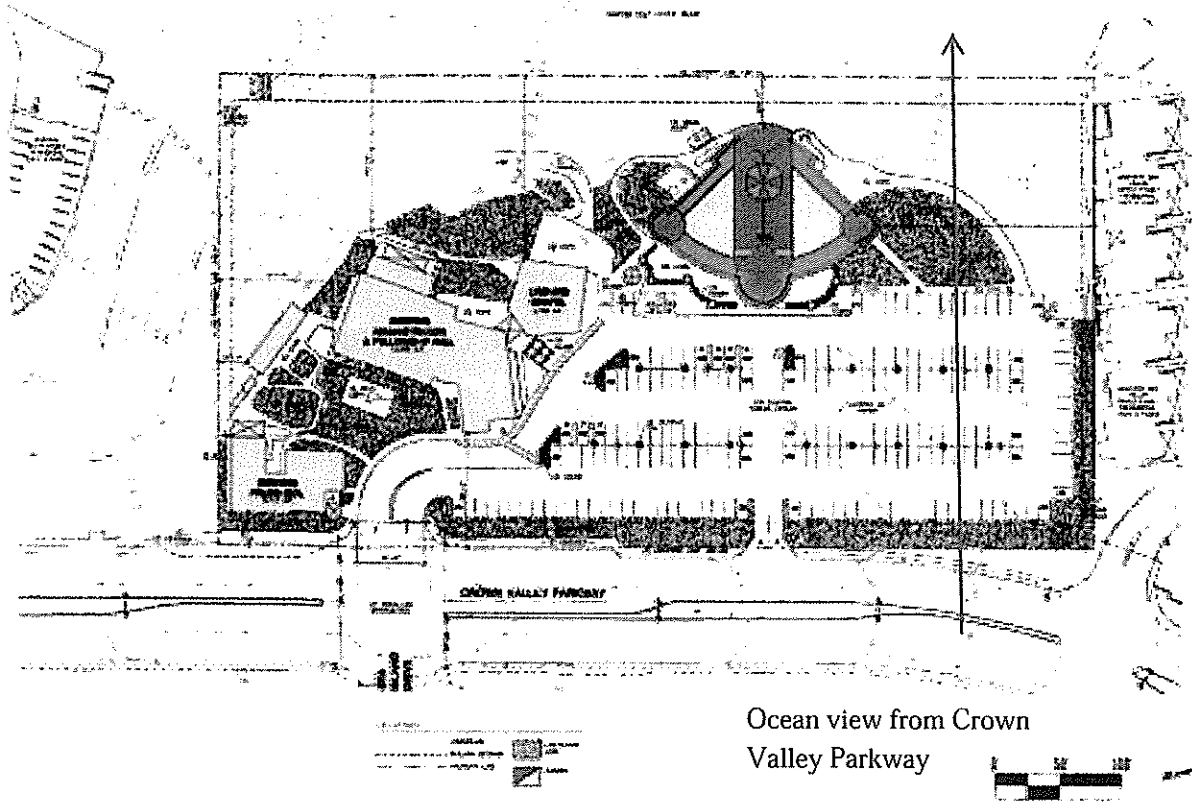

Ocean view from Crown Valley Parkway



Mestre Greve Associates

**Exhibit 2  
Existing Site Plan**

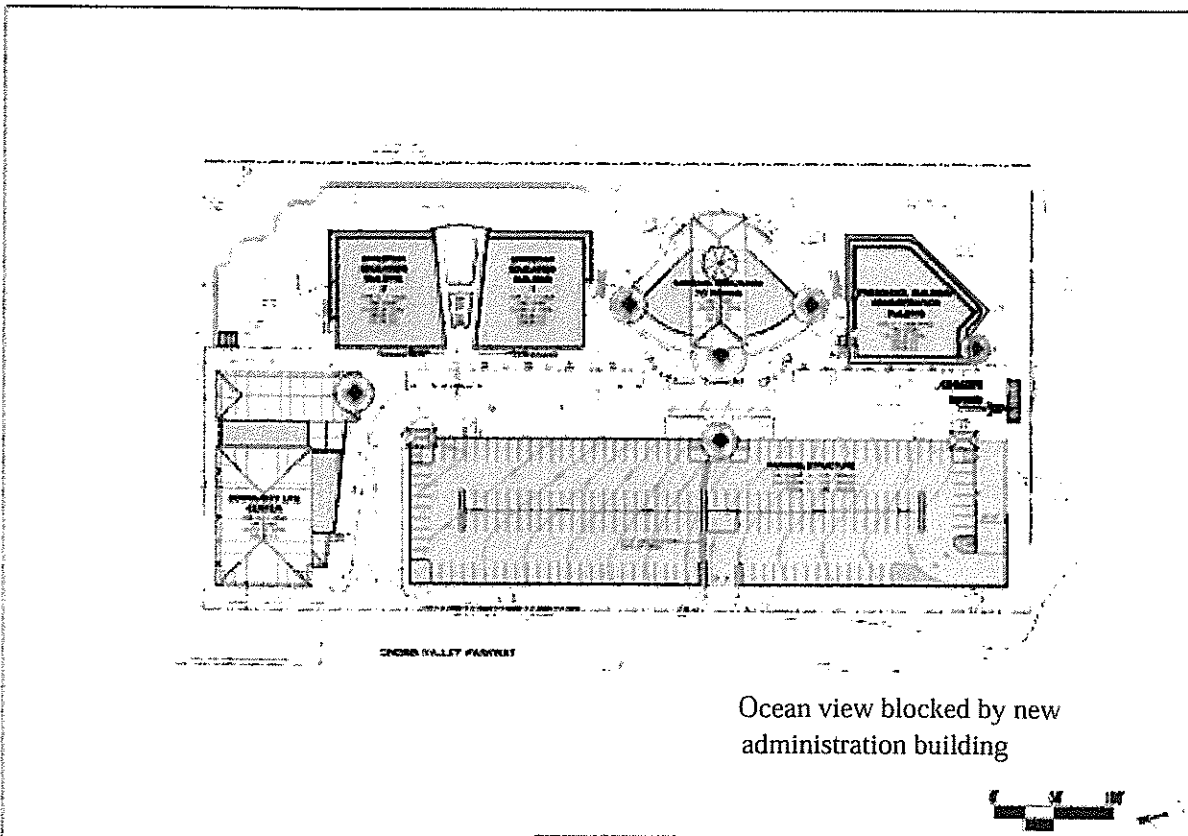

Ocean view blocked by new administration building



Mestre Greve Associates

**Exhibit 3  
Proposed Site Plan**

Attached is shown an alternative building plan.

It can be accomplished by moving  
the Parking Garage to the northwest corner above ground  
and constructing the Community Life Center,  
Buildings 1 and 2 and the Administration Building  
on top of the Garage.

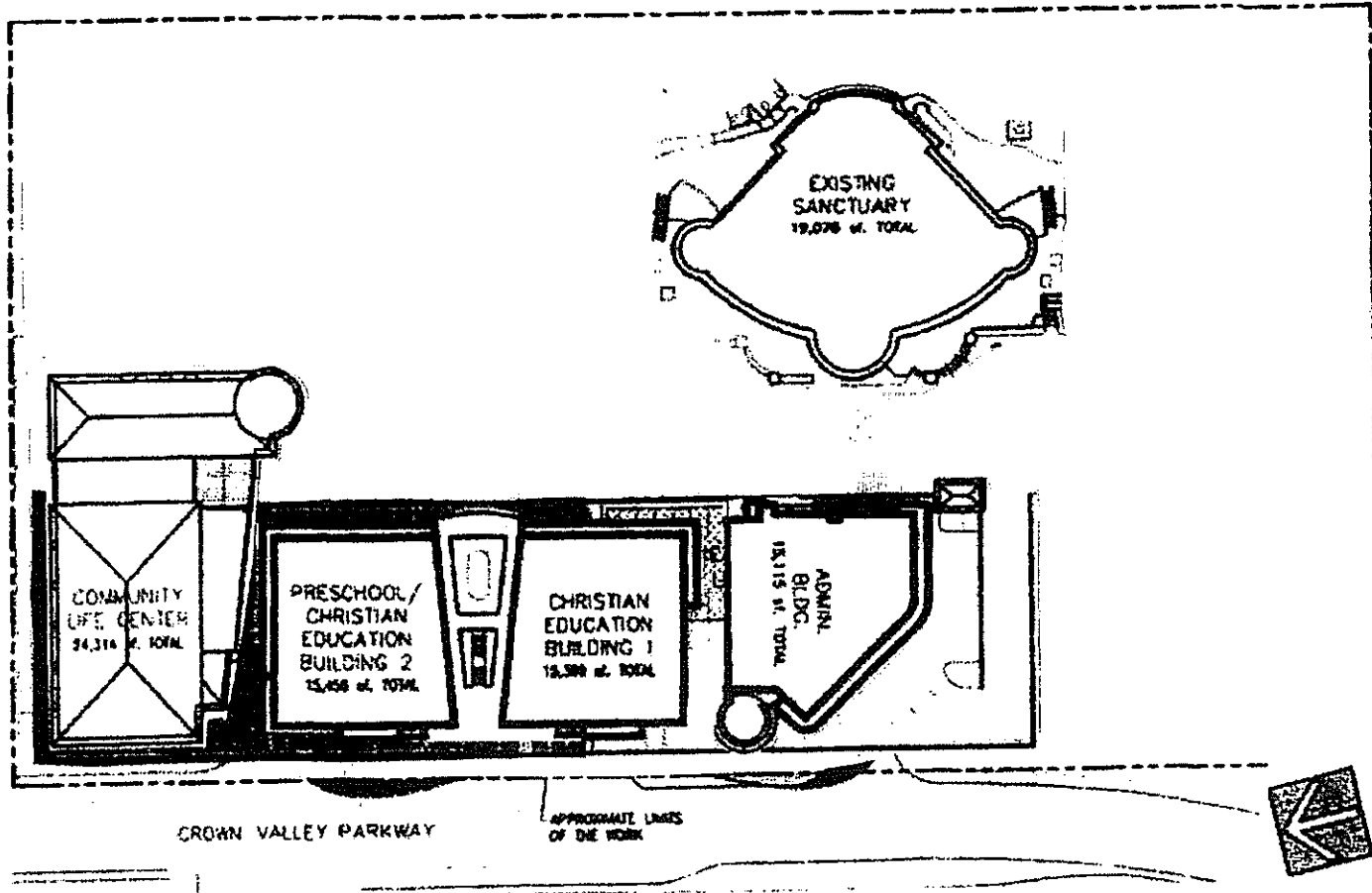

COMMUNITY LIFE CENTER  
24,314 sq. TOTAL

PRESCHOOL/  
CHRISTIAN  
EDUCATION  
BUILDING 2  
15,468 sq. TOTAL

CHRISTIAN  
EDUCATION  
BUILDING 1  
18,399 sq. TOTAL

ADMIN.  
BLDG.  
18,115 sq. TOTAL

EXISTING  
SANCTUARY  
19,076 sq. TOTAL

CROWN VALLEY PARKWAY

APPROXIMATE LINES  
OF THE WORK

Attached is the  
Modified IS Checklist showing  
Items of potentially significant impact

Comment: Throughout this Initial Study checklist, which improperly recycles the discredited and rejected MND without the benefit of new lipstick, we have added red check marks for all of the items for which a finding of material adverse impact must be made. The entire project must be reexamined, with new untainted independent studies by independent neutral professionals.

## Appendix A - Environmental Checklist Form

### Introduction

This Initial Study has been prepared pursuant to the California Environmental Quality Act (CEQA) and the CEQA Guidelines as amended to determine if the proposed South Shores Church Master Plan in the City of Dana Point will have the potential to cause significant effects on the environment. The City of Dana Point will use the Initial Study in deciding whether to approve the project and whether to prepare an Environmental Impact Report (EIR), approve a Negative Declaration (ND), or approve a Mitigated Negative Declaration (MND) with mitigation measures.

---

### Project Background

- a) Project Title:  
South Shores Church Master Plan
- b) Lead Agency Name and Address:  
City of Dana Point  
Community Development Department  
33282 Golden Lantern  
Dana Point, CA 92629
- c) Contact Person and Phone Number:  
Saima Qureshy, AICP, Senior Planner  
Community Development Department  
(949) 248-3568
- d) Project Location:  
The project is located at 32712 Crown Valley Parkway in Dana Point, Orange County, California and surrounds the main sanctuary on the church campus.
- e) Project Sponsor's Name and Address:  
South Shores Church  
32712 Crown Valley Parkway  
Dana Point, CA 92629
- f) General Plan Designation:  
Community Facilities

g) Zoning:

Community Facilities

h) Description of Project: (Describe the whole action involved, including but not limited to later phases of the project, and any secondary, support, or off-site features necessary for its implementation. Attach additional sheets if necessary.)

The project is a proposed addition to an existing church, including a new Community Life Center (Fellowship hall/gymnasium), replacement and construction of a new Administration Building, Christian Education Buildings, and a two-level (one level is subterranean) parking structure. The detailed project description and project plans were previously presented in Section 2 of this environmental document.

The proposed Administration Building (also to be used for Preschool until the Christian Education buildings are completed) is a two-story structure totaling 15,115 square feet in size. The height of this building is approximately 31 feet. This building is proposed to be located adjacent to the existing church sanctuary on the southeast portion of the site. The building is located near the Monarch Bay Villas, which are residential condominiums. The proposed building has a setback of 41'-9" from the Monarch Bay Villas property line. The two (2) proposed Christian Education buildings (two-stories each, 15,456 square feet and 15,399 square feet in size) are proposed to be located adjacent to the existing church sanctuary on the northeast area of the property. These buildings are approximately 31' in height facing towards the back of the property and to the north (adjacent to the Monarch Apartments). The height of the building closest to the sanctuary is approximately 17'-6". The proposed Community Life Center (Fellowship Hall/gymnasium) building is approximately 24,314 square feet in size located on the northwesterly area of the site and at the intersection of Crown Valley Parkway and Sea Island Drive. This two-story building is approximately 35' in height. The proposed two-level parking structure (deck) and surface parking will provide a total of 421 spaces. Currently the SSC has 228 surface parking stalls. Although the parking structure is two-levels, one level will be below grade.

i) Surrounding Land Uses and Setting:

Surrounding and nearby land uses to the project site include residential uses, resort properties, a golf course and local roadways.

j) Other public agencies whose approval is required (e.g., permits, financing approval, or participation agreement.)

Orange County Fire Authority, San Diego Regional Water Quality Control Board, utility and service providers

g) Zoning:

Community Facilities

h) Description of Project: (Describe the whole action involved, including but not limited to later phases of the project, and any secondary, support, or off-site features necessary for its implementation. Attach additional sheets if necessary.)

The project is a proposed addition to an existing church, including a new Community Life Center (Fellowship hall/gymnasium), replacement and construction of a new Administration Building, Christian Education Buildings, and a two-level (one level is subterranean) parking structure. The detailed project description and project plans were previously presented in Section 2 of this environmental document.

The proposed Administration Building (also to be used for Preschool until the ~~Christian Education buildings are completed~~) is a two-story structure totaling 15,115 square feet in size. The height of this building is approximately 31 feet. This building is proposed to be located adjacent to the existing church sanctuary on the southeast portion of the site. The building is located near the Monarch Bay Villas, which are residential condominiums. The proposed building has a setback of 41'-9" from the Monarch Bay Villas property line. The two (2) proposed Christian Education buildings (two-stories each, 15,456 square feet and 15,399 square feet in size) are proposed to be located adjacent to the existing church sanctuary on the northeast area of the property. These buildings are approximately 31' in height facing towards the back of the property and to the north (adjacent to the Monarch Apartments). The height of the building closest to the sanctuary is approximately 17'-6". The proposed Community Life Center (Fellowship Hall/gymnasium) building is approximately 24,314 square feet in size located on the northwesterly area of the site and at the intersection of Crown Valley Parkway and Sea Island Drive. This two-story building is approximately 35' in height. The proposed two-level parking structure (deck) and surface parking will provide a total of 421 spaces. Currently the SSC has 228 surface parking stalls. Although the parking structure is two-levels, one level will be below grade.

i) Surrounding Land Uses and Setting:

Surrounding and nearby land uses to the project site include residential uses, resort properties, a golf course and local roadways.

j) Other public agencies whose approval is required (e.g., permits, financing approval, or participation agreement.)

Orange County Fire Authority, San Diego Regional Water Quality Control Board, utility and service providers

**Environmental Factors Potentially Affected:**

The environmental factors checked below would be potentially affected by this project, involving at least one impact that is a "Potentially Significant Impact" as indicated by the checklist on the following pages.

Aesthetics

Hydrology & Water  
Quality

Utilities & Service  
Systems

Agriculture Resources

Land Use Planning

Transportation/  
Circulation

Air Quality

Mineral Resources

Biological Resources

Noise

Mandatory Findings of  
Significance

Cultural Resources

Population & Housing

Geology & Soils

Public Services

Hazards & Hazardous  
Materials

Recreation



**Determination (To be completed by the Lead Agency)**

On the basis of this initial evaluation:

I find that the proposed project COULD NOT have a significant effect on the environment, and a NEGATIVE DECLARATION will be prepared.	<input type="checkbox"/>
I find that although the proposed project could have a significant effect on the environment, there will not be a significant effect in this case because revisions in the project have been made by or agreed to by the project proponent. A MITIGATED NEGATIVE DECLARATION will be prepared.	<input checked="" type="checkbox"/>
I find that the proposed project MAY have a significant effect on the environment, and ENVIRONMENTAL IMPACT REPORT is required.	<input checked="" type="checkbox"/>
I find that the proposed project MAY have a significant effect(s) on the environment, but at least one effect 1) has been adequately analyzed in an earlier document pursuant to applicable legal standards, and 2) has been addressed by mitigation measures based on the earlier analysis as described on attached sheets, if the effect is a "potentially significant impact" or "potentially significant unless mitigated." An ENVIRONMENTAL IMPACT REPORT is required, but it must analyze only the effects that remain to be addressed.	<input type="checkbox"/>
I find that although the proposed project could have a significant effect on the environment, there WILL NOT be a significant effect in this case because all potentially significant effects (a) have been analyzed adequately in an earlier EIR or NEGATIVE DECLARATION pursuant to applicable standards and (b) have been avoided or mitigated pursuant to that earlier EIR, including revisions or mitigation measures that are imposed upon the proposed project, nothing further is required.	<input type="checkbox"/>

Submitted by: City of Dana Point  
Community Development Department

Prepared by: Hodge & Associates

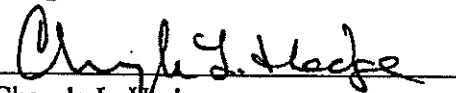
  
Cheryle L. Hodge  
Hodge & Associates

4/24/09  
date

COMMENT: Note that although presented as an independent third-party consultant, at the time of preparation of the original of this document, Cheryle L. Hodge was an undisclosed Baptist Church parishioner and deputy chairman of the building committee proposing to develop this project.

## Evaluation of Environmental Impacts

1. A brief explanation is required for all answers except "No Impact" answers that are adequately supported by the information sources show that the impact simply does not apply to projects like the one involved (e.g., the project falls outside a fault rupture zone). A "No Impact" answer should be explained where it is based on project-specific factors as well as general standards (e.g., the project will not expose sensitive receptors to pollutants, based on a project screening analysis).
2. All answers must take account the whole action involved, including off-site as well as on-site, cumulative as well as project-level, indirect as well as direct, and construction as well as operational impacts.
3. Once the lead agency has determined that a particular physical impact may occur, then the checklist answers must indicate whether the impact is potentially significant, less than significant with mitigation, or less than significant. "Potentially Significant Impact" is appropriate if there is substantial evidence that an effect may be significant. If there are one or more "Potentially Significant Impact" entries when the determination is made, an EIR is required.
4. "Negative Declaration: Less Than Significant With Mitigation Incorporated" applies where the incorporation of mitigation measures has reduced an effect from "Potentially Significant Impact" to a "Less Than Significant Impact." The lead agency must describe the mitigation measures, and briefly explain how they reduce the effect to a less than significant level (mitigation measures from Section XVII, "Earlier Analyses," may be cross-referenced).
5. Earlier analyses may be used where, pursuant to the tiering, program EIR, or other CEQA process, an effect has been adequately analyzed in an earlier EIR or negative declaration, Section 15063 (c)(3)(D). In this case, a brief discussion should identify the following:
  - a. Earlier Analysis Used. Identify and state where they are available for review.
  - b. Impacts Adequately Addressed. Identify which effects from the checklist were within the scope of and adequately analyzed in an earlier document pursuant to applicable legal standards, and state whether such effects were addressed by mitigation measures based on earlier analysis.
  - c. Mitigation Measures. For effects that are "Less Than Significant With Mitigation Incorporated," describes the mitigation measures which were incorporated or refined from the earlier document and the extent to which they address site-specific conditions for the project.
6. Lead agencies are encouraged to incorporate into the checklist references to information sources for potential impacts (e.g., general plans, zoning ordinances). References to previously prepared or outside documents should, where appropriate, include a reference to the page or pages where the statement is substantiated.
7. Supporting Information Sources: A source list should be attached, and other sources used or individuals contacted should be cited in the discussion.
8. This is only a suggested form, and the lead agencies are free to use different formats; however, lead agency should normally address the questions from the checklist that are relevant to a project's environmental effects in whatever format is selected.
9. The explanation of each issue should identify:
  - a. the significance criteria or threshold, if any, used to evaluate each question; and
  - b. the mitigation measure identified, if any, to reduce the impact to less than significance.

**City of Dana Point  
Environmental Checklist**

	Potentially Significant Impact	Less Than Significant With Mitigation Incorporated	Less than Significant Impact	No Impact
<b>I. AESTHETICS</b>				
Would the project:				
a) Have a substantial adverse effect on a scenic vista?	<input checked="" type="checkbox"/>	<input type="checkbox"/>	<input checked="" type="checkbox"/>	<input type="checkbox"/>
b) Substantially damage scenic resources, including, but not limited to, trees, rock outcroppings, and historic buildings within a state scenic highway?	<input checked="" type="checkbox"/>	<input type="checkbox"/>	<input checked="" type="checkbox"/>	<input type="checkbox"/>
c) Substantially degrade the existing visual character or quality of the site and its surroundings?	<input checked="" type="checkbox"/>	<input type="checkbox"/>	<input checked="" type="checkbox"/>	<input type="checkbox"/>
d) Create a new source of substantial light or glare which would adversely affect day or nighttime views in the area?	<input checked="" type="checkbox"/>	<input type="checkbox"/>	<input checked="" type="checkbox"/>	<input type="checkbox"/>
<b>II. AGRICULTURE RESOURCES</b>				
Would the project:				
a) Convert Prime Farmland, Unique Farmland, or Farmland of Statewide Importance (Farmland), as shown on the maps prepared pursuant to the Farmland Mapping and Monitoring Program of the California Resources Agency, to non-agricultural use?	<input type="checkbox"/>	<input type="checkbox"/>	<input type="checkbox"/>	<input checked="" type="checkbox"/>
b) Conflict with existing zoning for agricultural use, or a Williamson Act contract?	<input type="checkbox"/>	<input type="checkbox"/>	<input type="checkbox"/>	<input checked="" type="checkbox"/>
c) Involve other changes in the existing environment which, due to their location or nature, could result in conversion of Farmland, to non-agricultural use?	<input type="checkbox"/>	<input type="checkbox"/>	<input type="checkbox"/>	<input checked="" type="checkbox"/>
<b>III. AIR QUALITY</b>				
Would the project:				
a) Conflict with or obstruct implementation of the applicable air quality plan?	<input checked="" type="checkbox"/>	<input type="checkbox"/>	<input type="checkbox"/>	<input checked="" type="checkbox"/>
b) Violate any air quality standard or contribute to an existing or projected air quality violation?	<input checked="" type="checkbox"/>	<input checked="" type="checkbox"/>	<input type="checkbox"/>	<input type="checkbox"/>
c) Result in a cumulatively considerable net increase of any criteria pollutant for which the project region is non-attainment under an applicable federal or state ambient air quality standard (including releasing emissions which exceed quantitative thresholds for ozone precursors)?	<input checked="" type="checkbox"/>	<input type="checkbox"/>	<input checked="" type="checkbox"/>	<input type="checkbox"/>
d) Expose sensitive receptors to substantial pollutant concentrations?	<input checked="" type="checkbox"/>	<input type="checkbox"/>	<input checked="" type="checkbox"/>	<input type="checkbox"/>
e) Create objectionable odors affecting a substantial number of people?	<input checked="" type="checkbox"/>	<input type="checkbox"/>	<input type="checkbox"/>	<input checked="" type="checkbox"/>

Appendix A -  
Environmental Checklist Form

	Potentially Significant Impact	Less Than Significant With Mitigation Incorporated	Less than Significant Impact	No Impact
<b>IV. BIOLOGICAL RESOURCES</b>				
Would the project:				
a) Have a substantial adverse effect, either directly or through habitat modifications, on any species identified as a candidate, sensitive, or special status species in local or regional plans, policies, or regulations or by the California Department of Fish and Game or U.S. Fish and Wildlife Service?	<input checked="" type="checkbox"/>	<input checked="" type="checkbox"/>	<input type="checkbox"/>	<input type="checkbox"/>
b) Have a substantial adverse effect on any riparian habitat or other sensitive natural community identified in local or regional plans, policies, regulations or by the California Department of Fish and Game or U.S. Fish and Wildlife Service?	<input checked="" type="checkbox"/>	<input type="checkbox"/>	<input type="checkbox"/>	<input checked="" type="checkbox"/>
c) Have a substantial adverse effect on federally protected wetlands as defined by Section 404 of the Clean Water Act (including, but not limited to, marsh, vernal pool, coastal, etc.) through direct removal, filling, hydrological interruption, or other means?	<input checked="" type="checkbox"/>	<input type="checkbox"/>	<input type="checkbox"/>	<input checked="" type="checkbox"/>
d) Interfere substantially with the movement of any native resident or migratory fish or wildlife species or with established native resident or migratory wildlife corridors, or impeded the use of native wildlife nursery sites?	<input checked="" type="checkbox"/>	<input type="checkbox"/>	<input type="checkbox"/>	<input checked="" type="checkbox"/>
e) Conflict with any local policies or ordinances protecting biological resources, such as a tree preservation policy or ordinance?	<input checked="" type="checkbox"/>	<input type="checkbox"/>	<input type="checkbox"/>	<input checked="" type="checkbox"/>
f) Conflict with the provisions of an adopted Habitat Conservation Plan, Natural Community Conservation Plan, or other approved local, regional, or state habitat conservation plan?	<input checked="" type="checkbox"/>	<input type="checkbox"/>	<input type="checkbox"/>	<input checked="" type="checkbox"/>
<b>V. CULTURAL RESOURCES</b>				
Would the project:				
a) Cause a substantial adverse change in the significance of a historical resource as defined in §15064.5?	<input checked="" type="checkbox"/>	<input type="checkbox"/>	<input type="checkbox"/>	<input checked="" type="checkbox"/>
b) Cause a substantial adverse change in the significance of an archaeological resource pursuant to §15064.5?	<input checked="" type="checkbox"/>	<input checked="" type="checkbox"/>	<input type="checkbox"/>	<input type="checkbox"/>
c) Directly or indirectly destroy a unique paleontological resource or site or unique geologic feature?	<input checked="" type="checkbox"/>	<input checked="" type="checkbox"/>	<input type="checkbox"/>	<input type="checkbox"/>
d) Disturb any human remains, including those interred outside of formal cemeteries?	<input type="checkbox"/>	<input checked="" type="checkbox"/>	<input checked="" type="checkbox"/>	<input type="checkbox"/>
<b>VI. GEOLOGY AND SOILS</b>				
Would the project:				
a) Expose people or structures to potential substantial adverse effects, including the risk of loss, injury, or death involving:	<input checked="" type="checkbox"/>	<input type="checkbox"/>	<input type="checkbox"/>	<input type="checkbox"/>
i) Rupture of a known earthquake fault, as delineated on the most recent Alquist-Priolo Earthquake Fault Zoning Map issued by the State Geologist for the area or based on other substantial evidence of a known fault? Refer to Division of Mines and Geology Special Publication 42.	<input checked="" type="checkbox"/>	<input type="checkbox"/>	<input checked="" type="checkbox"/>	<input type="checkbox"/>
ii) Strong seismic ground shaking?	<input checked="" type="checkbox"/>	<input checked="" type="checkbox"/>	<input type="checkbox"/>	<input type="checkbox"/>
iii) Seismic-related ground failure, including liquefaction?	<input checked="" type="checkbox"/>	<input type="checkbox"/>	<input checked="" type="checkbox"/>	<input type="checkbox"/>
iv) Landslides?	<input checked="" type="checkbox"/>	<input checked="" type="checkbox"/>	<input type="checkbox"/>	<input type="checkbox"/>

Appendix A -  
Environmental Checklist Form

	Potentially Significant Impact	Less Than Significant With Mitigation Incorporated	Less than Significant Impact	No Impact
b) Result in substantial soil erosion or the loss of topsoil?	<input checked="" type="checkbox"/>	<input checked="" type="checkbox"/>	<input type="checkbox"/>	<input type="checkbox"/>
c) Be located on a geologic unit or soil that is unstable, or that would become unstable as a result of the project and potentially result in on- or off-site landslide, lateral spreading, subsidence, liquefaction or collapse?	<input checked="" type="checkbox"/>	<input checked="" type="checkbox"/>	<input type="checkbox"/>	<input type="checkbox"/>
d) Be located on expansive soil, as defined in Table 18- 1-B of the Uniform Building Code (1994), creating substantial risks to life or property?	<input checked="" type="checkbox"/>	<input type="checkbox"/>	<input checked="" type="checkbox"/>	<input type="checkbox"/>
e) Have soils incapable of adequately supporting the use septic tanks or alternative waste water disposal systems where sewers are not available for the disposal of waste water?	<input checked="" type="checkbox"/>	<input type="checkbox"/>	<input type="checkbox"/>	<input checked="" type="checkbox"/>
<b>VII. HAZARDS AND HAZARDOUS MATERIALS</b>				
Would the project:				
a) Create a significant hazard to the public or the environment through routine transport, use, or disposal of hazardous materials?	<input type="checkbox"/>	<input type="checkbox"/>	<input type="checkbox"/>	<input checked="" type="checkbox"/>
b) Create a significant hazard to the public or the environment through reasonably foreseeable upset and accident conditions involving the release of hazardous materials into the environment?	<input checked="" type="checkbox"/>	<input checked="" type="checkbox"/>	<input type="checkbox"/>	<input type="checkbox"/>
c) Emit hazardous emissions or handle hazardous or acutely hazardous materials, substances, or waste within one-quarter mile of an existing or proposed school?	<input checked="" type="checkbox"/>	<input checked="" type="checkbox"/>	<input type="checkbox"/>	<input type="checkbox"/>
d) Be located on a site which is included on a list of hazardous materials sites which complied pursuant to Government Code Section 65962.5 and, as a result, would it create a significant hazard to the public or the environment?	<input type="checkbox"/>	<input type="checkbox"/>	<input type="checkbox"/>	<input checked="" type="checkbox"/>
e) For a project within an airport land use plan or, where such a plan has not been adopted, within two miles of a public airport or public use airport, would the project result in a safety hazard for people residing or working in the project area?	<input type="checkbox"/>	<input type="checkbox"/>	<input type="checkbox"/>	<input checked="" type="checkbox"/>
f) For a project within the vicinity of a private airstrip, would the project result in a safety hazard for people residing or working in the project area?	<input type="checkbox"/>	<input type="checkbox"/>	<input type="checkbox"/>	<input checked="" type="checkbox"/>
g) Impair implementation of or physically interfere with an adopted emergency response plan or emergency evacuation plan?	<input checked="" type="checkbox"/>	<input type="checkbox"/>	<input type="checkbox"/>	<input checked="" type="checkbox"/>
h) Expose people or structures to a significant risk of loss, injury or death involving wildland fires, including where wildlands are adjacent to urbanized areas or where residences are intermixed with wildlands?	<input checked="" type="checkbox"/>	<input type="checkbox"/>	<input checked="" type="checkbox"/>	<input type="checkbox"/>
<b>VIII. HYDROLOGY AND WATER QUALITY</b>				
Would the project:				
a) Violate any water quality standards or waste discharge requirements?	<input checked="" type="checkbox"/>	<input checked="" type="checkbox"/>	<input type="checkbox"/>	<input type="checkbox"/>

Appendix A -  
Environmental Checklist Form

	Potentially Significant Impact	Less Than Significant With Mitigation Incorporated	Less than Significant Impact	No Impact
b) Substantially deplete groundwater supplies or interfere substantially with groundwater recharge such that there would be a net deficit in aquifer volume or a lowering of the local groundwater table level (e.g., the production rate of pre-existing nearby wells would drop to a level which would not support existing land uses or planned uses for which permits have been granted)?	<input checked="" type="checkbox"/>	<input type="checkbox"/>	<input type="checkbox"/>	<input checked="" type="checkbox"/>
c) Substantially alter the existing drainage pattern of the site or area, including through the alteration of the course of a stream or river, in a manner which would result in substantial erosion or siltation on- or off-site?	<input checked="" type="checkbox"/>	<input type="checkbox"/>	<input checked="" type="checkbox"/>	<input type="checkbox"/>
d) Substantially alter the existing drainage pattern of the site or area, including through the alteration of a course of a stream or river, or substantially increase the rate or amount of surface runoff in a manner which would result in flooding on or off-site?	<input checked="" type="checkbox"/>	<input type="checkbox"/>	<input checked="" type="checkbox"/>	<input type="checkbox"/>
e) Create or contribute runoff water which would exceed the capacity of existing or planned storm water drainage systems or provide substantial additional sources of polluted runoff?	<input checked="" type="checkbox"/>	<input checked="" type="checkbox"/>	<input type="checkbox"/>	<input type="checkbox"/>
f) Otherwise substantially degrade water quality?	<input checked="" type="checkbox"/>	<input checked="" type="checkbox"/>	<input type="checkbox"/>	<input type="checkbox"/>
g) Place housing within a 100-year flood hazard area as mapped on a federal Flood Hazard Boundary or Flood Insurance Rate Map or other flood hazard delineation map?	<input type="checkbox"/>	<input type="checkbox"/>	<input type="checkbox"/>	<input checked="" type="checkbox"/>
h) Place within a 100-year flood hazard area structures which would impede or redirect flood flows?	<input checked="" type="checkbox"/>	<input type="checkbox"/>	<input type="checkbox"/>	<input checked="" type="checkbox"/>
i) Expose people or structures to a significant risk of loss, injury or death involving flooding, including flooding as a result of the failure of a levee or dam?	<input checked="" type="checkbox"/>	<input type="checkbox"/>	<input type="checkbox"/>	<input checked="" type="checkbox"/>
j) Inundation by seiche, tsunami, or mudflow?	<input checked="" type="checkbox"/>	<input type="checkbox"/>	<input type="checkbox"/>	<input checked="" type="checkbox"/>
k) Result in an increase in pollutant discharges to receiving waters? Consider water quality parameters such as temperature, dissolved oxygen, turbidity and other typical storm water pollutants (e.g. heavy metals, pathogens, petroleum derivatives, synthetic organics, sediment, nutrients, oxygen-demanding substances, and trash.	<input checked="" type="checkbox"/>	<input checked="" type="checkbox"/>	<input type="checkbox"/>	<input type="checkbox"/>
l) Result in significant alteration of receiving water quality during or following construction?	<input checked="" type="checkbox"/>	<input checked="" type="checkbox"/>	<input type="checkbox"/>	<input type="checkbox"/>
m) Could the proposed project result in increased erosion downstream?	<input checked="" type="checkbox"/>	<input checked="" type="checkbox"/>	<input type="checkbox"/>	<input type="checkbox"/>
n) Result in increased impervious surfaces and associated increased runoff?	<input checked="" type="checkbox"/>	<input checked="" type="checkbox"/>	<input type="checkbox"/>	<input type="checkbox"/>
o) Create a significant adverse environmental impact to drainage patterns due to changes in runoff flow rates or volumes?	<input checked="" type="checkbox"/>	<input checked="" type="checkbox"/>	<input type="checkbox"/>	<input type="checkbox"/>
p) Tributary to an already impaired water body, as listed on Clean Water Act Section 303(d) list? If so, can it result in an increase in any pollutant for which the water body is already impaired?	<input checked="" type="checkbox"/>	<input checked="" type="checkbox"/>	<input type="checkbox"/>	<input type="checkbox"/>
q) Tributary to other environmentally sensitive areas? If so, can it exacerbate already existing sensitive conditions?	<input checked="" type="checkbox"/>	<input checked="" type="checkbox"/>	<input type="checkbox"/>	<input type="checkbox"/>
r) Have a potentially significant environmental impact on surface water quality to either marine, fresh, or wetland waters?	<input checked="" type="checkbox"/>	<input checked="" type="checkbox"/>	<input type="checkbox"/>	<input checked="" type="checkbox"/>

Appendix A -  
Environmental Checklist Form

	Potentially Significant Impact	Less Than Significant With Mitigation Incorporated	Less than Significant Impact	No Impact
s) Have a potentially significant adverse impact on groundwater quality?	<input checked="" type="checkbox"/>	<input checked="" type="checkbox"/>	<input type="checkbox"/>	<input type="checkbox"/>
t) Cause or contribute to an exceedance of applicable surface or groundwater receiving water quality objectives or degradation of beneficial uses?	<input checked="" type="checkbox"/>	<input checked="" type="checkbox"/>	<input type="checkbox"/>	<input type="checkbox"/>
u) Impact aquatic, wetland, or riparian habitat?	<input checked="" type="checkbox"/>	<input checked="" type="checkbox"/>	<input type="checkbox"/>	<input type="checkbox"/>
<b>IX. LAND USE AND PLANNING</b>				
Would the proposal:				
a) Physically divide an established community?	<input type="checkbox"/>	<input type="checkbox"/>	<input type="checkbox"/>	<input checked="" type="checkbox"/>
b) Conflict with any applicable land use plan, policy, or regulation of an agency with jurisdiction over the project (including, but not limited to the general plan, specific plan, local coastal program, or zoning ordinance) adopted for the purpose of avoiding or mitigating an environmental effect?	<input checked="" type="checkbox"/>	<input type="checkbox"/>	<input type="checkbox"/>	<input checked="" type="checkbox"/>
c) Conflict with any applicable habitat conservation plan or natural community conservation plan?	<input checked="" type="checkbox"/>	<input type="checkbox"/>	<input type="checkbox"/>	<input checked="" type="checkbox"/>
<b>X. MINERAL RESOURCES</b>				
Would the project:				
a) Result in the loss of availability of a known mineral resource that would be of value to the region and the residents of the state?	<input type="checkbox"/>	<input type="checkbox"/>	<input type="checkbox"/>	<input checked="" type="checkbox"/>
b) Result in the loss of availability of a locally-important mineral resource recovery site delineated on a local general plan, specific plan, or other land use plan?	<input type="checkbox"/>	<input type="checkbox"/>	<input type="checkbox"/>	<input checked="" type="checkbox"/>
<b>XI. NOISE</b>				
Would the project result in:				
a) Exposure of persons to or generation of noise levels in excess of standards established in the local general plan or noise ordinance, or applicable standards of other agencies?	<input checked="" type="checkbox"/>	<input checked="" type="checkbox"/>	<input type="checkbox"/>	<input type="checkbox"/>
b) Exposure of persons to or generation of excessive groundborne vibration or groundborne noise levels?	<input checked="" type="checkbox"/>	<input type="checkbox"/>	<input checked="" type="checkbox"/>	<input type="checkbox"/>
c) A substantial permanent increase in ambient noise levels in the project vicinity above levels existing without the project?	<input checked="" type="checkbox"/>	<input type="checkbox"/>	<input checked="" type="checkbox"/>	<input type="checkbox"/>
d) A substantial temporary or periodic increase in ambient noise levels in the project vicinity above levels existing without the project?	<input checked="" type="checkbox"/>	<input checked="" type="checkbox"/>	<input type="checkbox"/>	<input type="checkbox"/>
e) For a project located within an airport land use land use plan or, where such a plan has not been adopted, within two miles of a public airport or public use airport, would the project expose people residing or working in the project area to excessive noise levels?	<input type="checkbox"/>	<input type="checkbox"/>	<input type="checkbox"/>	<input checked="" type="checkbox"/>
f) For a project within the vicinity of a private airstrip, would the project expose people residing or working in the project area to excessive noise levels?	<input type="checkbox"/>	<input type="checkbox"/>	<input type="checkbox"/>	<input checked="" type="checkbox"/>

Appendix A -  
Environmental Checklist Form

	Potentially Significant Impact	Less Than Significant With Mitigation Incorporated	Less than Significant Impact	No Impact
<b>XII. POPULATION AND HOUSING</b>				
Would the project:				
a) Induce substantial population growth in an area, either directly (for example, by proposing new homes and businesses) or indirectly (for example, through extension of roads or other infrastructure)?	<input type="checkbox"/>	<input type="checkbox"/>	<input type="checkbox"/>	<input checked="" type="checkbox"/>
b) Displace substantial numbers of existing housing, necessitating the construction of replacement housing elsewhere?	<input type="checkbox"/>	<input type="checkbox"/>	<input type="checkbox"/>	<input checked="" type="checkbox"/>
c) Displace substantial numbers of people, necessitating the construction of replacement housing elsewhere?	<input type="checkbox"/>	<input type="checkbox"/>	<input type="checkbox"/>	<input checked="" type="checkbox"/>
<b>XIII. PUBLIC SERVICES</b>				
a) Would the project result in substantial adverse physical impacts associated with the provision of new or physically altered government facilities, need for new or physically altered government facilities, the construction of which could cause significant environmental impacts, in order to maintain acceptable service ratios, response times or other performance objectives for any of the public services:	<input checked="" type="checkbox"/>	<input type="checkbox"/>	<input checked="" type="checkbox"/>	<input type="checkbox"/>
i. Fire protection?	<input checked="" type="checkbox"/>	<input type="checkbox"/>	<input checked="" type="checkbox"/>	<input type="checkbox"/>
ii. Police protection?	<input checked="" type="checkbox"/>	<input type="checkbox"/>	<input type="checkbox"/>	<input checked="" type="checkbox"/>
iii. Schools?	<input type="checkbox"/>	<input type="checkbox"/>	<input type="checkbox"/>	<input checked="" type="checkbox"/>
iv. Parks?	<input checked="" type="checkbox"/>	<input type="checkbox"/>	<input type="checkbox"/>	<input checked="" type="checkbox"/>
v. Other public facilities?	<input checked="" type="checkbox"/>	<input type="checkbox"/>	<input type="checkbox"/>	<input checked="" type="checkbox"/>
<b>XIV. RECREATION</b>				
a) Would the project increase the use of existing neighborhood and regional parks or other recreational facilities such that substantial physical deterioration of the facility would occur or be accelerated?	<input checked="" type="checkbox"/>	<input type="checkbox"/>	<input type="checkbox"/>	<input checked="" type="checkbox"/>
b) Does the project include recreational facilities or require the construction of or expansion of recreational facilities which might have an adverse physical effect on the environment?	<input type="checkbox"/>	<input type="checkbox"/>	<input type="checkbox"/>	<input checked="" type="checkbox"/>
<b>XV. TRANSPORTATION/TRAFFIC</b>				
Would the project:				
a) Cause an increase in traffic which is substantial in relation to the existing traffic load and capacity of the street system (i.e., result in a substantial increase in either the number of vehicle trips, the volume to capacity ratio on roads, or congestion at intersections)?	<input checked="" type="checkbox"/>	<input type="checkbox"/>	<input checked="" type="checkbox"/>	<input type="checkbox"/>
b) Exceed either individually or cumulatively, a level of service standard established by the county congestion management agency for designated roads or highways?	<input checked="" type="checkbox"/>	<input type="checkbox"/>	<input checked="" type="checkbox"/>	<input type="checkbox"/>
c) Result in a change in air traffic patterns, including either an increase in traffic levels or a change in location that results in substantial safety risks?	<input type="checkbox"/>	<input type="checkbox"/>	<input type="checkbox"/>	<input checked="" type="checkbox"/>
d) Substantially increase hazards due to a design feature (e.g., sharp curves or dangerous intersections) or incompatible uses (e.g., farm equipment)?	<input checked="" type="checkbox"/>	<input type="checkbox"/>	<input type="checkbox"/>	<input checked="" type="checkbox"/>
e) Result in inadequate emergency access?	<input checked="" type="checkbox"/>	<input type="checkbox"/>	<input type="checkbox"/>	<input checked="" type="checkbox"/>



Appendix A -  
Environmental Checklist Form

	Potentially Significant Impact	Less Than Significant With Mitigation Incorporated	Less than Significant Impact	No Impact
f) Result in inadequate parking capacity?	<input checked="" type="checkbox"/>	<input checked="" type="checkbox"/>	<input type="checkbox"/>	<input type="checkbox"/>
g) Conflict with adopted policies, plans, or programs supporting alternative transportation (e.g., bus turnouts, bicycle racks)?	<input checked="" type="checkbox"/>	<input type="checkbox"/>	<input type="checkbox"/>	<input checked="" type="checkbox"/>
<b>XVI. UTILITIES &amp; SERVICE SYSTEMS</b>				
Would the project:				
a) Exceed wastewater treatment requirements of the applicable Regional Water Quality Control Board?	<input checked="" type="checkbox"/>	<input type="checkbox"/>	<input checked="" type="checkbox"/>	<input type="checkbox"/>
b) Require or result in the construction of new water or wastewater treatment facilities or expansion of existing facilities, the construction of which could cause significant environmental effects?	<input checked="" type="checkbox"/>	<input type="checkbox"/>	<input checked="" type="checkbox"/>	<input type="checkbox"/>
c) Require or result in the construction of new storm water drainage facilities or expansion of existing facilities, the construction of which could cause significant environmental effects?	<input checked="" type="checkbox"/>	<input type="checkbox"/>	<input checked="" type="checkbox"/>	<input type="checkbox"/>
d) Have sufficient water supplies available to serve the project from existing entitlements and resources, or are new or expanded entitlements needed?	<input checked="" type="checkbox"/>	<input type="checkbox"/>	<input checked="" type="checkbox"/>	<input type="checkbox"/>
e) Result in a determination by the wastewater treatment provider, which serves or may serve the project that it has adequate capacity to serve the project's projected demand in addition to the provider's existing commitments?	<input checked="" type="checkbox"/>	<input type="checkbox"/>	<input checked="" type="checkbox"/>	<input type="checkbox"/>
f) Be served by a landfill with sufficient permitted capacity to accommodate the project's solid waste disposal needs?	<input checked="" type="checkbox"/>	<input type="checkbox"/>	<input checked="" type="checkbox"/>	<input type="checkbox"/>
g) Comply with federal, state, and local statutes and regulations related to solid waste?	<input checked="" type="checkbox"/>	<input type="checkbox"/>	<input type="checkbox"/>	<input checked="" type="checkbox"/>
<b>XVII. MANDATORY FINDINGS OF SIGNIFICANCE.</b>				
A) Does the project have the potential to degrade the quality of the environment, substantially reduce the habitat of a fish or wildlife species, cause a fish or wildlife population to drop below self-sustaining levels, threaten to eliminate a plant or animal community, reduce the number or restrict the range of a rare or endangered plant or animal or eliminate important examples of the major period of California history or prehistory?	<input checked="" type="checkbox"/>	<input checked="" type="checkbox"/>	<input type="checkbox"/>	<input type="checkbox"/>
b) Does the project have the potential to achieve short-term environmental goals to the disadvantage of long-term environmental goals?	<input type="checkbox"/>	<input type="checkbox"/>	<input type="checkbox"/>	<input checked="" type="checkbox"/>
c) Does the project have impacts that are individually limited, but cumulatively considerable? ("Cumulatively considerable" means that the incremental effects of a project are considerable when viewed in connection with the effects of past projects, the effects of other current projects, and the effects of probable future projects.)	<input checked="" type="checkbox"/>	<input type="checkbox"/>	<input type="checkbox"/>	<input checked="" type="checkbox"/>
d) Does the project have environmental effects which will cause substantial adverse effects on human beings, either directly or indirectly?	<input checked="" type="checkbox"/>	<input checked="" type="checkbox"/>	<input type="checkbox"/>	<input type="checkbox"/>

**XVII. EARLIER ANALYSES.**

Earlier analyses may be used where, pursuant to the tiering, program EIR, or other CEQA process, one or more effects have been adequately analyzed in an earlier EIR or negative declaration. Section 15063(c)(3)(D). In this case a discussion should identify the following on attached sheets:

- a) Earlier analyses used. Identify earlier analyses and state where they are available for review.
- b) Impacts adequately addressed. Identify which effects from the above checklist were within the scope of and adequately analyzed in an earlier document pursuant to applicable legal standards, and state whether such effects were addressed by mitigation measures based on the earlier analysis.
- ~~c) Mitigation measures. For effects that are "Less than Significant with Mitigation Incorporated," describe the mitigation measures, which were incorporated or refined from the earlier document and the extent to which they address site-specific conditions for the project.~~

## Source List

The following enumerated documents are available at the offices of the City of Dana Point, Community Development Department, 33282 Golden Lantern, Suite 212, Dana Point, CA 92629.

1. California Environmental Quality Act as amended January 1, 2008. §§21000-21178 of the *Public Resources Code*, State of California.
2. Guidelines for California Environmental Quality Act as amended July 27, 2007. §15000-15387 of the California Code of Regulations, Title 14, Chapter 3, State of California.
3. South Shores Church Master Plan, Project Plans prepared by Matlock Associates, Inc., dated May 2008.
4. City of Dana Point General Plan, approved July 9, 1991.
5. ~~South Shores Church Master Plan, Conceptual Water Quality Management Plan, prepared by Adams-Streeter Civil Engineers, Inc. dated January 25, 2008.~~
6. South Shores Church Master Plan, Hydrology/Drainage Analysis prepared by Adams-Streeter Civil Engineers, Inc. dated September 2008.
7. South Shores Church Master Plan, Geotechnical Study prepared by G.A. Nicoll and Associates, Inc. dated February 20, 2008 and April 6, 2006.
8. South Shores Church Master Plan, Report of Supplemental Geotechnical Investigation for the Proposed Christian Education Buildings 1 and 2, prepared by G.A. Nicoll and Associates, Inc., dated May 21, 2007.
9. South Shores Church Master Plan, Response to Geotechnical Review prepared by G.A. Nicoll and Associates, Inc., dated November 28, 2007, October 31, 2007, and July 26, 2007.

The following enumerated documents are available in "Appendix B" of this document:

1. South Shores Church Master Plan, Air Quality Study prepared by Mestre Greve Associates, Inc. dated April 2006 and updated May 2008 and November 2008.
2. South Shores Church Master Plan, Parking and Traffic Study, prepared by RK Engineering Group, Inc. dated May 9, 2006 and updated May 12, 2008.
3. South Shores Church Master Plan, Biological Resources Assessment, prepared by Califauna (Jeffrey B. Froke, Ph.D.), dated October 30, 2007, April 25, 2008, and January 8, 2009.
4. South Shores Church Master Plan, Noise Study prepared by Mestre Greve Associates, Inc. dated April 2006 and updated May 2008 and November 2008.

Historical documents showing  
unresolved title discrepancies

1962

The site is too small for the project:

A preliminary review of title and variance documents for the project site, circa February 21, 1962, shows that the developer acquired a parcel measured 375 feet deep from the easterly side of Crown Valley as it then existed, said parcel containing 6.0 acres. As early as 1962, the developer attempted to claim more property, as noted by the Orange County Planning Commission, by using plats for development inconsistent with their title. Currently, the project architect asserts that his plats show the property line at the edge of the sidewalk and extending to the east the same 375 feet. As Crown Valley has tripled in width since the 1960s, all to the east, it is highly improbable that the developer acquired a parcel with a property line some 50-100 feet to the east of the road, particularly in light of the documented objection by the developer to the widening of Crown Valley on the developer's land.

We therefore request that the EIR evaluate the entire chain of title and then conduct a complete title survey. If the westerly edge of the property sites in the middle of Crown Valley as we believe the Commission thought in 1962, and if the property is 375 deep from that point, then the existing sanctuary sits beyond their property line. The survey will also show that the entire slope, the entire bluff, the site of the proposed retaining wall, the site of the bluff destruction and bluff excavation, and the new buildings will be on land not owned by the developer.

On the other hand, if the proper property line is 375 feet east of the sidewalk as asserted by the project architect, the eastern 75+ feet of the site are actually within, not simply abutting, the Monarch Beach Resort Specific Plan.

The historical documents attached hereto, as well as raising the significant title questions, demonstrate that the church began its overbuilding development with a pledge to have a capacity not to exceed 125 parishioners and 45 parking spaces by a variance to R-1 Zoning. Nothing has changed to justify a larger occupancy load on the site.

MINUTES

ORANGE COUNTY PLANNING COMMISSION MEETING - FEBRUARY 21, 1962

PUBLIC HEARING:

TAPE NO. 25, RECORDING INDEX: 0221.

SD C-988, OF SOUTH SHORES BAPTIST CHURCH, BETWEEN THREE ARCH BAY AND DANA POINT.

Location: Approximately 2000 feet north and east of Coast Highway on the easterly side of a 40 foot easement extension of Crown Valley Highway between Three Arch Bay and Dana Point.

Request: To permit the establishment of a church in the R1 Single Family Residence and C1 Local Business District, according to application on file.

COMMISSION ACTION: 0249: Public hearing continued until meeting of March 21, 1962, on motion of Barnes.

A report was read from the County Highway Department recommending that the applicant agree to arrange for the dedication of the easterly half of Crown Valley Highway, which through the recent recording of Tract No. 4269 exists as only a half street on the westerly side and, also, that the applicant improve said dedication with concrete curbs, gutters, drive approach, sidewalks and paving from the gutters to the center line of the road in accordance with County standards in a manner meeting the approval of the Road Commissioner.

A report was received from the County Department of Building and Safety pointing out that a discrepancy exists between the legal description and the plot plan and recommending that the plot plan be adjusted to accurately reflect the provisions of the legal description.

A letter was read from Cabot, Cabot and Forbes, Incorporated stating that their approval of the church site was based on the church's agreement by acceptance of this letter not to object to Laguna Niguel's shopping center with the uses permitted by the Zoning Code.

Mr. R. A. Cole was present representing this application and commented on the Building Department's letter regarding the legal description for access to the property. He stated that it was his understanding that Crown Valley Highway would be improved by Laguna Niguel.

The Commission commented on the inadequate plot plan that was submitted with this application and felt that a new plan should be submitted before any action was taken on this case.

(Continued on next page)

**MINUTES**  
ORANGE COUNTY PLANNING COMMISSION MEETING - FEBRUARY 21, 1962

**PUBLIC HEARING:**

P.C. TAPE NO. 25, RECORDING INDEX: 0221.

58D C-988, OF SOUTH SHORES BAPTIST CHURCH, BETWEEN THREE ARCH BAY AND DANA POINT (CONTINUED).

Department of Building and Safety representative Nelson stated that an inspection had been made concerning the public safety requirements of this dwelling for a church.

It was the consensus of the Commission that the applicants consult with the representatives of Laguna Miguel regarding the improvement of Crown Valley Highway and submit further information on this road when a new plot plan is submitted.

I HEREBY CERTIFY THAT THIS IS A TRUE COPY OF AN EXCERPT FROM THE MINUTES OF THE ORANGE COUNTY PLANNING COMMISSION.



Cary E. Borch, Secretary

APPLICATION FOR **CONDITIONAL PERMIT**

UNDER ORDINANCE NO. 601, AS AMENDED,  
COUNTY OF ORANGE, CALIFORNIA

No. CP 788  
APPROVED BY: [Signature]  
DATE: 11-25-70  
REASON FOR DENIAL: [Blank]  
TECHNICAL: [Blank]  
S.P.M. NO. [Blank]  
RECEIVED TO: [Blank]

South Shores Baptist Church P.O. Box 74, Laguna Beach  
Richard A. Cole 304 Cliff Drive, Laguna Beach HY 4-1982

TO PERMIT the establishment of a church in the R1 Single Family Residence District.

Said church will be in the existing dwelling, detached garage and guest house on the premises.

Said church will accommodate a maximum of 125 persons.

Off-street parking will be provided for 45 cars as indicated on the attached plot plan.

There will be one double-faced sign containing a maximum area of 20 sq. ft. on each face located on the front property line and northerly of the drive entrance as indicated.

*Intentional address  
32110 Crown Valley Parkway  
12-1-70*

AP # 670-011-06

All in accordance with the attached plot plan which is hereby made a part hereof. In any case of conflict between the language of this application and the plot plan, the plot plan shall prevail.

LEGAL DESCRIPTION OF SUBJECT PROPERTY: See attached sheet.

Location of property: Approximately 2000 ft. north and east of Coast Highway on the easterly side of a 40 ft. easement extension of Crown Valley Highway between Three Arch Bay and Dana Point.

Present use of property: Dwelling and detached garage with guest quarters.

Adjoining property owned or leased by applicant: None.

11-25-70  
**GRANTED**  
**WITH**  
**CONDITIONS**

BY ACTION OF THE  
PLANNING COMMISSION

*Richard A. Cole*  
Richard A. Cole  
Mayor of City of Laguna Beach

No. CP 788



Additional pictures of relevance to the project  
are attached.

.



This photo shows the Salt Creek Trail and Corridor from Camino del Avion bridge. The church is shown at upper right. The view impairment resulting from building onto the slope is apparent.



Dirt that has been removed from one section of the Salt Creek Trail after early 2010 rains.



This is the former Expo Center on Rancho Niguel Road in Laguna Niguel. It is available and would be an ideal off-site location for the SSBC to purchase.

NOTE: Part of the expansion is on the steep slope and includes an additional 35 feet of encroachment allocated to the playground.

**Detail area**  
Stonehill Dr.  
Selva Rd.  
**DANA POINT**

# Planned expansion

... ..

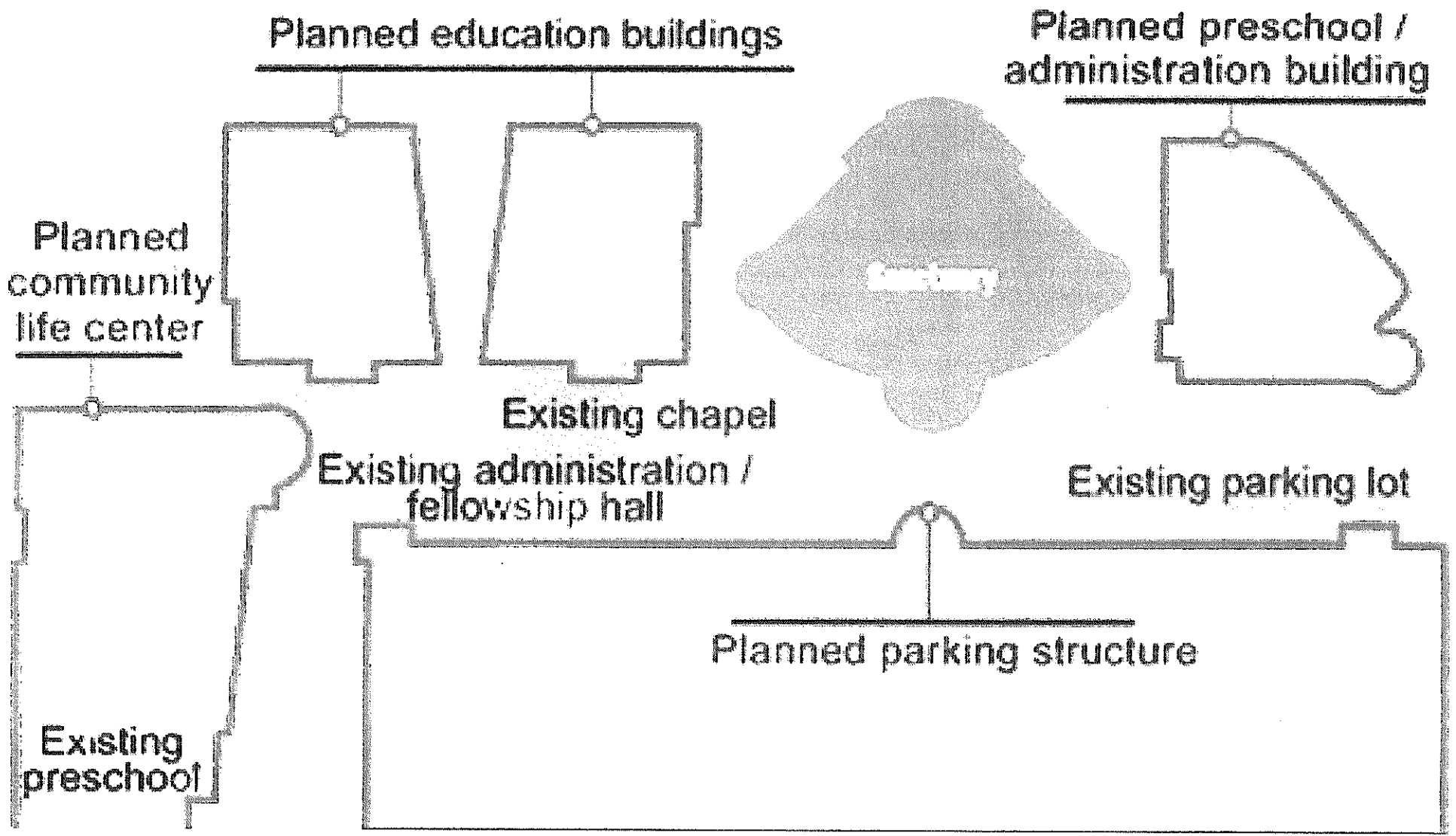

**Church's location above the landslide area  
where two apartment building were destroyed  
Site was never rebuilt**

**looking south from overpass on  
Camino del Avion  
Todd Glen - Photographer**



# SAINT-AUBIN MEDIATION

---

ROBERT F. SAINT-AUBIN  
MEDIATOR • ARBITRATOR • ATTORNEY  
53 CASSIS • MONARCH BEACH • CA 92629  
949-466-2400 • FAX 949-496-5075  
RFSAINTE@SLOAN.MIT.EDU

July 15, 2009

Ms. Erica H. Demkowicz, AICP  
Senior Planner  
City of Dana Point, Community Development Department  
33282 Golden Lantern  
Dana Point, CA 92629

**RECEIVED**

JUL 15 2009

CITY OF DANA POINT  
COMMUNITY DEVELOPMENT  
DEPARTMENT

Re: **SOUTH SHORES CHURCH MASTER PLAN**

Dear Ms. Demkowicz:

Attached hereto and incorporated herein are our comments supplementing our comments filed in May with respect to the Proposed Master Plan for the South Shores Church reconstruction. We respectfully request that the Planning Commission members view the Salt Creek View Corridor and the church site from the rear yards of the homes on Cassis. To that end, you, the staff and the Commissioners are welcome to visit here at 53 Cassis.

Very truly yours,



REVISED AFTER FILING

**SUPPLEMENTAL COMMENTS IN OPPOSITION TO  
SOUTH SHORES BAPTIST CHURCH  
PROPOSED MASTER PLAN**

To mitigate the oversized project toward Crown Valley, the consultants propose digging into the hilltop to remove 100,000 cubic yards of earth. In doing so the project will violate all of the policies and mandates with respect to the Salt Creek Scenic Corridor contained in the Dana Point and Monarch Beach Plans, plans which prohibit changing contours, building retaining walls, building on slide areas, building adjacent to bluffs, building on cliff tops, and removing ancient vegetation. The plan fails to adequately account for untreated storm water runoff from the property discharged to Salt Creek and the Pacific Ocean. These violations create unnecessary dust and noise pollution, adversely impacting the Monarch Beach communities for the next ten years and continuing thereafter.

**I. INTRODUCTION**

I am an environmental attorney and mediator with an undergraduate degree from MIT. Although secretary for the Corniche Sur Mer HOA, I am here only on behalf of myself and my wife. We love the church, and having recently met Pastor Ty and his gracious wife, we are fond of them as well.

We share with the church a natural amphitheater in the finest Greco-Roman tradition. They are the stage, we the audience. Their whispers ring in our ears, their parties and celebrations permeate our bedroom.

In my original filed comments, I addressed at length the failure of the church consultants and the Planning Department to consider, let alone mitigate, the problems and disruptions to the east. I ask you to carefully read and review those comments.



The church consultants' simplistic response to my detailed and comprehensive comments was repetition of the refrain: he's beyond 500 feet, so we do not have to consider his points. Well, I pay real estate taxes based upon a value grossly inflated by my proximity to the church property and the scenic corridor existing between the church and me. We are less than 1000 feet away, directly across an open canyon that functions as an amphitheater, amplifying all sound emanating from the site, and also in the direction of the prevailing winds, carrying the dirt and dust unnecessarily generated by the oversized project.

Until May 2009, we were not notified of this project by the church, the church consultants or the City of Dana Point. We had no opportunity to interact and have our legitimate concerns addressed. As a professional mediator, I can assure you that had I been consulted earlier, I could have helped find meaningful solutions to *all* of the impacted interests. Because they chose to ignore us throughout the project process, we can now only offer our lawful objections to their failure to follow the requirements of law and take such other appropriate legal action as we find necessary. Please send this project back to the drawing boards for evaluation of the adverse impacts on the ignored Salt Creek View Corridor and for recalculation of floor area ratio (FAR), including all structures on the property.

The visual simulations in the proposed master plan (PMP) do not reflect the actual impacts of the project.

## **II. PROJECT MITIGATED TO TRAFFIC ON CROWN VALLEY PARKWAY**

The PMP makes much ado about the Crown Valley Parkway Scenic Corridor, expressing great concern about views across the site from vehicles moving at 35-50 mph, and complementing themselves on their action to mitigate their worries about the CVP Scenic Corridor. At the same time, they totally ignored the more important adjacent Salt Creek Scenic Corridor, containing Salt Creek, the Salt Creek Canyon, the Salt Creek Park, the Salt Creek Trail, a designated wilderness area, steep cliffs and bluffs, a known landslide area and the Monarch Beach Golf Links, all of which are within the requisite 500 feet to the east. The project starts

by removing ancient vegetation on the ridge framing the Salt Creek Scenic Corridor.

While arguably recognizing the need to mitigate for the benefit of the neighbors to the north, south and west, they failed to mitigate any of the acknowledged major problems to the east.

Contrary to the mandates of the Dana Point General Plan, the PMP does not consider the real and serious impacts on the Salt Creek View Corridor.

### **Introduction to the General Plan**

#### **Coastline**

The coastline of Dana Point is an exceptional area where the interface between land and water can be experienced in different ways. With its combination of high coastal bluffs and coastal access where the San Juan and Salt Creek basins meet the ocean, both inhabitants and visitors to Dana Point have the opportunity to enjoy the coastline by viewing it from visual vantage points along the bluffs or further inland, or by utilizing community beaches and the Harbor. Maintaining these different ways of experiencing the attractions offered by a beautiful coastline setting is fundamental in the establishment of an image of Dana Point's future.

### **III. PROPERTY VALUES**

We live in a community valued, appraised and taxed at rates based upon the existence of open space, setting, including ocean views, and solitude, all to be destroyed by this unfinanced project. Will this site be the next to be added to orphaned, abandoned, incomplete projects like the scar of the apartment slide immediately to the north?

#### IV. PROJECT TOO BIG FOR SITE

**Public facilities Policy 5.9:** Ensure to the extent feasible that adequate sites are available for public facilities, churches, schools, museum(s), government offices, a civic/cultural center or other facilities that may serve the public interest.

The project is too big for the site. The site is not adequate for the proposed project. The City of Dana Point (CDP) Code and good practice allow maximum coverage of 35 percent and a Floor Area Ratio (FAR) of 0.41. The church and its consultants conveniently omit and ignore all dimensions on the largest structure on the site – the parking garage. Then they fail to include the omitted structure's floor area in their FAR calculations. We estimate the size of the parking structure as at least 138,000 square feet and as much as 200,000 square feet. We used their parking space count, multiplied by the minimum space and aisle sizes contained in the CDP Code. Add 200,000 to the acknowledged 97,000 square feet and divide by the net six acres (210,000 square feet) and we have a FAR significantly higher than the allowed .41. This project does not meet the special circumstances justifying a higher FAR number. The Dana Point Code defines FAR as total structures on the property divided by the net square feet. The church consultants failed to include total structures. The church consultants will wrongly assert that FAR does not count parking. The City Plan requires a lower density than Irvine, Newport Beach and Santa Ana, all of which have a .41 limit including parking structures. A look at the recently erected story poles shows that the project is too big for the site. As proposed it is ILLEGAL. If approved here it should not survive the City Council review, the Coastal Commission review, and judicial review.

An easy solution is to increase the entire project to three stories, significantly set back from the boundaries of the property.

Elevations presented with the PMP do not show the impact of a 25-foot retaining wall facing us. "Landscaping" does not constitute an adequate mitigation. Look around Dana Point at all of the existing "landscaped" retaining walls. With no operational irrigation, all the vegetation has quickly died. The General Plan

prohibits retaining walls on steep slopes. The proposed retaining wall will be constructed on a known slide and seismic area before completion of the geotechnical studies.

Not only is the project too big, but a ten-year construction life is inherently unreasonable with the chainlink or green mesh fences, earth-moving noise and indeterminate dust, particularly when residents face restrictions on our use of outdoor water to remove the church's dust.

#### **V. ENVIRONMENTAL IMPACT REPORT (EIR)**

At the very beginning of the project, the consultants failed to properly evaluate the environmental impacts. An honest evaluation would have checked "potentially significant impacts," which in virtually every category would have resulted in an automatic EIR, as was properly required for the much smaller and less significant Doheny House project. This project needs an EIR.

#### **VI. EXCESSIVE NOISE**

The consultants did not consider or address playground noise, which will be amplified and carry line of site across the Salt Creek Canyon, disturbing our tranquility for the rest of our lives. Construction noise and earth-moving noise will make habitation of our home, use of our patio and deck, and use of my home office impossible during normal business hours. The proposed playground should be surrounded by a 10-foot solid glass wall to contain the screaming kids and protect them from falling off the cliff. An even better solution would be to move the playground to the center of the project so the kiddy noise is surrounded by the structures. Move the chain link fence to the center of the property to protect the kiddies from the parking garage.

#### **VII. EXCESSIVE DUST AND AIR POLLUTION**

If the consultants properly calculated FAR and followed the applicable General Plan, Monarch Beach Plan and Salt Creek Scenic Corridor mandates for steep

slopes, bluffs and cliffs, they could not slice off the top of the ridge and not generate all of the dirt and dust that will blow across the canyon unceasingly for the next ten years. If they followed those mandates, they would not dig into the hillside and not generate the dust and dirt, dust and dirt that they acknowledge will be controlled by not more than 50 percent; unnecessary dust and dirt. Maintaining existing contours, as required by the General Plan, Monarch Beach Plan and Salt Creek Scenic Corridor requirements would totally mitigate the massive dust problem to the east. If build they must, they should build on top of the hill, not cut deeply into the hill. Following FAR will keep the project to a manageable size.

#### **VIII. GEOTECHNICAL ANALYSIS**

The church's geotechnical analysis fails to meet any standards of acceptability. The proposed buildings are a few feet (certainly less than five hundred) from a known major landslide; a landslide on property owned by their proposed builder-- a builder/owner who has elected to not rebuild following the landslide because he knows that he cannot safely build. Who is going to accept the liability when the overbuilt monolith slides into Salt Creek?

If the church and city maintained the existing contours and grade, a substantial part of the dirt, dust and construction noise could become a non-issue. The consultants intend to evaluate the known landslide problem after major destruction of terrain by their excavation and demolition. The proposed retaining wall, in violation of the Salt Creek Scenic Corridor Plans, will exacerbate the geotechnical slide problems, in addition to being ugly and unnatural.

#### **IX. PARKING**

Parking is critical but not funded and scheduled for the last phase. Will it ever happen? Using weekend beach parking for church services is inconsistent with the Coastal Plan. Where will the busses wait with their motors running every Sunday morning?

## X. CONCLUSION

The church and the City of Dana Point failed to look to the east. They said they do not have to because there is no housing within 500 feet to the east. We are in a direct, uninterrupted line of sight less than 1000 feet to the east. Between the church and us are the designated wilderness area, the Salt Creek Basin, the Salt Creek Canyon, the Salt Creek Scenic Corridor, the Salt Creek Park, and the Salt Creek Trail, all of which must receive special consideration in the planning stage that is totally ignored here. In failing to look east (other than for the purpose of enhancing their own views), the church and the City failed to give any consideration to the issues required to be addressed by the City of Dana Point General Plan. Below are excerpts from the Dana Point Plan with analytic comments that were either ignored or violated by the PMP.

### **LAND USE ELEMENT:**

Preservation of developed and undeveloped portions of the City which have cultural, social and natural resource value to the City and it's citizens;

Reduction of loss of life, injury and property damage that might occur as a result of natural hazards, such as flooding, seismic activity, soils erosion and storm waves, and man-made hazards, such as unsound construction, poor traffic patterns and roadway conditions, and incompatibility among different land uses.

*COMMENT: This parcel is subject to significant seismic activity in the form of land slides. The maximum density use is inconsistent with the Salt Creek View Corridor mandate.*

**Policy 1.1:** Develop standards for building intensity, including standards for ground coverage, setbacks, open space/landscaping, maximum dwellings per acre, floor area ratios, size and height restrictions.

*COMMENT: The project violates established building intensity, FAR and coverage requirements.*

**GOAL 2: Achieve compatibility and enhance relationships among land uses in the community.**

**Policy 2.1:** Consider the impacts on surrounding land uses and infrastructure when reviewing proposals for new development. (Coastal Act/30250)

*COMMENT: The consultants failed to consider anything and anybody to the east.*

**Policy 2.2:** Visitor serving commercial areas shall not intrude into existing residential communities. (Coastal Act/30250)

*COMMENT: This project, by sound, dirt and dust, mass and hydrologic disturbances, excessively intrudes on its residential neighbors to the south, west and east.*

**Policy 3.4:** Examine the short term and long term fiscal effects of development and revitalization decisions.

*COMMENT: This project will diminish by hundreds of thousands of dollars each the value of hundreds of million-dollar homes. The piecemeal "phased" construction is a euphemism for inadequate project funding. The church barely has funds to start the environmental destruction, let alone complete the final phases. The community facilities will be directly competing with taxpaying Monarch Beach hotel and restaurant meeting and reception facilities.*

**Policy 3.5:** Public facilities including parking areas or facilities shall, wherever appropriate and feasible, be distributed throughout the coastal zone area to mitigate against the impacts, social and otherwise, of overcrowding and overuse by the public of any single area. (Coastal Act/30212.5)

*COMMENT: The parking structure will have an unmitigated impact on all of these considerations. The use of beach parking lots will diminish the ability of weekend*

*beach users to park at the beach. No mitigation was made for the busses to “idle” after transporting congregants to services.*

## **PRESERVATION OF NATURAL RESOURCES**

Portions of the City consist of fragile coastal beaches and bluffs, hillsides, and canyons which are sensitive to changes associated with land development. These fragile areas provide an important sense of place and openness. Preservation of such areas provides a physical buffer protecting persons and improvements from natural and man-made safety hazards. These areas also present opportunities for passive recreation, such as trails for bicycling and hiking, which result in only minimal disruption to sensitive lands. In the General Plan, bluff demarcation is drawn based on a mean estimation projected across all parcels impacted by coastal bluff areas. The specific location of the bluff line, as it is applied to an individual parcel, will be established consistent with existing policies and criteria in effect when building plans are submitted.

*COMMENT: The retaining wall accompanied by ridge and bluff top removal violates this mandate.*

### **GOAL 4: Encourage the preservation of the natural environmental resources of the City of Dana Point.**

**Policy 4.1:** Exclude areas designated as Open Space and areas containing wetlands, beaches, and bluffs from the calculation of net acreage available for determining development intensity or density potential.

*COMMENT: The church consultants did not exclude the bluff areas from the net acreage for determining intensity and density.*



**Policy 4.2:** Consider the constraints of natural and man-made hazards in determining the location, type and intensities of new development. (Coastal Act/30240, 30253)

*COMMENT: Rather than considering hazards, the proposed plan exacerbates the hazards by adding a retaining wall over the known landslide area before the geotechnical analysis is conducted or completed.*

**Policy 4.6:** Ensure land uses within designated and proposed scenic corridors are compatible with scenic enhancement and preservation. (Coastal Act/30251)

*COMMENT: The church, its consultants and the Plan ignored the Salt Creek Scenic Corridor.*

#### **DEVELOPMENT OF MONARCH BEACH**

The Monarch Beach area is indicative of development based on master planning efforts and high quality development standards. The Ritz Carlton Resort Hotel and an additional resort hotel site north of Pacific Coast Highway provide focal uses in a community which includes extensive outdoor activities such as golf (The Links at Monarch Beach) and coastal recreation (Salt Creek Beach Park and Dana Strand Beach). Monarch Beach has dramatic public view corridors within the coastal Salt Creek Basin.

*COMMENT: This proposed project is in, and destroys the heart of, the dramatic view corridors within the coastal Salt Creek Basin. The Plan simply and totally ignores this mandate.*

**GOAL 8: Provide for the development of the Monarch Beach area in a manner that enhances the character of the City and encourages the protection of the natural resources of that area.**

**Policy 8.1:** Preserve the opportunity of public view corridors from Monarch Beach area to the coast. (Coastal Act/30251)

*COMMENT: Rather than preserving, this project destroys the view corridor.*

**Policy 8.2:** Assure that adequate public recreational areas and public open space are provided and maintained by the developer as part of a new development. (Coastal Act/30210, 30213, 30240, 30251)

*COMMENT: This has been ignored by the PMP.*

**Policy 8.3:** Assure that the height and scale of new development is compatible with the existing areas.

*COMMENT: The height and scale are totally inconsistent with all of the surrounding areas.*

**Policy 8.9:** Avoid expansion of the golf course or any other land use that occurs at the expense of environmentally sensitive habitat, public park or public areas. (Coastal Act/30210, 30213, 30240)

*COMMENT: Salt Creek, the Salt Creek Trail and the wilderness area are between the church and the golf course. This proposed expansion is prohibited.*

**Policy 8.13:** The existing public trails and public recreational facilities within the Monarch Beach Resort Specific Plan area shall be preserved and maintained. Signs shall be posted at conspicuous locations within the Specific Plan area, and a manned information center established in the Monarch Beach Resort hotel, to inform the general public of the public access and public recreation opportunities available within the Specific Plan area. (Coastal Act/30210-30213, 30220-222, 30223)

*COMMENT: The existing public trail, as with every other element to the east of the project, has been ignored, injured and not mitigated.*

**Policy 8.15:** Preserve, maintain, and where feasible enhance and restore, the riparian habitat, coastal sage scrub habitat, and other environmentally sensitive habitat areas along Salt Creek.

*COMMENT: We urge that the Commissioners walk the Salt Creek Trail from del Avion to PCH before voting. The dust and improperly-controlled runoff will negatively impact the existing wildlife sanctuary adjacent to the church.*

### **Land Use Constraints and Resources**

The Public Safety Element identifies areas of Dana Point subject to such environmental constraints as flooding, landsliding, and seismic conditions. In turn, the Conservation/Open Space Element identifies areas containing important ecological or natural resources. The Circulation and Noise Elements describe roadway/transportation system capacities and areas of the City impacted by noise levels. These constraints, consisting of both natural and man-made factors, influence long-range land use planning and are discussed in detail in the Master Environmental Plan.

*COMMENT: This project exists on a landslide area. The amphitheater effects make the entire Salt Creek Basin noise-sensitive.*

Intensity is most often used to describe non-residential development levels, but, in a broader sense, is used to express overall levels of all development types. The overall intensity of development within the City of Dana Point is lower than the more urbanized areas of Orange County, such as Anaheim, Santa Ana, Irvine and Newport Beach.

*COMMENT: Orange uses a FAR of .4 including garages. Newport Beach's Ordinance:*

### **20.63.060 Building Bulk**

Building bulk shall be calculated to be gross floor area excluding outdoor dining areas and with the

addition of courtyards not open on at least 2 sides. An area which is open to the sky and is open on one side shall be considered to be consistent with this provision.

In addition, for purposes of calculating building bulk, the floor area devoted to portions of a building which span more than 1 floor, such as multi-level lobbies, stairwells, and elevator shafts shall be counted at each floor level. Any level of a building which measures more than 18 feet from finished floor to finished floor level or from finished floor to the average height of the roof above finished floor, shall be considered to occupy 2 floor levels.

Building bulk shall also include the gross square footage of above grade or partially subterranean covered parking areas, except where specifically excluded for a particular location under the Land Use Element of the General Plan.

*Returning to Dana Point:*

For most non-residential development categories (commercial, industrial, office, community facility, and recreation facilities), the measure of intensity known as "floor area ratio" (FAR) provides the most convenient method of describing development levels. Simply stated, the floor area ratio is the relationship of total gross floor area of all buildings on a lot to the total land area of that lot expressed as a ratio.

For purposes of this explanation, both residential density and non-residential intensity are based on the concept of net acreage. Net acreage is assumed to be 80 percent of gross acreage on a City-wide basis and a net acre of land is assumed to equal 35,000 square feet for purposes of calculating density or intensity of land use.

*COMMENT: A glance at the Proposed Master Site Plan, with no calculations whatsoever, shows the intention to overbuild after clearing the ridge top of contours and ancient vegetation. They ignored the largest structure on the property and use full acres, not net acres as mandated by the Plan.*

*The density of this projected will be greater than that allowed in any of the cities that the Dana Point Plan denominates as more dense. They did not honor the Plan.*

## **CONSERVATION AND OPEN SPACE ELEMENT**

The Open Space Element must contain goals and policies concerned with managing all open space areas, including undeveloped lands and outdoor recreation areas. Specifically, the Open Space Element includes open space that is used for the preservation of natural resources, for the managed production of resources, for outdoor recreation, and that which is left undeveloped for public health and safety reasons.

The Recreation/Open Space land use designation encompasses most of the open space that exists in the City including active and passive parkland and natural open space.

### **County of Orange Master Plan of Regional Riding and Hiking Trails**

The County's trails plan provides policies and programs to implement the future development and operation of the Countywide trails system. The Plan includes an inventory of existing and proposed trails and standards and criteria for new trails. The City has incorporated the County's trails criteria into the Conservation and Open Space Element.

## **SCOPE AND CONTENT OF THE ELEMENT**

In addition to the Introduction, the Conservation and Open Space Element includes two sections: Conservation Goals and Policies and Conservation and Open Space Plan. Conservation and Open Space Goals and Policies identify goals and supporting policies addressing open space resources in the City. The Conservation and Open Space Plan is concerned with protecting and enhancing natural and open space resources. The Plan is divided into two sections: Conservation and Open Space. The Conservation Section contains policies for the preservation and utilization of Dana Point's natural resources. The Open Space section focuses on the City's existing and future parkland and the policies for the enhancement and maintenance of its parkland and recreational facilities.

## **CONSERVATION AND OPEN SPACE GOALS AND POLICIES**

A substantial portion of the City's natural open space and biological habitat has been replaced with urban development. However, there are significant portions of the community that remain in a natural state. These areas include the Headlands, portions of Monarch Beach, and the Salt Creek and San Juan Creek Basins. Although portions of these areas are planned to be developed in the future, the conservation of open space and the natural landforms can help to preserve the character of the area. The future development of the areas should respect these natural features of the community. The goals and supporting policies included in this Element address specific issues and opportunities to conserve the City's remaining sensitive lands and to enhance the open space within the City.

*COMMENT: The Salt Creek Basin, one of just four protected domains and site of this project, will be desecrated by the new facilities, wiping out the ancient trees and scarfing away the ridgetop. If the project is scaled back to comply with FAR, the ridge, bluff, cliff and the rest of Salt Creek Basin can be protected. All they have to do is build multi-story buildings on the existing footprint (noting the law of unintended consequences). However, had the consultants paid attention to the east ab initio they would not have the scale, density, contamination, pollution, and destruction problem.*

### **CONSERVATION AND PROTECTION OF WATER RESOURCES**

Although the City of Dana Point has a high percentage of land that has been developed, areas for future revitalization may have a significant effect on the water resources of the community. Therefore, it is essential to protect the existing drainage courses in as natural condition as possible. The depletion or pollution of groundwater resources is a concern. Water conservation measures should be adopted by the City to effectively reclaim water and encourage water conservation throughout the development process.

*COMMENT: As with so many other parts of their analysis, the church and their consultants evaded any realistic evaluation of surface water runoff, ignoring the impacts on Salt Creek, on the wildlife sanctuary, on the golf course, and most especially on the new Salt Creek Water Treatment facility.*

#### **GOAL 1: Conserve and protect surface water, groundwater and imported water resources.**

**Policy 1.1:** Retain, protect and enhance local drainage courses, channels, and creeks in their natural condition, where feasible and desirable, in order to maximize their natural hydrologic functioning so as to minimize adverse impacts from polluted storm water run-off. (Coastal Act/30231)

*COMMENT: Having improperly ignored performing an EIR, the Plan fails to deal with storm water collection, storage, treatment, and discharge. The incomplete "concept" (design and details to be provided in 10+ years after project completion) invites monolithic catastrophic failure, with especially harsh consequences for the houses in Monarch Bay Villas.*

**Policy 1.5:** Retain, maintain, protect, and enhance existing riparian habitat adjacent to drainage courses, channels, and creeks through methods such as, but not limited to, the establishment of buffer areas adjacent to such habitats.  
(Coastal Act/30231)

*COMMENT: Translation – do not build this oversized, excessively dense property on the edge of Salt Creek Basin.*

## **CONSERVATION OF SIGNIFICANT NATURAL FEATURES**

The natural features in the Dana Point area have helped to create the desirable character of the area. Topographical features such as the Headlands, Salt Creek and the San Juan Creek watershed, the bluffs, the inland hills, and the beachfront should be protected from insensitive development. Public views should be conserved and the natural vegetation retained as much as possible. The beach areas and bluff area have potential for excessive erosion if not protected.

*COMMENT: This reiterates that existing property values are preserved by preservation of natural resources. Salt Creek bluffs and inland hills must be protected from insensitive development. Slicing off the top of the ridge/bluff, destroying all of the ancient vegetation, backfilling over a steep canyon wall, and overbuilding to the very edge of the bluff comprise the utmost insensitive development, destroying the desirable character of the area.*

**GOAL 2: Conserve significant topographical features, important watershed areas, resources, soils and beaches.**



**Policy 2.1:** Place restrictions on the development of floodplain areas, beaches, sea cliffs, ecologically sensitive areas and potentially hazardous areas. (Coastal Act/30235, 30236, 30240, 30253)

*COMMENT: The land owner of the property immediately north of the project declined to rebuild after losing an apartment building to a landslide. The church wants to build a retaining wall to hold their backfill on top of the fault, then perform the necessary geologic work ten years down the road. The Commission should order an EIR and completion of all geologic/geotechnical/hydrologic evaluations before any resubmission.*

**Policy 2.2:** Site and architectural design shall respond to the natural landform whenever possible to minimize grading and visual impact. (Coastal Act/30250)

*COMMENT: The church proposes destruction of the natural landform with maximum grading and unbelievable negative visual impact throughout the Salt Creek Scenic Corridor. The church proposes removing and shuffling 100,000 cubic yards of dirt around the site for ten years. Parts of the site will be excavated as deep as 30+ feet to hide the inadequate cisterns and protect the 50 MPH view from Crown Valley Parkway.*

**Policy 2.3:** Control erosion during and following construction through proper grading techniques, vegetation replanting, and the installation of proper drainage, and erosion control improvements. (Coastal Act/30243)

*COMMENT: This mandate has been ignored.*

**Policy 2.4:** Require the practice of proper soil management techniques to reduce erosion, sedimentation, and other soil related problems. (Coastal Act/30243)

**Policy 2.7:** Require geotechnical studies for developments that are proposed for steep slopes (4:1 or steeper), on or adjacent to coastal or inland blufftops, and where geological instability may be suspected. (Coastal Act/30253)

*COMMENT: The geotechnical studies are deferred until the church gets more money (or runs out of money). Under this Policy, the project should be stopped dead. We have a steep slope, known hydrogeology problems (see the former theater in the Gelson's shopping Center), known landslide problems immediately to the north of the proposed retaining wall, and steep slopes to be covered and backfilled. A properly sized project would not require any of these violations.*

**Policy 2.8:** Minimize risks to life and property, and preserve the natural environment, by siting and clustering new development away from areas which have physical constraints associated with steep topography and unstable slopes; and where such areas are designated as Recreation/Open Space or include bluffs, beaches, or wetlands, exclude such areas from the calculation of net acreage available for determining development intensity or density potential. (Coastal Act/30233, 30253)

*COMMENT: A mandate ignored. The church must site and cluster away from steep topography, unstable slopes and recreation/open areas, all of which this PMP ignores. Furthermore, the PMP includes all of these prohibited site conditions in their determination of development intensity and density potential. Instead they propose cutting the top off, siting and clustering everything, including the screaming kiddies, at the very top of the steep topography (actually beyond) on top of the backfill behind a 25-foot (plus foundations) monolithic retaining wall over a known landslide area. And with the audacity usually only found in Washington, include all of those unstable areas in their miscalculation of FAR.*

**Policy 2.9:** Preserve significant natural features as part of new development. Permitted development shall be sited and designed to minimize the alteration of natural landforms.

Improvements adjacent to beaches shall protect existing natural features and be carefully integrated with landforms. (Coastal Act/30240, 30250, 30251)

*COMMENT: Because from the beginning the church consultants saw no need to look or mitigate to the east, the PMP has maximized the alteration of land forms. The project could have a desirable fluidity if sized within FAR and built above the existing contours. As designed, it's too big and too ugly.*

**Policy 2.10:** Adopt setback standards which include, at a minimum, a 25 foot setback from the bluff edge or which take into consideration fifty years of bluff erosion, whichever is most restrictive for a particular blufftop site. When necessary, require additional setbacks of buildings and site improvements from bluff faces which will maximize public and structural safety, consistent with detailed site-specific geotechnical report recommendations. (Coastal Act/30253)

*COMMENT: The church ignores the 25-foot setback and has not completed the requisite detailed site-specific geotechnical report. How can you let them graduate when they have barely started their homework?*

**Policy 2.11:** Preserve Dana Point's bluffs as a natural and scenic resource and avoid risk to life and property through responsible and sensitive bluff top development, including, but not limited to, the provision of drainage which directs runoff away from the bluff edge and towards the street, where feasible, and restricting irrigation and use of water-intensive landscaping within the setback area to prevent bluff erosion. (Coastal Act/30251, 30253)

*COMMENT: Where responsibility has been mandated, the church consultants act cavalierly and irresponsibly by building to the edge of the bluff and beyond with all runoff improperly discharged without treatment into the Salt Creek Scenic Corridor.*

**Policy 2.12:** New bluff top development shall minimize risks to life and property in geologically sensitive areas and be designed and located so as to ensure geological stability and structural integrity. Such development shall have no detrimental affect, either on-site or off-site, on erosion or geologic stability, and shall be designed so as not to require the construction of protective devices that would substantially alter natural landforms along bluffs and cliffs. (Coastal Act/30253)

*COMMENT: The plan for the entire eastern perimeter of the project violates the law. The project has been designed to significantly and negatively alter the natural landforms along the Salt Creek Bluffs and Scenic Corridor.*

**Policy 2.13:** Bluff repair and erosion control measures such as retaining walls and other similar devices shall be limited to those necessary to protect existing structures in danger from erosion to minimize risks to life and property and shall avoid causing significant alteration to the natural character of the bluffs. (Coastal Act/30251, 30253)

*COMMENT: No retaining walls for new construction. Had the consultants looked to the east they could have avoided these violations. Again the plan severely alters the natural character of the bluffs in the Salt Creek Scenic Corridor.*

Although there are limited quantities of undisturbed vegetation several sensitive species have been observed with the City including the California Black Tailed Gnatcatcher, the Monarch Butterfly, and the Turkish Ruggish (plant).

*COMMENT: All of these species of concern are in the wildlife sanctuary between the church and the golf course. A half inch of extra rain could wash all of the endanger flora and fauna into the Pacific.*

**GOAL 3: Conserve significant natural plant and animal communities.**

**Policy 3.1:** Environmentally sensitive habitat areas, including important plant communities, wildlife habitats, marine refuge areas, riparian areas, wildlife movement corridors, wetlands, and significant tree stands, such as those generally depicted on Figure COS-1, shall be preserved. Development in areas adjacent to environmentally sensitive habitat areas shall be sited and designed to prevent impacts which would significantly degrade those areas through such methods as, the practice of creative site planning, revegetation, and open space easement/dedications, and shall be compatible with the continuance of those habitat areas. A definitive determination of the existence of environmentally sensitive habitat areas on a specific site shall be made through the coastal development permitting process. (Coastal Act/30230, 30240)

*COMMENT: Had the consultants looked to the east, had they read the Dana Point and Monarch Beach Plans and had they performed an EIR, they could have had a chance of complying with this mandate. As well as real potential for damage to important plant communities, wildlife habitats, marine refuge areas, riparian areas, wildlife movement corridors, wetlands, the project will destroy the most significant natural tree stands in the Salt Creek Basin and the Salt Creek View Corridor.*

**Policy 3.8:** Development in areas adjacent to parks and recreation areas shall be sited and designed to prevent impacts which would significantly degrade those areas through, among other methods, creative site planning and minimizing visual impacts, and shall be compatible with the continuance of those parks and recreation areas. (Coastal Act 30240)

*COMMENT: By not looking to the east, the consultants allow the significant degradation ecologically and visually to the golf course, to Salt Creek, the Salt Creek Trail and the Salt Creek Scenic Corridor.*

## **PRESERVATION OF NATURAL RESOURCES AS OPEN SPACE AREAS**

The City of Dana Point recognizes the importance of conserving natural resources by preserving open space throughout the community. The City will encourage sensitive planning of its remaining open space lands to provide an appropriate transition between urban uses and open space. By designating open space in key locations significant views and public access to the ocean and harbor can be provided.

*COMMENT: Instead of providing a transition, the PMP uses a nonconforming retaining wall to extend its destruction beyond the edge of the open space, and then overbuilds on the space. If properly designed, the project would be constructed entirely within the existing footprint.*

### **GOAL 6: Encourage open space areas to preserve natural resources.**

**Policy 6.1:** Mitigate the impacts of development on sensitive lands such as, but not limited to, steep slopes, wetlands, cultural resources, and environmentally sensitive habitat areas through the development review process. (Coastal Act/30233, 30240, 30244, 30253)

*COMMENT: The plan ignores the steep slopes and the environmentally sensitive habitat.*

**Policy 6.5:** Preserve and protect open space, steep slopes, cultural resources, and environmentally sensitive habitat areas through open space deed restrictions, dedication, or other similar means as a part of the development and subdivision review process. (Coastal Act/30250)

*COMMENT: The PMP ignores the steep slopes.*

**Policy 6.6:** Concentrate higher intensity uses in areas containing less sensitive landforms and preserve the most sensitive landforms and natural resources as open space.

*COMMENT: If the project must as large as suggested, build it where there is room for it off site at another location.*

### **CONSERVATION/OPEN SPACE FOR THE PRESERVATION OF NATURAL RESOURCES**

The most significant natural resources in Dana Point include the Pacific Ocean, land with open space potential, lands with significant biological resources, water resources, significant landforms, and those sites or structures which have historical, archaeological or paleontological significance. The Headlands is the largest remaining undeveloped area within the City. This area contains coastal sage scrub vegetation which supports a variety of animal species. The Pacific Ocean and shoreline provides important marine habitats for many species. Certain sections of the City's coast have been designated by the California Department of Fish and Game as three separate but contiguous marine life refuges. The other area of natural resource open space includes San Juan Creek and Salt Creek and the beaches and bluff areas along the coast.

These important natural resource areas are shown on Figure COS-1. Other areas of natural resource open space include San Juan Creek and Salt Creek and the beaches and bluff areas along the coast.

*COMMENT: No matter how one completes the analysis, the Salt Creek Basin is important to Dana Point. That fact alone mandates findings of potentially significant impacts and the performance of an EIR. The Planning Commission should direct the applicant to comply with Dana Point FAR and conduct a complete EIR, paying particular attention to every aspect of the Salt Creek Scenic Corridor.*

## **CONSERVATION AND OPEN SPACE FOR PUBLIC HEALTH AND SAFETY**

These areas include the floodplain zones along the San Juan Creek and Salt Creek as well as along the coastal areas.

*COMMENT: Salt Creek cannot be ignored. The PMP ignores all aspects of Salt Creek.*

## **CONSERVATION MEASURES**

To protect and conserve sensitive lands that occur within the City, the following measures will be utilized:

° Excavation or grading shall not be permitted unless site specific geologic/soils study indicates no safety problems will result from such grading.

*COMMENT: The church has not completed the mandated geologic/soils testing. The project should stop until completion of the testing.*

Archaeological and biological surveys shall be required for any development projects on lands identified in this Element as potentially paleontologically, historically or biologically sensitive. Mitigation measures shall be developed and implemented to mitigate any significant impacts.

## **THE OPEN SPACE PLAN**

### **Recreation/Open Space**

The Recreation/Open Space designation includes both public and private recreational uses necessary to meet the active and passive recreational needs of area residents and visitors.

Recreational activities include golf courses/driving ranges, community recreational facilities, public parklands and indoor and outdoor sports/athletic facilities. Recreation uses include



museums, galleries, outdoor theater, designated open space and similar uses.

### **Scenic Resources**

The scenic resources in Dana Point are a major asset of the community. In the western portion of the City, including Monarch Beach, high points provide sweeping views of the southern California coast and Catalina Island while the lower elevations provide whitewater views of the shoreline.

### **NOISE ELEMENT**

*COMMENT: The Noise Element was commented on extensively in our original comments filed in May. The Dana Point Plan Noise Element was not adequately and completely addressed by the PMP. The noise element considerations were not applied to the east.*

### **URBAN DESIGN ELEMENT**

#### **Monarch Beach**

Monarch Beach has a dramatic setting focused on the Pacific Ocean and Salt Creek Basin. The area has benefitted by master planning and more current development standards. Salt Creek Beach Park, Dana Strand Beach and The Links at Monarch Beach give the community an outdoor recreation emphasis. The most prominent landmark is the Ritz Carlton Resort Hotel, soon to be accompanied by the Monarch Beach Resort. Monarch Beach has few Urban Design issues due to its newness and quality of recent planning efforts. Planned Urban Design improvements are:

- ° Completion of the Salt Creek regional trail from Laguna Niguel to Salt Creek Beach. Construction of a public beach building at Salt Creek Beach.
- ° Stronger development standards that provide carefully-sited

and designed projects that fit the existing topography,  
minimizing mass-grading and large engineered flat pads.

*FINAL COMMENT: MAINTAIN THE EXISTING TOPOGRAPHY. MINIMIZE MASS GRADING. AVOID LARGE FLAT PADS. The final big three are all violated by the PMP. The Salt Creek basin should not have been ignored. The proposed project is too big for the site, violating FAR standards. An EIR must be performed. Each of the Plan conditions, standards, policies and suggestions, many of which are addressed herein, must be addressed in any resubmission. The application must be rejected as incomplete.*

7/16/2009 10:26 AM  
Robert F. Saint-Aubin  
Deanna D. Saint-Aubin  
Monarch Beach, CA

Copyright rfs 7-2009

# SAINT-AUBIN MEDIATION

---

ROBERT F. SAINT-AUBIN  
MEDIATOR ◊ ARBITRATOR ◊ ATTORNEY  
53 CASSIS ◊ MONARCH BEACH ◊ CA ◊ 92629  
949-466-2400 ◊ FAX 949-496-5075  
RFSAINTE@SLOAN.MIT.EDU

May 22, 2009

Ms. Erica H. Demkowicz, AICP, Senior Planner  
City of Dana Point, Community Development Department  
33282 Golden Lantern  
Dana Point, CA 92629

**Re: SOUTH SHORES CHURCH MASTER PLAN**

Dear Ms. Demkowicz:

I attach hereto my comments in opposition to the South Shores Church Master Plan, followed by a picture of the existing church and canyon/valley slope taken with a normal focal length lens from our bedroom and then annotated excerpts from the South Shores Church Master Plan.

As you will see from reading my comments, the proposed non-church addition will have a major negative impact on us and our neighbors, significantly diminishing our quality of life, environment and property values.

We respectfully request, that in view of the failure of the South Shores Church Master Plan to acknowledge our existence, less than 1000 feet away, that the plan be rejected in its entirety and the project quashed.

I will be happy to answer any of your questions. I request that I be notified of all hearings and that I and my neighbors be given adequate time to comment at the hearings. Finally, if you or any of your colleagues desire to observe the situation from the east, you are welcome to do an onsite inspection from here.

Very truly yours,

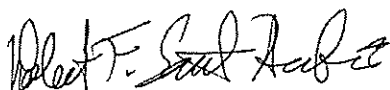

WWW.COASTMEDIATOR.COM  
ADMITTED IN CALIFORNIA AND NEVADA

SAINT-AUBIN  
5/22

5/22/2009 1:41:15 PM

I reside at 53 Cassis, Monarch Beach, CA in Corniche Sur Mer, a community of 192 homes. I am a California attorney and mediator. I am an MIT graduate and devoted most of my career to solving environmental problems in the chemical and mining industry. I understand environmental considerations and the impact of excavation and dust on neighborhoods. I will start my comments by saying that in the furthest corner of the Nevada desert, a mining company would not be allowed to have the impact on the naked desert that this proposed project will have on its neighbors to the east. Although submitting these comments on my own behalf, I am Secretary of the Corniche Sur Mer Homeowners Association. Our community is located less than 1000 feet directly to the east of the proposed project, separated only by two fairways of the Monarch Beach Golf Links.

I am presenting these comments in opposition to the Proposed Master Plan for the South Shores Church (PMP) dated April 2009.

Although Corniche Sur Mer is the closest neighbor to the east side of the Church project, neither the Church nor the city gave any consideration whatsoever to us. Until this report to the Homeowner's Association, we were given neither notice of the project nor opportunity to comment. The report falsely asserts that neighboring residential communities were solicited for comment and input. This community was excluded from such neighborly communications.

The pictures used in the report were taken with wide angle lenses and from carefully selected irrelevant viewing angles, artfully but artificially reducing the visual impacts of the project. The pictures increase the apparent distance from the project and suggest, as does the entire report, that the project has no impact on the taxpaying properties to the east. The one view from the east was taken from the St. Regis, which is twice as far from the project as is Corniche and at an acute angle that virtually obscures the project. The drawing showing the eastern aspect has also been greatly shortened vertically and lengthened horizontally to give the erroneous impression that the project merely skims the top of the hill rather than consuming half of the hillside.

The noise and dust from the earlier soils/geotechnic project totally disrupted our lawful, peaceful enjoyment of this tranquil space. Ordinarily, our noise is measured by the sounds of the waves at Salt Creek Beach, not the roar of traffic on Crown Valley, the standard suggested by the report. The PMP proposes to mitigate views and noise in the other three directions, thereby directing all the adverse impacts of their project to Corniche.

Unfortunately, the configuration of the valley serves to attenuate both sound and dust, first from the project, and then from the sunrise to 10 pm "activities." As we are directly across the valley from the Church, noise and visual pollution sail unimpeded directly from the Church into our bedrooms, living rooms and kitchens.

As an attorney and mediator, I am a professional working from my home, as are many of the other residents of Corniche. For the duration of the project, the dust and noise will make using our offices unbearable. You cannot conduct a telephone conference directly across from a belching, blinging, beep-beep-bleep fleet of unmuffled diesel earth movers. Our entire community will be compelled to turn on the air conditioning and close the windows, cutting us off from the delightful ocean breezes that originally brought us to Monarch Beach and Dana Point. Also, my wife and I, like many others, suffer

from severe allergic and asthmatic reactions to dirt and dust. Essentially our prized outdoor living will terminate for the duration of the project.

During the previous shrill, peace- and tranquility-destroying geotechnical "study" conducted by the Church, one of our neighbors contacted Dana Point and the Church. They were assured that the Church would never obtain funding to complete the project, and besides, the entire project would be below grade. Unless funding is in place in advance, there is no assurance the project will be finished once they desecrate the hillside.

The report repeatedly asserts that the Church mitigated each of the concerns by putting the principal parts of the structures below grade. It repeatedly states that the elevation from the west, from the north and from the south is one story above grade and one story below grade. Although the impact to the west, north and south have been mitigated by creation of a single story project, to achieve this falsity of total mitigation, the report shows as many as five stories (see Ex 2-7) facing the east, directly across the open valley from us. In every instance in which the Church claims mitigation in the report, they very conveniently ignore the view from the east, which is most impacted. It turns out that if the project is "below grade" that means that it is kept below the grade of Crown Valley by cutting and filling into our view corridor. Because they dig into the slope and step the buildings, we face not a one story building but stacked three- to five-story structures. Exhibit 2-3 (lower level/hillside) misrepresents the façade by using different horizontal and vertical scales to diminish the apparent impact of the project. It also places the entire structure on one level rather than the multiple levels required by the existing ridge contours. The plans also fail to show any landscaping mitigation in our direction.

Being directly across the canyon from the project means we will see every inch of the cut, fill, construction and resulting mass of new buildings, unlike the neighbors on the other three sides. Yet we were not consulted. We are the only view that faces the *entire* project, two non-subterranean stories upon two + non-subterranean stories. Each of the new buildings will be fully visible in its entirety from across the canyon. The construction, excavation, compacting and subterranean support for the project will totally denude the valley wall.

Just north of the project a large gap remains from the last unmitigated earth slide. If the church rebuilds the hill in the same manner as the Pointe Monarch project to the south, dust and construction noise will make this community uninhabitable for the duration of the project.

Another consideration is how much water will we be compelled to consume to remove project-created dust? In a time of severe water shortage and restricted private use, the Church makes no evaluation of the tremendous amount of water to be consumed/wasted by the necessary dust suppression. What will be the impact on Salt Creek, Salt Creek Beach and the new surface water runoff treatment plant?

The report also gives no evaluation of increased lighting shining into our bedroom windows.

The report makes much about the historical use of the site as a church. We have no objection to the picturesque country church across the golf course from us. The "church" instead is building a tax exempt wedding-community-convention center to unfairly compete with the taxpaying resort properties in the community. The proponents acknowledge that they will use the facilities for rental purposes, open to all takers, effectively having no control over noise generated by their tenants.

## **TURNING TO THE PROPOSED MASTER PLAN:**

Page 1-1. Introduction notes “potentially significant environmental impacts.” The report pays no attention whatsoever to *any* of the impacts viewed and suffered from the east.

Page 2-1. The PMP makes no mention of the existing 192 residential properties at Corniche sur Mer, directly across the canyon and less than 1000 feet from the project. A preschool, community life center and fellowship hall/gymnasium will increase the noise impact across the canyon.

Page 2-2. The project adds 46,817 square feet of non-church use. The PMP consistently misrepresents the project as “below grade – in fact, from the east looking west, no part of the project is below grade. The PMP suggests a maximum height of 31 feet, ignoring that multiple buildings are separately stacked so that the impact looking west is more like a five-story building. See cross-section Exhibit 2-7 looking north, which clearly shows a five-story profile from the first floor to the parapet.

Noise generating “activities will take place from sunrise to at least 10 pm. Those of us who work from home will have the use of our homes severely restricted.

Page 2.5. Although shown on the map directly across from the project, no consideration was given to the excessive impacts on the Corniche community owners.

Page 2-11. The project will be in use for evening and weekend functions, thereby generating unacceptable peace-disturbing noise at times when all Corniche residents will be at home. We will have no peace.

Community Center Life destroys our quality of life. To the north, south and west the Church buries most of the new structures below grade. All of the structures from the east, facing west, will be above cuts into the existing grade. The entire facility will be in operation continuously from early morning to late evening, including nights and weekends. The report acknowledges a litany of noise-generating activities with no mitigation to the east. The report reiterates the hours of impact.

Page 2-12. The PMP starts the page ignoring the impacts to the east, while proudly proclaiming the mitigation in the other three directions, and emphasizing the expanded facilities will be operated, in fact to the detriment of everyone that will be compelled to listen to them. It states: “. . . will also provide for weekday and evening mid-week opportunities.”

Again the Christian Education building is below grade – except on the important, ignored east side. And the facilities will be available for multiple non-church purposes to all comers around the clock.

Page 2-14. The project will take place in multiple phases, increasing the harassment and dust from the demolition and construction phases essentially in perpetuity.

Page 2-17. Exhibit 2-3 graphically depicts a three- to five-story panoramic building (made up of multiple overlapping units) directly across from the bedrooms of half the properties in Corniche Sur Mer. The Exhibit uses different horizontal and vertical scales, misrepresenting the resulting impact. The Exhibit places the south structure on the same elevation as the sanctuary. Even with their proposed massive cut

and fill the depiction is an impossibility unless the existing ridge contour is totally removed. The PMP proposes no landscape screening and no mitigation for construction noise or demolition and construction dust.

Page 2-23. Exhibit 2-6 belies the oft-repeated assertion that the PMP mitigates by having two-story buildings with one story below grade. From the east, looking west, it's a series of stacked, overlapping multiple stories that add up to four or five stories total, all fully seen in entirety from across the canyon, less than 1000 feet away, WITH NO MITIGATION. From the east looking west, none of the buildings are below grade.

Page 2-25. Exhibit 2-7, extolling the virtue of the parking structure being below grade, once again clearly shows that the PMP intentionally ignored those of us to the east.

Page 2-35. We have no objection to the use of the property for a church. The proposed project is a commercial tax-exempt facility directly competing with taxpaying properties in the neighborhood.

The church held no community meetings with this community. Until the PMP was issued, we received no notice of the proposed project (other than the unacceptable noise and dust caused by what we now know was the geotechnical evaluation).

Page 3-1 Analysis. The project should be rejected simply on the opening line of this section: "The proposed project will not result in any significant environmental impacts to aesthetics." However measured, the assertion is baldly false. The authors and their collaborators gave no consideration at all to their neighbors to the east less than 1,000 feet across open air from the project. All of the noise, dust and light from the demolition, construction and use of the proposed project will adversely and significantly impact the aesthetics of our community. An open construction zone stretched out for a decade or longer will diminish the marketability of our property and destroy our quality of life, from sun-up until the last screaming teenager retires. The whole thesis of the opening paragraph (actually the whole thesis of the report) is that the project has no impact because it is mostly below grade. To us looking from the east to the west, none of the project is below grade. None of the project is screened by landscaping. The canyon wall which will be desecrated by cut and fill is a scenic view and a scenic resource from the east side of the canyon and golf course.

Exhibit 2-3 defies the assertion that the proponents have avoided excessive massing. They have created a visual monolith with stacked overlapping cumulative buildings, not the streamlined simplicity depicted. The second paragraph in its entirety asserts the masterful application of below grade design to avoid aesthetic impacts to the north, south and west. Conveniently, once again the PMP makes no mention of the impacts to the east. All the accomplishments from the north, south and west should have been considered from the perspective of the east as well. Because of the thousand-foot, clear air line-of-sight openness, the visual impact of each element is greater from the east than from the north, south or west.

Page 3-2. They worked to ensure that visual impacts were avoided or minimized, while ignoring that they were increasing the impacts from the east. They acknowledge that without mitigation there will be significant adverse impacts from the preschool, from play areas, and from dust and noise.

Because of its location on the Crown Valley side of the property, perhaps the parking garage will have minimal impact despite its two stories above grade, unless of course their cut and fill sends clouds of particulate and noisy diesel sounds across the canyon.

Page 3-3. The Church did some photo simulations, but none directly from the east, the most materially affected community. The simulations distort distance and impact by the selective use of wide angle lenses and acute angles that provide screening by intervening trees to the south on the hillside, trees that provide no protection of mitigation to the east.

They are incorrect in their assertion that the view will not be different from the existing one. They have added almost 50,000 square feet of buildings with accompanying continuous, multi-story facades.

It is obvious from the paragraph about Exhibit 3-3 that their intent was to sacrifice our aesthetics and community to preserve their views of the golf course and ocean.

Exhibits 3-4 and 3-5 demonstrate that to ignore Corniche, the Church went significantly south of the project to take an angled view from the St. Regis, minimizing the apparent impact, while ignoring those of us actually negatively impacted and who are less than half the distance from the project. Their inclusion only of the St. Regis views improperly suggest that the St. Regis is the only neighbor to the east.

Yes, the existing quaint church is pleasantly visible. An additional 50,000 feet of commercial space does not continue the character of the neighborhood or of their use. That a wide range of public and private uses may be allowed is not justification for incorporating all of those uses in a new, expanded tax-exempt facility on a single site.

Page 3-4. Once again, they assert they are good and righteous because they are proposing to build below grade. From the east none of the construction is below grade. No landscaping is proposed for the eastern boundary of the project.

They assert that Salt Creek and the golf course are scenic areas but that the property on the canyon wall they propose to desecrate is not a scenic area. From the east the property on the canyon wall to be desecrated is a fundamental part of the scenic view.

The redevelopment is not a redevelopment as that term is commonly understood; it is a significant expansion of both the existing disturbed area and an increase of the project footprint. In addition, if they are to complete necessary slope stabilization, they will disturb additional natural areas.

Page 3-17. Construction activities will make our properties uninhabitable for the duration because of dust and noise.

No landscaping is provided between the project and the golf course.

The construction activity will have a severe, significant impact on those of us residing across the canyon. A multiphase project of a minimum of 250 days, which could occur over as long as 10 years, will not be minimal – it's more like a major portion of our remaining life expectancy.



An ear drum-destroying cacophony of beeping bleeping diesel haul equipment, excavators, compactors and trucks are typical of construction projects involving the movement of hundreds of thousands of yards of earth. The Church proposes to put that in our front yard with no mitigation.

Page 3-18. Lighting will be shining into our bedrooms, just like at a Las Vegas hotel.

Page 3-21. Doing the necessary cut and fill and compacting to overcome the landslide risk will, even with spraying, generate dust that, as happened with the Monarch Pointe Project much further to the south, keep us from living with open windows and doors for the duration of the project, plus wasting enormous quantities of water to wash away their dust. Anyone with allergies or asthma might as well move out.

Page 3-24. Reducing dust by 50 percent is effectively the same as not reducing dust at all. As a professional operating from a home office, I will not be able to work for the duration of the project.

Page 3-26. Much has been said recently about compelling the residents of Dana Point to reduce their water usage. A lot more water could be saved by not allowing this wasteful, bad project.

Page 3-30. The PMP evaluation does not consider the nuisance dust and noise impact on those most affected – those of us downwind and unprotected by any intermediate barriers.

They mitigated the adverse impact on Corniche sur Mer by edicting us out of existence. If we do not exist, we cannot be impacted.

Page 3-39. The report does not adequately address the land slide potentiality, especially considering the still visual remnants of the apartment slide a bit north of the Church but adjacent to the Church property.

Page 3-40. Five stages, 101,359 cubic yards of dirt moved multiple times less than 1,000 feet away. How can they assert no impact?

Page 3-41. The land area is unstable. It is unsuitable for such a massive project. The more mitigation done on site to avoid the impacts of earth slides, the more dust and noise interfering with our peaceful enjoyment of our community. It will take decades for the vegetation to regenerate on the denuded slope.

Page 3-61. We do not accept the thesis that larger facilities are improved facilities. In fact the report repeatedly asserts that the heart of a church – the sanctuary – will not be modified by this attempt at building a tax-exempt industrial facility under the guise of an existing legitimate church.

The new project is not a church. It's a tax-exempt meeting-party-reception facility in direct competition with taxpaying properties like the St. Regis, Salt Creek Grill, the Marriott and the Ritz Carlton.

From the east the parking garage is not below grade; nor is any other part of the facility below grade. Contrary to the assertion, nothing was done to reduce actual impacts of air quality, noise and aesthetics.

They can only assert that there will be no significant impact relative to land use by continuing to ignore the 192 residences directly to the east.

Page 3-65. The project will increase noise levels more than 18 hours a day seven days a week after completion of construction, which may take as long as 10 years and will take one year if conducted continuously.

At our residential property lines there will be unnecessary, nonpreexisting, excessive and annoying sounds from demolition activities, from cut and fill, from diesel vehicles, from OSHA-mandated beep beep as construction vehicles move back and forth, from compacting and from construction. This will be followed by raucous parties, teenagers and children at all hours of the day and night, all directly across from our bedrooms. Nothing has been proposed to mitigate noise, let alone to bring it to acceptable levels. Simply they say "no problem" because they deny our existence.

Page 3-67. We do not now suffer from Crown Valley noise levels. With commencement of this project, we will be subjected to higher noise levels than if we were on Crown Valley. The sound of the breaking waves, which we now enjoy, will be destroyed. But they made no analysis of the impact of the noise levels on our community because they intentionally ignored our community in every aspect of their planning.

A few of our neighbors had informal cognizance of the planned project and were assured by the Planning Department that there was nothing to worry about because the entire addition would be below grade. Well, none of the project from the east is below grade.

Page 3-68. None of the noise tests were performed on the east side of the project where, by the design, all of the noise is directed. Playgrounds, teen age parties and wedding receptions generate more unpleasant noise than traffic. Construction vehicles will prevent our conducting telephone business from our houses.

Page 3-69. The Life Center will be operated at least from 7 am to 10 pm, seven days a week. For us, no relief forever. The cut and fill, soil compaction and construction will take place for at least 250 work days or a minimum of one year.

Page 3-71. They will build it and then argue they must have their permit because it's already built. They will say they did not think it was going to be that noisy. Presumptively, the same consultants and engineers who ignored the east will conduct the final studies, again ignoring all impacts on the east. This attitude that permeates the entire report mandates that the entire project be rejected.

There is absolutely no question that there will be a permanently unacceptable increase in ambient noise levels in the project vicinity.

Page 3-72. Instead of making all the noise at once, they pat themselves on the back for stretching it out over five phases. They do acknowledge that construction noise will be loud. They ignore the attenuation and echoing effect of sending noise across a canyon. The Pointe Monarch cut and fill project was more than twice as far away. The diesel and beep beep bleep made conduct of telephone calls impossible, even with the windows closed.

When there is no preexisting noise, any disruptive noise is significant. We enjoy no noise now. Our property value is based upon the pastoral effect of the canyon and golf course with a small picturesque church atop the ridge framed by the setting sun, a view the project will destroy.

Page 3-73. They will move over 100,000 cubic yards of material multiple times. Their arithmetic is incorrect. They posit at least 52 days per phase, five phases equals 260 days. If they work five-day weeks, that's one year, not 5 to 6 months. And they are going to stretch the phases out over a long time.

Existing traffic on Crown Valley may be louder on Crown Valley, but not here. Crown Valley is not cut into the hillside directly across from us as is this proposed project.

Page 3-77. Here they finally admit that they are significantly increasing the uses and types of uses of the property. It seems that since no one objected to a small picturesque church 50 years ago, they now have a license to build a Las Vegas strip facility across from our bedrooms.

Page 3-79. Significantly more police will have to be added to respond to all of the disturbing the peace, noise and dust complaints they will generate.

Page 3-81. Outdoor playground areas generate excessive noise throughout the day.

Page 3-94. In these days of curtailed domestic and commercial water usage, the current occupants propose a multiphase, multiyear excessive watering project that makes no sense. They do not mention the impact of their construction run-off on Salt Creek, the golf course and the new run-off water treatment plant to the south of the project.

Page 3-98. They say they have identified several significant impacts. By ignoring the east totally, they see no need for mitigating any of the impacts. For that reason the project should be rejected in its entirety.

Appendix A – Checklist 3. If the authors, planners, promoters, and collaborators had the ability to exhibit any intellectual honesty, they would have checked off Significant Adverse Impacts for Aesthetics, Land Use Planning, Air Quality, Noise, Mandatory Findings of Significance, Geology and Soils and Recreation.

Appendix A – Checklist 4. Again, the report is inaccurate, and the conclusions false. I note that the report is unsigned. A Google search for Cheryle L. Hodge produces a resume of a planner, showing neither professional certifications, nor any degrees in relevant disciplines. The incompleteness of the report supports a conclusion that while experienced, the author is professionally unqualified.

Appendix A -- Checklist 6. They want the project, so they say everything is ok, having ignored the real impacts.

Appendix A – Checklist 7. They do not adequately address the earth slide potential.

Appendix A – Checklist 8. The project sets the conditions for another landslide.

Appendix A – Checklist 10. The project is improper under land use planning and for its noise impacts to the east.

Appendix A – Checklist 11. The project will increase the burden on the police.

Appendix A – Checklist 12. The project will have cumulative as well as individual significant impacts ignored throughout the report. The project will have environmental effects which will cause substantial adverse effects on human beings, directly and indirectly.

Regretfully, if Dana Point allows this project to proceed, we will have to test the omissions, errors, lack of credentials and ridiculous theories of mitigation in a court of law where we can call witnesses and cross-examine so-called experts.

Robert F. Saint-Aubin  
Deanna D. Saint-Aubin  
53 Cassis  
Monarch Beach, CA 92629



SAINT-AUBIN  
5/22

# City of Dana Point

Initial Study/Mitigated Negative Declaration



*South Shores*  
CHURCH

Proposed Master Plan

April 2009

## 1. Introduction

The City of Dana Point (hereinafter "City") has prepared this Initial Study and Mitigated Negative Declaration (MND) to evaluate the potentially significant environmental impacts that could occur from the proposed construction and operation of the South Shores Church Master Plan project (hereinafter referred to as the "project"). This introductory section briefly describes the agency use of the document and related studies. A detailed project description is presented in Section 2 of this document.

Pursuant to §15367 of the California Environmental Quality Act (CEQA) Guidelines, the City of Dana Point is the Lead Agency responsible for preparing this Initial Study and Mitigated Negative Declaration to address the potential impacts associated with the proposed project.

### 1.1 Incorporation by Reference

Certain documents are incorporated by reference into this environmental document pursuant to CEQA Guidelines §15150. Where a document is referenced, its pertinent sections have been briefly summarized in the discussions in this environmental document. These documents are also identified on page 14 of the Environmental Checklist presented in Appendix A and Appendix B of this environmental document.

### 1.2 Responsible Agencies and Agencies Consulted

Responsible agencies include all public agencies other, than the Lead Agency, which have discretionary approval power over the project (CEQA Guidelines §15381). Responsible agencies in respect to this project may include:

- California Regional Water Quality Control Board (CRWQCB)
- Orange County Fire Authority

Public Agencies consulted include the California Coastal Commission, the County of Orange, the Orange County Transportation Authority (OCTA), the Orange County Sheriff-Coroner, and the adjacent cities of Laguna Niguel, Laguna Beach, and San Juan Capistrano. Other agencies expected to be involved in the project include public utility and service providers (i.e., gas, electric, water, wastewater, solid waste, public transportation).

### 1.3 Environmental Process and Agency Use of Document

This environmental document has been prepared consistent with the California Environmental Quality Act (CEQA) of 1970 (*Public Resources Code*, §21000-21177) and the CEQA Guidelines. This environmental document is used as a decision-making tool by the City of Dana Point in

## 2. Project Description

### 2.1 Project Description

The Project Description for this environmental document provides an understanding of all components of the project. The following sections describe the project location, surrounding site uses, and existing site characteristics, as well as project details.

#### 2.1.1. Project Location and Boundaries

The project site encompasses approximately six acres and is located at 32712 Crown Valley Parkway in the City of Dana Point in the southern portion of Orange County, California. The property is located on the east side of Crown Valley Parkway across from the intersection of Crown Valley Parkway and Sea Island Drive. The Regional Map is shown in Exhibit 2-1 and the Vicinity Map is shown in Exhibit 2-2.

#### 2.1.2. Existing Site Characteristics

The six-acre site has been previously graded and is developed with several buildings, including a sanctuary, chapel, administration and fellowship hall and preschool totaling 42,545 square feet, which comprise the South Shores Church. The existing site plan is illustrated on Exhibit 2-3. The subject property is relatively level in grade from that portion closest to Crown Valley Parkway and then proceeds to slope downward in a southeast direction towards the Salt Creek trail and golf course. The uses adjacent to the site include residential uses located directly south and to the west of the project site across Crown Valley Parkway. Residential uses are also located approximately 175 feet to the north of the project site, approximately 70 feet below the elevation of the subject property. There is an open space slope area located to the east with a golf course beyond. Properties to the south are designated Residential Multiple Family (RMF 14) on the City's Zoning Map. Properties to the west are designated as Residential Single Family (RSF 4).

NO MENTION OF THE RESIDENTIAL PROPERTIES DIRECTLY ACROSS THE CANYON FROM THE PROJECT

#### 2.1.3. Project Characteristics

The proposed project includes expanding the existing South Shores Church (SSC) by adding a net floor area of approximately 46,817 square feet to provide a Preschool/Administration Building, a Community Life Center (fellowship hall/gymnasium), and two Christian Education buildings. The City's General Plan and zoning designate the site as Community Facilities (CF). The proposed project uses are consistent with the land use designation and existing zoning.

The proposed Master Plan is shown in Exhibit 2-4 (page 2-9). The existing Preschool, the Administration & Fellowship Hall, and the Chapel will be demolished and replaced with a new



Preschool/Administration Building, a Community Life Center, and two Christian Education buildings. The SSC would be increased by 46,817 square feet and would encompass a total floor area of 89,362 square feet when completed. No changes are proposed to the 584-seat Sanctuary seating. The church would continue to operate during construction of the proposed project. The existing surface parking area that encompasses 228 spaces will be replaced with a two-level (one level is below grade) parking structure along the westerly limits of the property. The proposed project will provide a total of 421 parking spaces. The parking will include 63 on-site surface parking spaces, 179 parking spaces on the first floor (below grade) of the parking structure, and 179 parking spaces on the second floor of the parking structure. The parking complies with City parking code requirements. During construction, overflow parking will be provided at the Strands Beach Parking Lot (off Selva Road) per off-site parking agreements.

The project will continue to have access to Crown Valley Parkway at two driveways. The northerly project access at the intersection of Crown Valley Parkway and Sea Island Drive is signalized and provides full access, while the southerly project access is restricted to right turns in/out only. The southerly driveway (closest to Pacific Coast Highway) will provide access to the upper level of the parking deck. The signalized access at the main entry drive of the church will be redesigned and constructed to align with the existing Sea Island Drive (no changes are proposed to the Sea Island Drive intersection). Each component of the proposed Master Plan (refer to Exhibit 2-4, page 2-9) is described below.

### **Preschool/Administration Building**

The Preschool/Administration Building is the first new building to be constructed. This building is 15,115 square feet in size and has been designed to meet code. This two-story structure is approximately 31'-0" in height (to the top of parapet for a flat roof). The ground level/lower level is partially below the existing grade along the west and north elevations. The Preschool is located on the ground level/lower level and is comprised of six classrooms (two with accordion walls to provide for larger spaces when needed), staff offices, janitor room, restrooms, break room and miscellaneous mechanical and workroom spaces. The Administration functions are located on the upper floor and include staff office spaces, a break room, a prayer room, and a multi-purpose room to provide for large meeting needs and fellowship functions. Operating hours for the aforementioned functions are Monday through Friday mid-September to mid-June from 9:00 a.m. to 2:00 p.m. for the Preschool and from morning to evening for Administration operations. As the first new building constructed, the Preschool/Administration building will also serve some evening functions in the multi-purpose room, or other, during the week to provide for both church ministries and various community groups which use the church facilities for weekly/monthly meeting purposes, including but not limited to the Cub Scouts and local neighborhood home owner associations. These activities take place typically during mid-week evening hours concluding by 10:00 p.m.



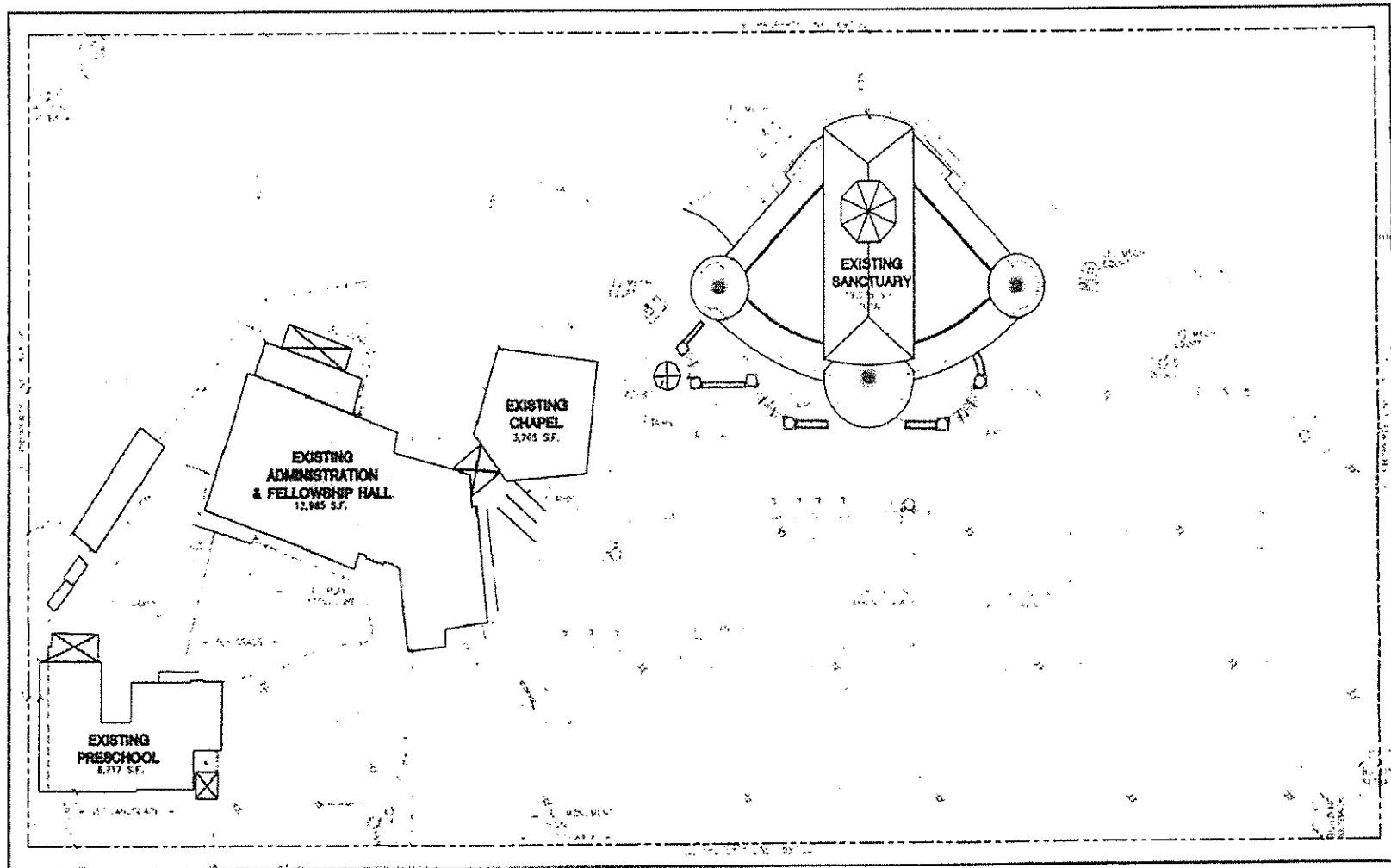

Exhibit 2-3 - Existing Site Plan

As the first new building on campus, and until remaining phases are constructed, Saturday and Sunday functions are anticipated, with Sunday functions as the primary use allowing for ministry and Christian Education opportunities to occur for children through adults from approximately 8:30 a.m. to 1:00 p.m., with possible ministries using some spaces on Sunday evenings also. The Preschool will be located in this building until construction of the final location on site, on the north-end of the campus, in Phase 3. Following the construction of Phase 3, this building will undergo renovations to the lower level to convert spaces for administration needs and adult opportunities. Lastly, the aforementioned weekend and evening functions described will be further accommodated in the buildings on the north-end of the campus as they come to fruition with each phase of construction as well, thereby decreasing the use of this building over time.

### Community Life Center

The new Community Life Center is the second new building to be constructed. This building is proposed to have a floor area of 24,314 square feet. The building has been designed to meet code and is 31'-0" or less in height to the top of parapet for a flat roof and is approximately 35'-0" in height to the peak of the ridge for a gable roof. It is a two-story building, with the ground level/lower level partially below grade along the west, north, and south elevations. The Fellowship Hall/Gymnasium functions planned for this building are located on the ground level/lower level and are flanked on the south and east with support spaces comprised of storage, platform, racquetball, restrooms, kitchen and other functions, such as two classrooms: with an accordion wall to provide for larger gatherings when needed, staff offices, and maintenance. Operations during the week and weekends will proceed in accordance with City of Dana Point noise ordinance guidelines for hours of operation and noise levels. The Fellowship Hall function on this level will accommodate church-wide dining/luncheons, meetings, ministries, and fellowship programs and functions. Gymnasium functions are anticipated to accommodate the Preschool activities during various times of the week throughout the preschool year for physical education opportunities. Additional use is anticipated by all ages from children through adult for various exercise, ministry outreach, and ministry program opportunities during the week and on weekends. Support spaces will operate in conjunction with these opportunities during similar days and times as necessary. Maintenance activities will typically follow the Administration hours for operation, with staff as needed to facilitate functions for set-up and take-down needs. Mid-week evening ministry opportunities will be provided to accommodate programs for youth through young adults. Sundays will allow for youth and adult Christian education ministries and afternoon luncheons following Sunday services. The upper level is comprised of five Classrooms (one with an accordion wall to provide for larger gatherings when needed), restrooms, and a mechanical room. Functions on this level will serve youth through adults providing for Christian education ministries occurring on Sundays and mid-week as necessary in conjunction with ministry opportunities/church service times. There are three services on Sunday mornings: 8:15 a.m., 9:30 a.m., and 11:00 a.m. Sunday evening service is at 6:00 p.m. Mid-week ministries occur during evening hours.

### Christian Education Building 1

Christian Education Building 1 is proposed to be constructed following the Community Life Center. This building encompasses 15,399 square feet of floor area. The building has been designed to meet

code and is approximately 31'-0" in height (to the top of parapet for a flat roof). It is a two-story building, with the ground level/lower level partially below grade along the west and south elevations. Christian education and nursery area are located on the ground level/lower level and will be composed of four classrooms for children/youth Christian education (one with an accordion wall to provide for larger space when needed), nursery check-in, classrooms, restrooms and various mechanical and storage rooms. These functions will operate primarily during Sunday services, with mid-week and weekday functions occurring on an as-needed basis. For example, the Christian education classrooms may be used to accommodate mid-week youth and adult ministry programs and activities during evening hours. The upper level is comprised of two multi-use rooms with an accordion wall for larger needs, a kitchen, restrooms, storage, and a church bookstore. The functions for this level will primarily occur on Sundays in conjunction with Sunday services and will also provide for mid-week evening programs. The bookstore will serve the church congregation and visitors on Sundays, with potential weekday opportunities as well. Fellowship functions will typically take place in the multi-use rooms on an as-needed basis in conjunction with Sunday services and will also provide for weekday and evening mid-week opportunities. Like the meeting spaces available after construction of the Community Life Center (Classrooms), ministries and outside community groups such as those mentioned for the Administration Building characteristics will likely be scheduled for functions in this building in lieu of the Administration Building.

### Christian Education Building 2

Christian Education Building 2 is the final new building to be constructed on the site. This building is proposed to encompass a floor area of 15,456 square feet. The building has been designed to meet code and is approximately 31'-0" in height (to the top of parapet for a flat roof). It is a two-story building, with the ground level/lower level partially below grade along the west and north elevations. Christian Education facilities are located on the ground level/lower level and are comprised of eight classrooms for children/youth/adult Christian education (with accordion walls between them to provide for four individual larger spaces as needed). Restrooms and various mechanical and storage rooms are also located on this level. These functions will operate primarily during Sunday services, with mid-week functions occurring on an as-needed basis. For example, the Christian education classrooms may be used to accommodate mid-week youth and adult ministry programs during evening hours. Weekday ministry opportunities may also occur in these classroom spaces. The upper level provides for the Preschool and is comprised of eight classrooms (with accordion walls between them to provide for four individual larger spaces as needed), offices, teachers lounge, restrooms, and storage. Preschool functions will take place Monday through Friday mid-September to mid-June from 9:00 a.m. to 2:00 p.m. Like the meeting spaces available after construction of the Community Life Center (Classrooms), ministries and outside community groups such as those mentioned for the Administration Building may also be scheduled for functions in this building on the lower level on an as-needed basis for weekday and mid-week ministry opportunities. Following construction of the Preschool, the Administration Building on the south end of the campus will be renovated to convert spaces for administration needs and adult opportunities.

## 2.2 Project Construction and Phasing

The project will be constructed in several phases, commencing in approximately late 2009. Table 2-1 (page 2-14) reflects the sequence of development proposed for the South Shores Church; Exhibit 2-8 through Exhibit 2-11 illustrate that development phasing. Each of the phases identified in the above-mentioned Exhibits will occur individually and the previous phase will be completed prior to initiation of the subsequent phase. As indicated in Table 2-1, Phase 1 encompasses three subphases, including the demolition of three of the existing buildings. In Phase 1A, the Administration Building will be constructed near the southeast corner of the project site. In conjunction with this phase, the Preschool will be relocated into this building until the Christian Education Building 2 is completed in Phase 3. Upon completion of Phase 1A, the existing Preschool, the Administration & Fellowship Hall, and the Chapel buildings located near the north end of the project site will be demolished as part of Phase 1B. In Phase 1C, a new Community Life Center will be constructed at the northwest corner of the site. Phases 2 and 3 include the construction of two new Christian Education buildings located along the east side of the northern portion of the project. Following completion of the second Christian Education building, the Preschool will be relocated into the newly constructed building and the portion of the Administration Building, which was previously occupied by the Preschool, will be renovated for administrative uses. The final two phases of construction (i.e., Phases 4 and 5) include the construction of a two-level parking structure on the west side of the project site. The parking structure will be completed in two phases with the south half being completed first (Phase 4) and the north half being constructed thereafter (Phase 5).

Table 2-1 also provides a summary of the existing uses on site, the net increase in floor area anticipated as a result of project implementation, and the order in which phasing of the project will transpire.

Table 2-1 - Master Plan Summary

Phase	Description	Floor Area (Square Feet)		
		Add	Demolish	Total
1A	Construct New Preschool/Administration Building	15,115		57,660
1B	Demolition of Existing Preschool Chapel, and Administration Buildings		23,467	34,193
1C	Construct New Community Life Center	24,314		58,507
2	Construct New Christian Education Bldg. 1	15,399		73,906
3	Construct New Christian Education Bldg. 2 <sup>1</sup>	15,456		89,362
4	Construct South Half of Parking Deck <sup>2,3</sup>			89,362
5	Construct North Half of Parking Deck <sup>4</sup>			89,362
		70,284	23,467	46,817 <sup>4</sup>

1 Preschool Moves into Christian Education Building. No changes in student capacity proposed.

2 Interior renovation of Administration Building area previously occupied by preschool at same time.

3 Parking to be accommodated with offsite agreement for use of the Strands Beach Parking Lot (off Selva Road).

4 Net increase in floor area

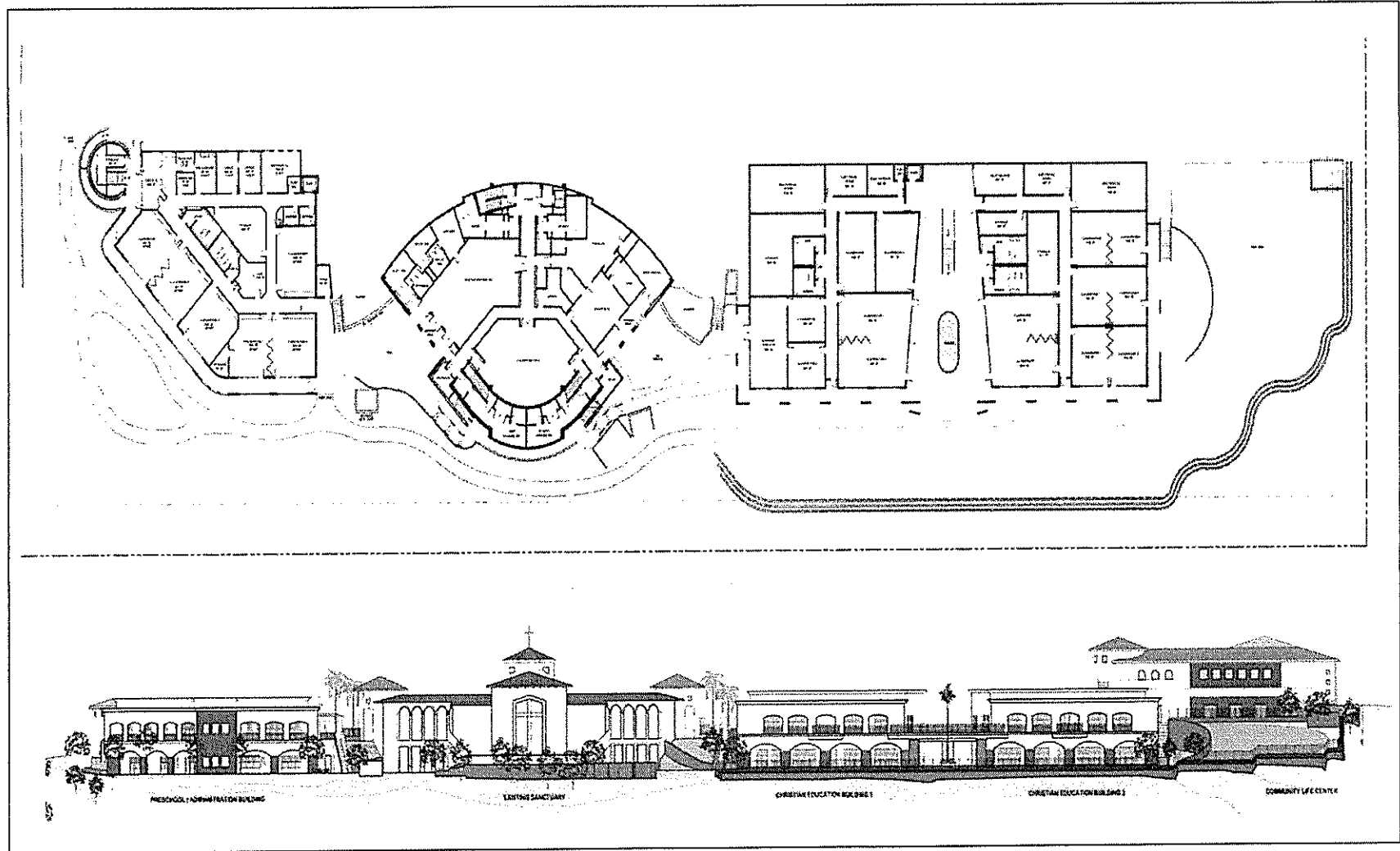

Exhibit 2-3 - Lower Level/Hillside

THIS ELEVATION CLEARLY DEMONSTRATES THAT WE WILL BE FACING ALMOST FOUR STORIES, NONE OF WHICH ARE BELOW GRADE. THE CHURCH MAKES A GREAT POINT OF MITIGATION BY PUTTING FACILITIES BELOW GRADE. THAT'S SIMPLY NOT TRUE.

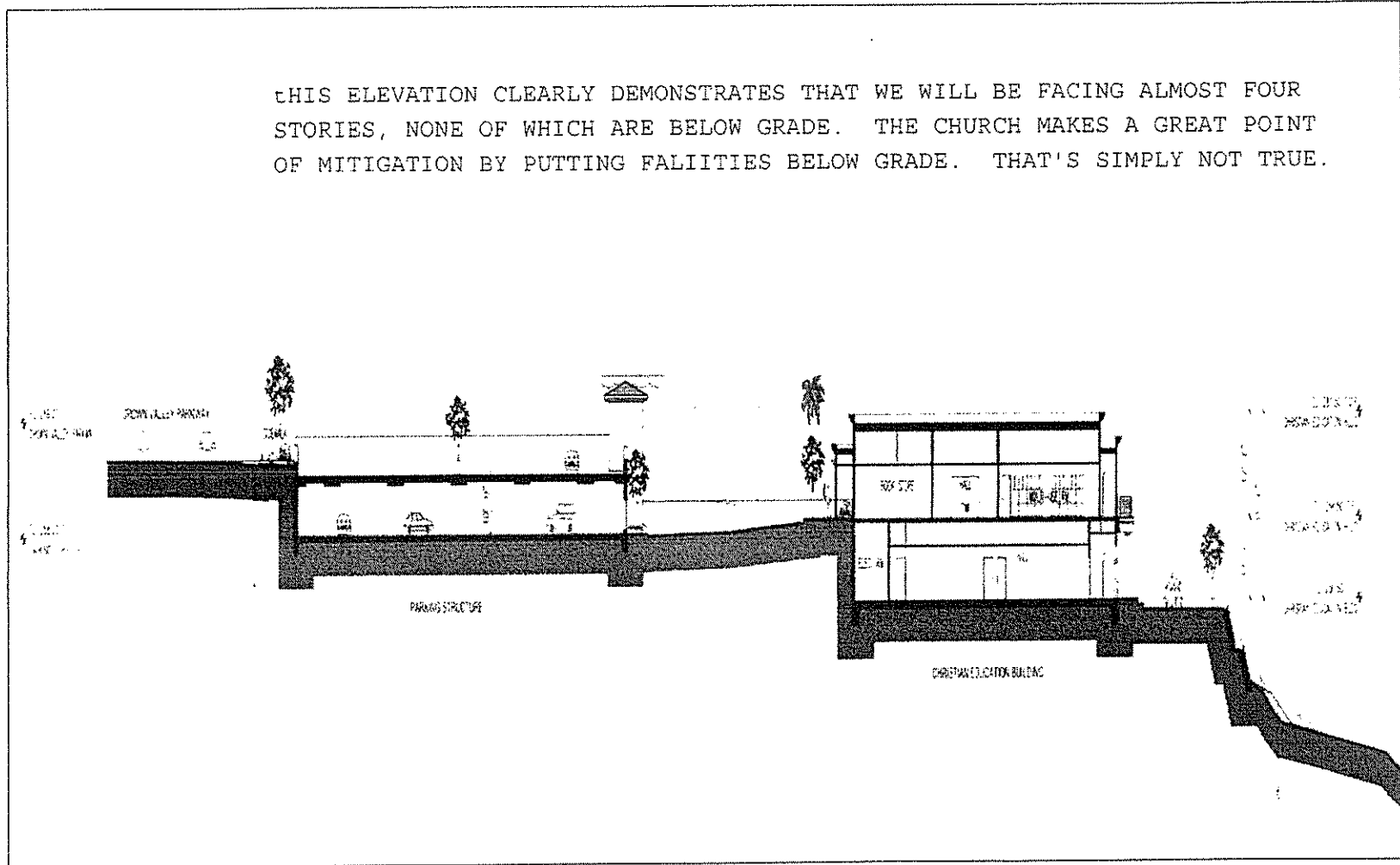

Exhibit 2-6 - Parking Structure and Christian Education Building Elevation Section



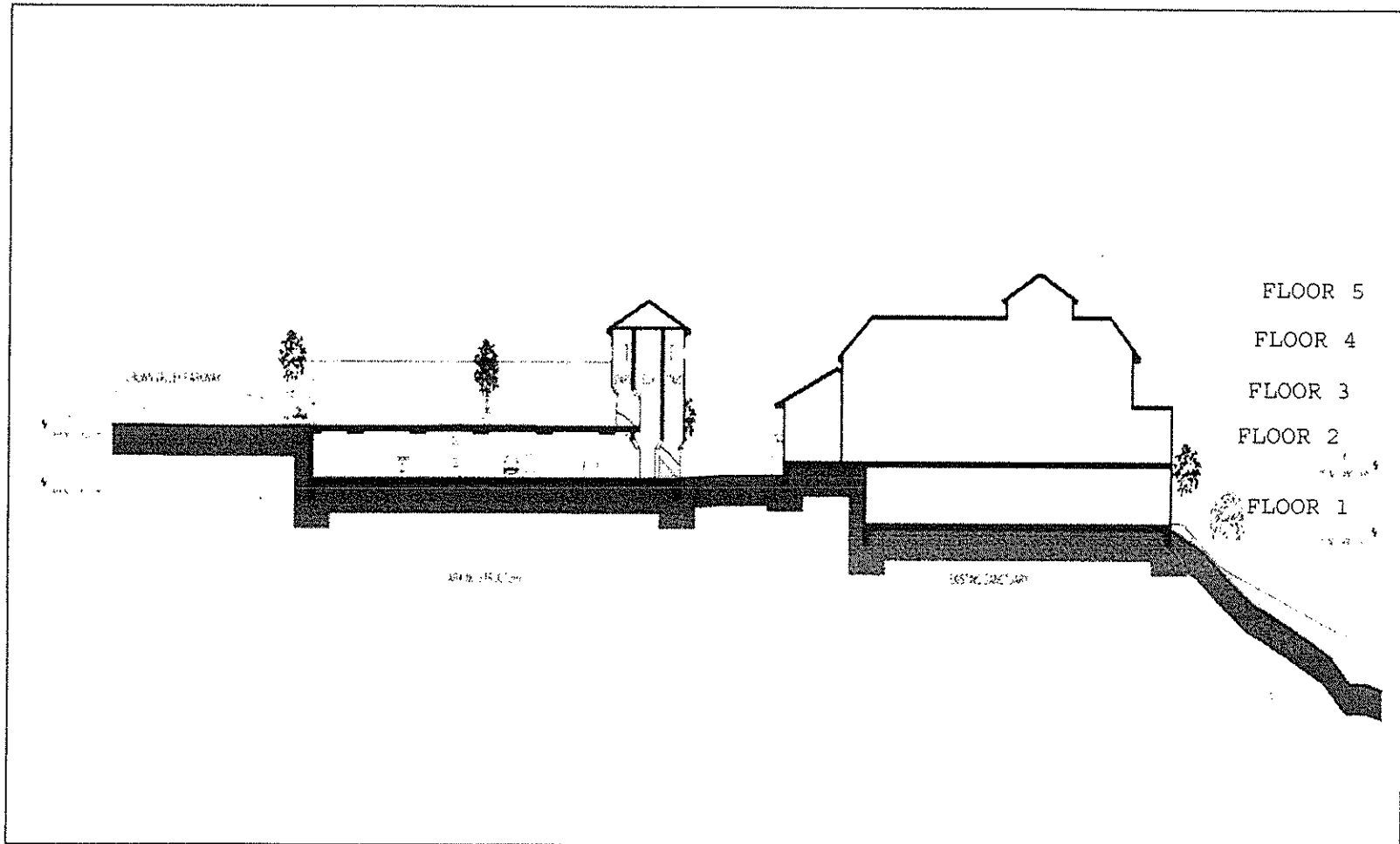

Exhibit 2-7 - Parking Structure & Existing Sanctuary Elevation Section



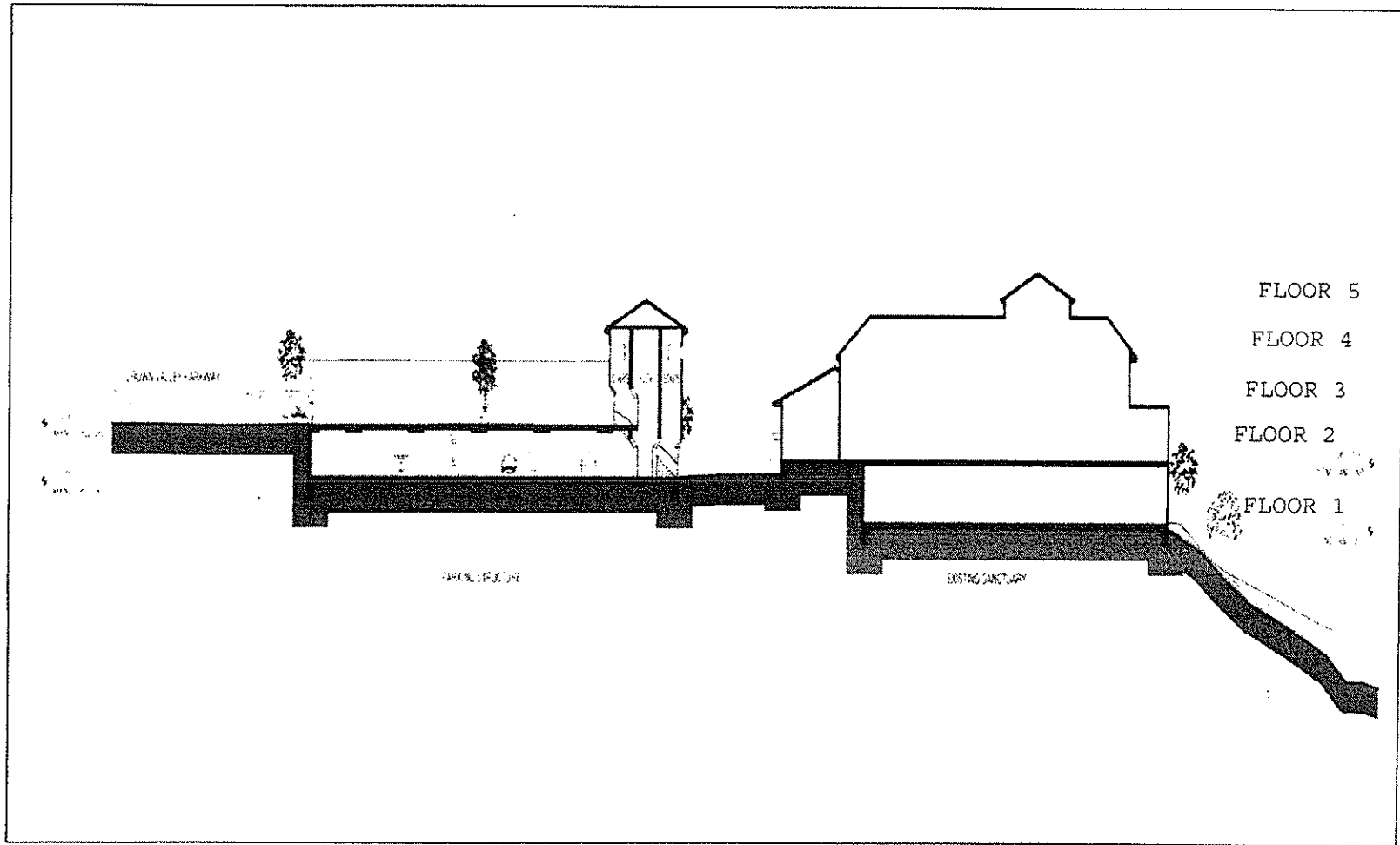

Exhibit 2-7 - Parking Structure & Existing Sanctuary Elevation Section

### 2.3 Project History and Background

The project site was originally developed with a single-family residential use in the 1950s. The property owner evaluated offers to purchase the property for future development of several uses, including a church. The previous owner decided that the best use for the property would be a church that would serve the community. Therefore, the church has been operating on the site since the late 1950s. Master planning for the potential future uses of the church campus began in the 1970s. Sunday services were held in the small chapel (youth building) until the current 584-seat sanctuary was built in the mid 1990s. In 2000, church volunteers initiated the past Master Plan discussions and pursued evaluating how the property could be utilized in a way to provide the needed facilities to serve the Christian ministry. In 2002, the church formed a building committee to work with architects to develop a Master Plan for the property. In 2004, the South Shores Church submitted the Master Plan to the City of Dana Point. In that same year, modifications were incorporated into the Master Plan as a result of comments received during the architectural review process as well as comments NONE HERE from the City and nearby homeowners/residents during neighborhood meetings held by the church. The current Master Plan was resubmitted to the City in 2006. The most significant changes to the plan included architectural modifications that complement the existing sanctuary, a parking structure that preserves the view corridor across the site towards the golf course and ocean (one level of parking is underground), redesigning the Christian Education buildings from three structures to two structures, and further increasing the setbacks of the proposed Administration Building. From 2006 through 2008, technical studies (i.e., geotechnical, hydrology/water quality, air quality, biology, noise, traffic/parking) were undertaken to evaluate the proposed Master Plan and project site.

## 3. Analysis

### 3.1 Aesthetics

The proposed project will not result in any significant environmental impacts to aesthetics. The project has been designed to avoid potential aesthetics impacts, including those that could occur with construction of the proposed buildings and parking structure. The proposed project has incorporated reduced building heights and increased building setbacks to address potential visual impacts. In addition, the parking structure has been designed with one subterranean level and to incorporate an architectural character that complements the existing church sanctuary. The project does not result in any significant impacts to a scenic vista or to scenic resources. NOT TRUE

All new building heights meet City development code requirements, with parapet heights equaling 31'-0" or less for flat roofs and peak ridge heights equaling 35'-0" or less for gable roof areas. Combinations of varying contextual roof design elements and roof heights further serve to create aesthetically compatible relationships and avoid excessive massing. With the exception of the building setback lines directly adjacent and parallel to Crown Valley Parkway, all buildings and structures proposed exceed the minimum setback requirements established by the existing zoning. Careful consideration was given to site building and structures taking into account proximity to neighboring properties and potential sightlines. All buildings and structures take advantage of the existing topography by incorporating partial subterranean levels as well, decreasing building heights as viewed from Crown Valley Parkway. The parking structure was also designed to address the aesthetic character of the area by proposing the lower level of parking to be partially below grade, thereby decreasing the height of the structure as viewed from Crown Valley Parkway. Additional aesthetics improvements that complement the architectural style of the existing Sanctuary to remain were incorporated into the overall project during design and also respond to public comments expressed during the community participation process.

The following analysis provides explanation for the conclusions contained in the Environmental Checklist (presented in Appendix A of this document). The analysis describes the physical environmental impacts that would result due to the development and operation of the proposed project. Based on the following analysis, the project does not result in any significant impacts to a scenic vista or scenic resources.

**a) Would the project have a substantial adverse effect on a scenic vista? (*Less Than Significant Impact*)**

The project proposes the implementation of a Master Plan, including the construction of a new Community Life Center (Fellowship Hall/Gymnasium), replacement and construction of a new Administration Building and Christian Education Buildings, and construction of a two-level (one subterranean level) parking structure as identified and description in Section 2.0.

The proposed Administration Building (also to be used temporarily for Preschool until the two Christian Education buildings are completed) is a two-story structure totaling 15,115 square feet in

size. The existing topographic conditions as well as proximity to the adjacent residential properties were major considerations in the location and design of this building. In order to ensure that potential visual impacts are avoided or minimized, the closest element of the proposed building to the adjacent Monarch Bay Villas property is approximately 36'-0" from the property line, which exceeds the minimum required 10'-0" setback. The building then angles north, decreasing the massing of the building elevation, which decreases potential pedestrian sightlines from the naturally occurring elevated nature of this building to neighboring residences due to the topography. The Administration Building is also located in excess of the minimum building setback requirement to provide a greater buffer between the buildings for the Monarch Bay Villas and the SSC.

Though this building will primarily serve Administration upon full project completion, it should be noted that, during the sequencing of construction phasing, it will temporarily serve to house the Preschool, some ministry programs, and fellowship functions. The Preschool operations will occur during weekdays only, Monday through Friday morning to mid-afternoon, with no school during the summer. Outdoor play areas take into account proximity to neighboring residents: a portion of the play area will be provided in the existing parking lot via the use of a roll-out and roll-up resilient play surfacing along with temporary safety fencing. Temporary fencing will also be used for visual buffering and dust control during project phasing to minimize visual impacts to neighboring residents.

The proposed Christian Education buildings (two-stories each, 15,456 square feet and 15,399 square feet in size) are proposed to be located adjacent to the existing church sanctuary on the northeast area of the property. These buildings are approximately 31 feet high and face towards the back of the property and to the north (adjacent to the Monarch Apartments). The height of the building portion that is closest to the sanctuary is approximately 17'-6". The proposed Community Life Center (Fellowship Hall/ Gymnasium) building, which encompasses 24,314 square feet, is located in the northwesterly area of the site near the intersection of Crown Valley Parkway and Sea Island Drive. This two-story building is approximately 35 feet high.

The proposed two-level parking structure (deck) and surface parking will provide a total of 421 spaces. Currently, the SSC has 228 surface parking stalls. Although the parking structure is proposed to be two levels, one level will be below grade. The parking structure is designed so that a significant portion of it is within a few feet in height above the existing grade of Crown Valley Parkway. The parking structure (in addition to the Administration Building) has been designed and located within the property to preserve the view corridor that extends through the church property from surrounding uses towards the golf course and the ocean. The parking structure was given careful design consideration in this vicinity. The structure is located 20'-0" from the south property line, which exceeds the minimum required 10'-0" setback. In addition, a two-way vehicular access ramp from the lower level to the upper level is designed, which improves existing conditions by locating parked vehicles approximately 45'-0" away from nearby residents, compared to the approximately 15'-0" that currently exists. Further design consideration (e.g., type of ramp surface materials) will be given to this vehicular ramp during construction documentation to provide elements as deterrents for skateboarding, while further minimizing vehicular noise as well. By locating the vehicular ramp in the proposed location and by varying its height, the overall height and massing of the parking

structure has been softened and its effect on the visual character when viewed from the adjacent properties has been minimized.

Photo simulations (existing and proposed views) are presented in Exhibit 3-1 through Exhibit 3-5 illustrate the view from Crown Valley Parkway looking south towards the church. The proposed view shows the site with the development of the Community Life Center building (Fellowship Hall/Gymnasium), which will replace the existing buildings shown in the photo. The proposed view shows that the new Community Life Center and the existing structures will be visible from this vantage. However, the view will not be substantially different from that which currently exists and the character of the building will be compatible with the nearby development.

The Exhibit 3-2 view is taken from Sea Island Drive and Crown Valley Parkway intersection looking easterly towards the church. This view illustrates the development of the Community Life Center and Christian Education buildings as it would be viewed from this location. The existing view shows that the current buildings are visible to surrounding residences and those traveling on Crown Valley Parkway. The proposed view illustrates that the new Community Life Center and Administration Building would also be visible to the residences in the immediate area and motorists (bicyclists and pedestrians) utilizing Crown Valley. However, as indicated above, the architectural design and incorporation of landscaping will ensure that the visual character of the area is maintained

The Exhibit 3-3 view illustrates the future view from Crown Valley Parkway looking across the roadway towards the existing church sanctuary. The visual simulation shows the development of the Administration Building and the parking structure. This view illustrates that the two-level parking structure (one-level below grade) will not result in a significant visual impact because the parking structure and the Administration Building have been designed to preserve the view across the church property and provide an open view to the church and areas beyond (e.g., golf course and ocean). As reflected in that simulation, the landscape design will further soften the views of the proposed development when viewed from this vantage.

The Exhibit 3-4 and Exhibit 3-5 views are from the St. Regis Golf Course area looking towards the church and surrounding residential development. The proposed view shows the project site with the existing sanctuary (no changes are proposed) and also with the Administration Building and the two Christian Education Buildings. These more distant views to the subject property from the golf course reveal that the proposed structures will not substantially alter the existing aesthetic character of the area. As previously indicated, the new buildings have been designed to be compatible with the existing development both on the site and in the vicinity of the property.

THEY WENT AS FAR SOUTH AS  
THEY COULD TO MINIMIZE  
IMPACT

The proposed new buildings will be visible from many locations within and around the immediate area. The proposed buildings replace existing buildings (with the exception of the sanctuary) that are already visible from these locations and have been for over 40 years. The project site is designated as Community Facilities per the City's General Plan and zoning (Figure PF-2 of the General Plan). This designation allows for a wide range of public and private uses including churches, schools, child care center, government offices, community theaters and recreational activities. Crown Valley Parkway (adjacent to the site and provides access to the property) is designated as a Major Arterial Highway per the Circulation Element of the City's General Plan. The Circulation Element also identifies Crown Valley Parkway as a scenic highway (Figure C-6 of the General Plan). The Circulation

Element (page 28) designates Crown Valley Parkway among the routes considered to be potential scenic corridors. As such, the roadway is constructed in conformance with the design elements of the Dana Point Landscape Corridors (e.g., raised landscape median). The proposed project design complies with the requirements pertaining to building heights and setbacks. The proposed project also complies with the City's Urban Design Element, which articulates policies and design concepts for the preservation of the natural setting, public improvements, form and character of new private development, and focused plans for areas within the City. This element addresses the following: 1) Citywide Visual Linkage, 2) Communities of the City, 3) Town Center, 4) Public Spaces, 5) Design Quality, 6) Doheny Village, and 7) Marine Resources. The project is consistent with Policy 1.4 of the Element, which promotes the preservation of public views from streets and public places, consistent with Section 30251 of the Coastal Act. The project has also provided a design for the parking structure, which proposes one level below grade. As a result, views across the church property in the direction of the golf course and ocean will not be obstructed. The project will also include landscaping which is illustrated in Exhibit 3-6.

The Conservation/Open Space Element of the General Plan identifies the Salt Creek area (and golf course area) as providing scenic view resources. The project site (and immediate bluff top area) are not designated scenic vistas. However, the project has been designed to reduce potential aesthetics impacts and preserve the scenic character of the property's location and surroundings through its architecture and landscape design. In addition, the project complies with building height and setback requirements and the architecture complements the existing church sanctuary, which will remain. Although the proposed project will be visible to surrounding and immediate areas, which include residential uses, a hotel, golf course, Salt Creek Trail, and pedestrians and motorists, potentially significant visual impacts will not occur as a result of the implementation of the project design features and elements (e.g., architectural character, landscape plan).

The site is currently developed with an existing church and parking. The property was previously graded in conjunction with the existing church uses and the previous residential use (in the 1950s). Grading and development in the immediate area associated with residential uses and Crown Valley Parkway have also taken place, which have altered the natural character of the site within the viewshed. As previously indicated, the "redevelopment" of portions of the site with new buildings that have been designed to be compatible with the surrounding area will not result in potentially significant visual impacts. SIGNIFICANTLY EXPANDING BOTH THE DISTURBED AREA AND THE BUILDING AREA AS WELL AS THE IMPACT ON THE DISTURBED SLOPE

The project has been designed in compliance with applicable development regulations in addition to being consistent with the goals and objectives identified in the City's General Plan. The land use section of this environmental document provides further discussion and analysis of the project consistency with the General Plan (e.g., Land Use).



Although construction activities would change views to the site, these effects will be temporary and will cease upon completion of the construction, which will occur in phases. Construction staging areas will be located on-site and will occur in close proximity to the construction area as well as utilizing an area of the surface parking lot. It is anticipated that temporary fencing (with shielding) will be put in place to further reduce the nuisances typical of construction activities (such as dust, noise). Potential impacts relative to visual (scenic) resources have been reduced by the design of the project and landscaping that will be implemented to further soften and enhance the property and surroundings. In addition, the project must comply with the City's development regulations and applicable design guidelines adopted by the City, which are included in the General Plan to ensure that no significant impacts to the visual environment occur as a result of the proposed new development. Although no significant visual impacts are anticipated, the mitigation measure presented below would ensure that the project landscaping design provides an aesthetically compatible development that complements the existing surrounding uses.

MM 3.1-1 Prior to the issuance of a building permit (for each phase), a final detailed landscape plan (addressing each phase of construction) shall be prepared by a licensed landscape architect for the project for review and approval by the Director of Community Development. The landscaping shall be installed in recognition of vehicular and pedestrian circulation (e.g., site distance considerations) and safety.

**b) Would the project substantially damage scenic resources, including, but not limited to trees, rock outcroppings, and historic buildings within a State scenic highway? (*Less Than Significant Impact*)**

As previously noted, the site has been previously graded to accommodate the existing church (and former residential use). As a result, it is devoid of important scenic and/or aesthetic features such as rock outcroppings and heritage trees. Furthermore, none of the existing structures on the subject property are historic in nature and the site is not located within a State scenic highway corridor. Therefore, project implementation will not substantially damage scenic resources. The project will include implementation of landscaping following completion of each phase of construction to ensure that adequate aesthetic treatment is provided to enhance the character of the site within the project area. As a result, no significant impacts to scenic resources (e.g., rock outcroppings, trees) are anticipated and no mitigation measures are required.

**c) Would the project substantially degrade the existing visual character or quality of the site and its surroundings? (*Less Than Significant Impact*)**

Construction activities (e.g., construction equipment, vehicles, supplies/materials, workers) will be visible to the existing surrounding uses (e.g., nearby residences, golf course, Salt Creek Trail) and adjacent roadway vehicle and pedestrian traffic. The visual impacts associated with the construction of the project are short-term and will cease upon completion of each phase of construction. Therefore, these temporary effects are not considered significant impacts. To ensure that the visual integrity of the site is maintained during construction, temporary fencing and screening will be installed around equipment staging areas and spoil stockpiles that will minimize the effect of the construction activities that are typical of a construction project.

As previously indicated, the proposed project has been designed to be aesthetically compatible with the existing uses in the surrounding area. As a result, project implementation will not result in visually obtrusive elements when viewed from nearby areas, including the adjacent homes, nearby golf course and trail, and from Crown Valley parkway. Although the project will result in the intensification of the existing church use (e.g., additional building square footage) compared to that which currently exists, the project has been designed to complement the character of the existing sanctuary, conform topographically to the site, and be aesthetically compatible with the surrounding (adjacent) residential uses. Over time, the proposed project will result in the replacement of existing structures with new, modern buildings that are suited to the property and project environs. The project has been designed to comply with the relevant policies articulated in the City's General Plan (e.g., the Land Use Element and Urban Design standards). Based on the design of the project, which incorporates landscaping and elements and features that complement the existing sanctuary and nearby residential development as well as the consistency with the Urban Design Element, project implementation will not substantially degrade the visual character or quality of the site and its surroundings. No significant impacts are anticipated and no mitigation measures are required.

**d) Would the project create a new source of substantial light or glare which would adversely affect day or nighttime views in the area? (*Less Than Significant Impact*)**

Exterior lighting proposed for the project will be designed and installed in accordance with Section 9.05.220 of the City's Zoning Ordinance, which stipulates that:

“Exterior lighting shall be energy-efficient and shielded or recessed so that direct glare and reflections are contained within the boundaries of the parcel, and shall be directed downward and away from adjoining properties and public rights-of-way. No lighting shall blink, flash, or be of unusually high intensity or brightness. All lighting fixtures shall be appropriate in scale, intensity, and height to the use it is serving.”

The applicant has submitted a preliminary lighting plan, which indicates that proposed lighting will not spill onto adjacent properties. Nonetheless, the City of Dana Point requires the submittal of a final lighting plan, which must comply with Section 9.05.220 of the Municipal Code: the final lighting plan would be approved prior to issuance of any building permit. With implementation of design measures prescribed in the Municipal Code for lighting and reflected in the final lighting plan, which address the requirements for types of fixtures, light shielding, non-glare building materials, potential significant lighting impacts will be avoided.

WE'RE GOING TO HAVE LAS VEGAS LIGHTING SHINING INTO OUR BEDROOM

### 3.3 Air Quality

An Air Quality Assessment for the proposed project was prepared by Mestre Greve Associates dated October 2005 and updated in May 6, 2008 and November 21, 2008. The air quality report was updated to reflect changes in the project grading (excavation) as a result of further geotechnical analysis that was conducted for the proposed project. The grading (and air quality assessment) of potential impacts represents a "worst case" scenario (in term of environmental evaluation) that could occur as a result of geotechnical remediation. The air quality assessment is hereby incorporated by reference and is included in Appendix B of this document. The air quality study analyzed the potential air quality impacts associated with the proposed project and regional air quality impacts from construction and operation of the project. The Air Quality Report also includes data (from 2003 to 2006) for monitored air quality levels measured at the Mission Viejo Monitoring Station. This data is considered representative of the air quality experienced in the vicinity of the project. The following sections provide an analysis of the existing air quality, potential project impacts, and recommended mitigation measures. The proposed project will not result in any significant impacts to air quality. All potential impacts can be mitigated to a less than significant level. Impacts associated with the project include those that will occur as a result of demolition of existing structures, grading and construction activities. With implementation of mitigation measures consistent with the rules and regulations of the South Coast Air Quality Management District (SCAQMD) and the City of Dana Point, all short-term impacts are reduced to a level of less than significant. Additionally, with implementation of recommended mitigation, the construction related air emissions are below significance thresholds established by the SCAQMD.

**a) Would the project conflict with or obstruct implementation of the applicable air quality plan? (*No Impact*)**

The project site is located in the South Coast Air Basin (SCAB). The South Coast Air Quality Management District (SCAQMD) sets and enforces regulations for stationary sources in the basin and develops and implements non-transportation control measures. The California Air Resources Board (CARB) is charged with controlling motor vehicle emissions. CARB establishes legal emissions rates for new vehicles and is responsible for the vehicle inspection program. Other important agencies in the air quality management field for the basin include the U.S. Environmental Protection Agency (EPA) and the Southern California Association of Governments (SCAG). The EPA implements the provisions of the Federal Clean Air Act. This Act establishes ambient air quality standards that are applicable nationwide. In areas that are not achieving the standards, including the South Coast Air Basin (SCAB), the Clean Air Act requires that plans be developed and implemented to meet the standards. The EPA oversees the efforts of SCAQMD in improving air quality in this air basin and ensures that appropriate plans are being developed and implemented. The primary agencies responsible for establishing and implementing the regional air quality plan are SCAG and the SCAQMD. Every three years, the SCAQMD prepares an overall Air Quality Management Plan (AQMP) for the air quality improvement to be submitted for inclusion in the State Implementation Plan (SIP). Each iteration of the plan is an update of the previous plan. The Final 2007 AQMP was adopted by the AQMD Governing Board on June 1, 2007. SCAG prepares the transportation component of the AQMP.

standard or contribution to an existing or projected air quality violation. The following is a summary of the short-term and long-term air quality impacts evaluated in the Air Quality Assessment and the results of the analysis.

### Short-Term Air Quality Impacts

Short-term impacts are usually the result of construction or grading operations. The "1993 CEQA Air Quality Handbook" by the SCAQMD has established significance thresholds to assess the regional impact of project related air pollutant emissions. Table 3-1 presents these significance thresholds. A project with daily emission rates below these thresholds are considered to have a less than significant effect on regional air quality throughout the South Coast Air Basin.

Table 3-1 - SCAQMD Regional Pollutant Emission Thresholds of Significance

	Pollutant Emissions (lbs/day)				
	CO	SO <sub>x</sub>	ROG	NO <sub>x</sub>	PM <sub>10</sub>
Construction	550	150	75	100	150
Operation	550	150	55	55	150

Temporary impacts will result from the project's construction activities. Air pollutants will be emitted by construction equipment and fugitive dust will be generated during grading and site preparation. As mentioned previously, per the CEQA Handbook, emission factor for disturbed soil is 0.40 tons of PM<sub>10</sub> per month per acre. If water or other soil stabilizers are used to control dust as required by SCAQMD Rule 403, the emissions can be reduced by 50%.

The proposed project will require grading (cut/fill of earth material). The excavation of the area will consist of a total of approximately 101,359 cubic yards of cut-and-fill (total of all stockpile stages) and occur in five stages. Each stage involves the removal, backfill, and compaction of earth material. Excavation period per stage is anticipated to be between 18 and 22 days for removal, and between 22 and 30 days for backfill and compaction. The total time of excavation is projected to occur between four to five months. The construction equipment involved would include 1 bull dozer, 1 CAT 345 excavator, 2 CAT 637 twin engine scrapers, and a water truck. The following analyses were based on this information. Typical emission rates for construction equipment were obtained from the SCAQMD Air Quality Handbook.

FOR THE NEXT FIVE MONTHS WE WILL NOT BE ABLE TO ENJOY OUR HOUSE DURING THE DAY WHEN WE ARE ALWAYS HOME  
**Localized Significant Thresholds (LSTs)**

The SCAQMD developed localized significance threshold (LST) methodology and mass rate look-up tables by source receptor area (SRA) that can be used to determine whether or not a project may generate significant adverse localized air quality impacts. LSTs represent the maximum emissions from a project that will not cause or contribute to an exceedance of the most stringent applicable federal or state ambient air quality standard, and are developed based on the ambient concentrations of that pollutant for each source receptor area. The LST mass rate look-up tables provided by the SCAQMD allow one to determine if the daily emissions for proposed construction or operational

complex organic particulate matter released from combustion sources which are more harmful to health. Care should be taken to minimize the generation of dust. Common practice, which is usually required by regulation, for minimizing dust generation is watering before and during grading. Without watering three times daily, PM<sub>10</sub> and PM<sub>2.5</sub> emission generation would more than double the amount mentioned previously. The air pollutant emissions are presented in Table 3-3.

WHILE WATERING IS NECESSARY TO MITIGATE,

Table 3-3 - Worst Case Peak Construction Emissions WHAT ABOUT THE WATER SHORTAGE

Activity	Pollutant Emissions (lbs/day)					
	ROG	NO <sub>x</sub>	CO	SO <sub>x</sub>	PM <sub>10</sub>	PM <sub>2.5</sub>
Stage 2						
Contingency Plan (May 2008)	3.5	30.3	15.5	0.0	16.0	3.5
Contingency Plan (August 2008)	1.0	13.4	5.0	0.0	0.6	1.0
Combined Emissions	4	44	20	0	17	4
Stage 3						
Contingency Plan (August 2008)	1.0	14.3	5.3	0.7	0.6	1.0
Stage 4						
Contingency Plan (May 2008)	3.5	30.8	15.7	0.0	19.8	3.5
Contingency Plan (August 2008)	2.1	29.0	10.8	0.0	1.3	2.1
Combined Emissions	6	60	27	0	21	6
SCQAMD Thresholds	75	100	550	150	150	55

The results in Table 3-3 above show that the emissions are below than the Significance Emission Thresholds established by the SCAQMD for all criteria pollutants. The primary source of PM<sub>10</sub> and PM<sub>2.5</sub> emissions would be from ground disturbance. However, the project construction emissions for PM<sub>10</sub> and PM<sub>2.5</sub> exceed the LSTs at the nearest residential land uses, resulting in a potentially significant short-term air quality impact. These impacts can be reduced to a less than significant level through compliance with AQMD rules for fugitive dust (e.g., watering, suspending construction operations during high winds). These measures, which require compliance with SCAQMD Rules 402 and 403, identify control measures (e.g., watering, stabilization of surface soils) to reduce particulate emissions.

#### On-Site Grading/Excavation Emissions

Table 3-3 above presents the results of the emissions calculations for the construction activities. This is the grading/excavation and construction equipment emissions and emissions from on-road vehicles traveling outside of the project boundaries. The on-site emissions presented in Table 3-4 are those that would be emitted from activity within the project site including the emissions from vehicles traveling inside the project boundaries. The on-site worker trips were assumed to be approximately 5% of the total worker trips, while the on-site equipment emissions were based on an assumed internal one-way trip length of 0.1 mile. The total on-site construction emissions are compared to the Localized Significance Thresholds (LSTs) presented in Table 3-1 (page 3-24). The results in Table 3-4 show that construction activities will not result in on-site emissions exceeding the LSTs at the nearest residential land uses for PM<sub>10</sub> and PM<sub>2.5</sub>.

detected are those typical of heavy construction vehicles (e.g., diesel exhaust from grading and construction equipment, asphalt, painting, stucco). These odors are not unusual and do not pose a health risk; these emissions are a temporary short-term impact that is typical of construction projects. However, the project does not expose sensitive receptors to substantial pollutant concentrations. Therefore, the proposed project will not result in any significant impacts of objectionable odors affecting a substantial number of people. No mitigation measures are required.

THE EVALUATION DID NOT CONSIDER THE NUISANCE DUST AND NOISE IMPACT ON  
THOSE MOST AFFECTED -- DOWNWIND AND UNPROTECTED BY ANY INTERMEDIATE  
BARRIERS

iv. **Landslides? (Less Than Significant Impact With Mitigation Incorporated)**

The topography of the existing church is relatively flat and located between Crown Valley Parkway and a steep graded and natural slope that descends easterly in the direction towards Salt Creek and an existing golf course. There are existing residences adjacent to the site to the north and south, and residences to the west (across Crown Valley Parkway) and to the east near the golf course and St. Regis Hotel. ONLY ACKNOWLEDGEMENT OF THE EAST

The geotechnical reports prepared by G.A. Nicoll & Associates, Inc. evaluated the geological conditions of the site and proposed project. The geotechnical investigation included field exploration (drilling of borings below the surface) within the church property and in the immediate area offsite (near the proposed Christian Education Buildings). The reports (on file with the City of Dana Point Planning Division) include a map showing the location of the test borings. The subsurface investigation included the following: four borings to depths ranging from 15 to 65 feet; two borings to depths ranging from 64 and 90 feet (in an area that the drill rig met hard rock); and excavation of two trenches to explore for fault features and other subsurface structures.

The project site is underlain by engineered fill deposits, to a maximum depth of 25 feet, at the southeast corner of the site, or by marine, Tertiary age sedimentary rocks of the San Onofre Breccia. The lower, off-site portion of the slope descending easterly to Salt Creek, beyond the property line, is underlain by bedrock of the Monterey Formation, a marine sedimentary rock consisting of relatively weak siltstone and diatomaceous shale. Several landslides have occurred in the lower portions of the slope, within the Monterey Formation, and in the weathered San Onofre Breccia, on and off the site, where tectonic shearing has created planes of weakness, generally along the bedding.

Fill of limited thickness underlies a portion of the site. The fill is beneath a portion of the existing Administration Building and Fellowship Hall and the lawn area and adjacent manufactured slope to the east of the building. The fill thickness ranges from less than a foot to 5 feet. The fill encountered consisted of moist to very moist, firm silty clay and sandy silt with clay, with gravel-to cobble-size rock fragments.

One landslide is present on the site. There are three landslides that are present off site. Landslide Qls<sub>1</sub> is located below the site to the east and movement has occurred in both Monterey and San Onofre bedrock. The slide was encountered during the test borings (borings BN-4, LBA-1 and R-5). The landslide materials consist of weathered, sheared San Onofre Breccia and soft, weathered, tightly-folded and sheared shale of the Monterey Formation. The landslide is covered by fill (earth-dirt) most of its length.

Landslide Qls<sub>2</sub> is located in the northeast corner of the site and extends off site to the east and northeast. The landslide was encountered during the test borings BN-2, BN-3, BN-5 in San Onofre Breccia and in the AGR Borings BB-106 and R-4 below the site, in the San Onofre Breccia and Monterey Shale. Based on the lack of shears in the upper portions of Borings BA-4 and BN-1, the upper limits of Qls<sub>2</sub> are limited to the area east of the north east corner of the proposed Christian Education Building 2. The test boring (BN-3) indicates movement of the landslide occurred to the east, into the valley.

The geotechnical reports identified that based on the results of the subsurface testing, it appears that a possible deeper landslide underlies a portion of the northeast area of the site and the down-slope, off-site area to the east and northeast. No well-developed striations were found on shear surfaces and the bedding and related weak layers within the San Onofre Breccia are typically limited in aerial extent, therefore the geotechnical reports concluded that the deeper disturbed area is a potential landslide. However, to assess the project site for slope stability purposes, the geotechnical reports analyzed the potential slide area as a landslide.

Landslide QLS<sub>32</sub> is located off site to the north and northeast on the Monarch Coast Apartment property at the south end of the apartment complex. The landslide movements have occurred mostly within the weak shale beds of the Monterey Formation and along a rep-existing, ancient landslide plane, damaging the pre-existing apartment Building 32 and the bike path and sewer line below to the east.

Landslide QLS<sub>0</sub> (T<sub>m</sub>) is an ancient landslide that occurred within the Monterey Formation. The landslide is located off site to the north and northeast at the south end of the Monarch Coast Apartments complex. The ancient landslide is partly responsible for the Buildings 32 landslide.

As such, remediation to mitigate the potential effects of the landslide instability is proposed in the geotechnical reporting by G.A. Nicoll & Associates, Inc. The proposed remediation is also acknowledged and shown in the architectural phasing plans as well. It should be noted, that upon demolition of the existing structures to be removed on the north-end of the property in Phase 1B, and prior to initiating the proposed remediation, additional geotechnical investigation will be conducted on site on the north-end of the property. Improved access following demolition to this area will provide additional geotechnical investigation and will allow for further study, improved understanding and documentation, as well as, design critique of the proposed remediation.

The proposed project will require grading (cut/fill of earth material). The remediation excavation of the area will consist of a total of approximately 101,359 cubic yards of cut-and-fill and will occur in five stages. Each stage involves the removal, backfill and compaction of earth material. Excavation period per stage is anticipated to be between 18 and 22 days for removal, and between 22-30 days for backfill and compaction. The total time of excavation for the project remediation is projected to occur between four to five months. The following provides a description of the remediation earthwork/grading that would occur for each stage as detailed in the geotechnical assessments.

- Stage 1 (Rough Grading) – This stage will result in an export of 18,377 cubic yards of dirt (cyd).
- Stage 2 (Primary Cut) – This stage will result in an export of 29,000 cyd.
- Stage 3 (Slot Cut No. 1) – Earthwork excavation (cut) is made on-site and will result in the export of 9,568 cyd. The remedial earthwork is performed and this site area is returned to the 205' elevation.
- Stage 4 (Slot Cut No. 2) – Earthwork excavation (cut) is made totaling the 44,414 cubic yards of dirt. Approximately, 19,846 cyd of this amount will be exported off-site. The remainder is stockpiled and back filled as necessary on-site.



- **Stage 5 – (Backfill)** The remedial work includes backfilling the area with dirt that was temporarily exported off-site. This remedial work will achieve completion of final grading.

As previously described, existing buildings on the site, with the exception of the existing sanctuary building, will be demolished allowing for improved site access for additional geotechnical investigation on the north-end and to allow for construction to take place in several phases. The first phase of construction consists of development of the proposed Preschool/Administration Building. Following completion of this building, the existing structures on the north-end (administration building, fellowship hall and classrooms) would be demolished so that the proposed remediation site work, inclusive of additional geotechnical investigation, and the Community Life Center (Fellowship Hall/Gymnasium) could be constructed followed by the proposed Christian Education Buildings and then the parking structure. The proposed two-level parking structure will be basically located within the footprint of the existing parking lot. The upper level will be at approximately present street elevation (Crown Valley Parkway). The lower, partially subterranean level will vary in depth below grade, with finished floor elevations ranging from approximately 266 feet at the north end to approximately 252 feet at the south end. The parking structure foundation will be mostly in bedrock of the San Onofre Breccia.

The geotechnical report identified that unstable bedrock and landslide conditions are present beneath the northeast portion of the site (e.g., area near the proposed Christian Education Buildings). The geotechnical report includes recommendations for site remediation in this area of the site including utilizing a deep shear key that removes all of the weak sheared layers beneath the site and replaces the sheared bedrock with compacted fill in addition to a soil cement shear key and caisson/tieback tier retaining wall per the current geotechnical investigation report and proposed remediation. The structures (Christian Education Buildings 1 and 2) would also be supported on spread footings founded in compacted fill soils or bedrock. Additionally, the geotechnical report recommended a structural setback in the northeast corner of the site. Based on the geotechnical investigation including subsurface testing, the study concluded that the site is suitable for the proposed development with implementation of the proposed geotechnical recommendations. Therefore, all potential landslide impacts will be mitigated to a less than significant level with implementation of the proposed recommendations presented in the geotechnical report prepared for the project to date. Additional site access gained following demolition of the existing buildings on the north-end will further finalize the geotechnical remediation currently hampered by inaccessibility.

WHAT WILL BE THE IMPACT OF THIS REMEDIATION ACTIVITY?

- |          |   |
|----------|---|
| MM 3.6-2 | All remediation, grading and construction of the project shall implement the recommendations of the geotechnical report prepared by G.A. Nicoll and Associates, Inc. or approved alternative.                             |
| MM 3.6-3 | Landslide remediation shall be done using the shear key, compacted, soil cement, caisson and tieback system or approved alternative.  |
| MM 3.6-4 | Final Design of the landslide remediation system, including caisson and tieback system, shall include any additional geotechnical investigation and shall be submitted to the City of Dana Point for review and approval. |

GO AHEAD IS BEING GIVEN TO A PROJECT TO BE ENGINEERED AFTER THE FACT?

**b) Result in substantial soil erosion or the loss of topsoil? (*Less Than Significant Impact With Mitigation Incorporated*)**

The site has been previously graded in conjunction with the existing church and parking area. However, the proposed project will require grading (cut/fill) in relation to the construction of the buildings and parking structure. The Public Safety Element of the General Plan identifies that Dana Point's most significant geologic hazards are located within its coastal zone. The coastal zone area has been divided into six subunits for analysis and planning purposes where geologic hazards were evaluated as part of the Coastal Erosion Technical Report and the Public Safety Element Technical Report (part of the General Plan program). The subunits of the coastal zone are shown in Figure PS-1 of the General Plan. The closest subunit to the project site is the Monarch Bay coastal bluff top areas located on the south side of Pacific Coast Highway. These subunits possess significant known geologic hazards with particular attention to coastal soil erosion. The project site is not located in any of the designated coastal erosion areas. However, the geotechnical report prepared for the proposed project includes recommendations for soil erosion in relation to grading and construction of the project. With implementation of recommended mitigation, no significant impacts to soil erosion or the loss of topsoil will result due to the project.

MM 3.6-5 During all construction activities, the project will comply with the current City's erosion control regulations and all applicable requirements of the NPDES permit.

MM 3.6-6 Each project phase design shall include an approved landscape plan and approved Water Quality Management Plan (WQMP) to ensure permanent erosion control.

**c) Be located on a geologic unit or soil that is unstable, or that would become unstable as a result of the project and potentially result in on or off-site landslide, lateral spreading, subsidence, liquefaction or collapse? (*Less Than Significant Impact With Mitigation Incorporated*)**

See response to 3.6.a)iv) above and recommended mitigation. It is not anticipated that significant impacts associated with geology and soils will occur as a result of the implementation of the mitigation measures recommended above (i.e., MM 3.6-1 through MM 3.6-7). Areas identified by the geotechnical report being affected by landslides shall be addressed through the implementation of Mitigation Measures MM 3.6-5 and MM 3.6-6. Lateral spreading and liquefaction do not have any impact as previously stated in Section 3.6(a)(iii).

MM 3.6-7 Prior to the issuance of a grading permit for a phase, a final geotechnical study addressing the phase shall be submitted for review and approval by the City.

**d) Would the project Be located on expansive soil, as defined in Table 18-1-B of the Uniform Building Code (1994), creating substantial risks to life or property? (*Less Than Significant Impact*)**

Compliance with the design and building requirements prescribed in the California Building Code and recommendations of the geotechnical reports prepared by G.A. Nicoll and Associates, Inc. will ensure that no significant impacts relative to this topic are anticipated as a result of the implementation of the project.

### 3.9 Land Use and Planning

The proposed project will not result in any significant impacts relative to land use and planning. The project site is developed with an existing church. The existing property use and proposed project are consistent with the City's General Plan land use designation and zoning of the site, which is Community Facilities. Since the site is already developed with existing church facilities and uses, the project does not physically divide an established community. All proposed church facilities (Administration/Pre-School Building, Christian Education Buildings, Community Life Center, and parking structure) are proposed to be constructed within the South Shores Church property. Additionally, the project has been designed to meet the City's zoning development regulations, including building height, setbacks of structures to property lines, and parking requirements. The proposed project is not subject to any applicable habitat conservation plan or Natural Community Conservation Plan.

#### LARGER FACILITIES = IMPROVED FACILITIES?

**a) Would the project physically divide an established community? (*No Impact*)**

The project site is currently developed with an existing church. The project would demolish all of the buildings on site except for the sanctuary and provide improved facilities to replace those demolished as well as additional parking. Development of the proposed South Shores Church Master Plan project will not physically divide an established community because of proposed uses are to be constructed within the existing church property; therefore no impacts relative to this topic are anticipated.

**b) Would the project conflict with any applicable land use plan, policy, or regulation of an agency with jurisdiction over the project (including, but not limited to the general plan, specific plan, local coastal program, or zoning ordinance) adopted for the purpose of avoiding or mitigating an environmental effect? (*No Impact*)**

THE NEW PROJECT IS NOT A CHURCH

The General Plan land use designation and zoning of the site are Community Facilities (Figure PF-2 of the General Plan). This land use designation allows for a variety of uses including churches. The site is currently developed with a church. The proposed South Shores Church Master Plan project is consistent with these designations. The project site is also located within the Coastal Zone boundary. However, the property is located inland from Pacific Coast Highway. The proposed project design complies with the requirements pertaining to building heights and setbacks. The project has also provided a design for the parking structure which proposes that one-level is below grade and as a result preserves the views across the church property towards the golf course and ocean. The proposed project will provide needed improved facilities at the church. The site is located in a developed area and utilities and services are already provided to the property. The existing site conditions and proposed development has been subject to a comprehensive evaluation (e.g., air quality, geology/soils, hydrology/drainage, and noise). The project has been designed to reduce any potential impacts relative to applicable land use plan, policies, or regulations to a level of less than significant. The proposed project is consistent with the City's General Plan and Land Use Regulations as well as compatible with surrounding land uses. It is not anticipated that the proposed project will result in significant impacts relative to land use.

### 3.11 Noise

A noise assessment evaluating the project was prepared by Mestre Greve Associates (refer to Appendix B). The noise study was prepared in April 2006 and subsequently updated in June 2008 and October 2008 to assess noise in relation to additional geotechnical evaluations and recommendations for the project. The noise study evaluated existing conditions, proposed project construction activities, and future noise conditions that would occur following completion of the project. The proposed project will result in short-term noise impacts associated with construction activities including grading, construction traffic, and demolition of existing uses (except for the sanctuary) and construction of the site improvements (structures, concrete/asphalt, parking structure). The project construction activities will comply with the City of Dana Point's Noise Ordinance during construction activities and following project completion. The project is designed to meet the exterior and interior noise standards of the City of Dana Point. Mitigation is recommended during project construction activities requiring compliance with the Noise Ordinance (identifying allowable hours of construction and no construction on Sundays or Federal holidays). The project will comply with applicable exterior and interior noise standards. Therefore, the project will not result in any significant impacts to noise.

- a) **Would the project result in exposure of persons to or generation of noise levels in excess of standards established in the local general plan or noise ordinance, or applicable standards of other agencies? (*Less Than Significant With Mitigation Incorporated*)**

#### Noise Ordinance

The Dana Point Noise Ordinance (Chapter 11.10 Noise Control) establishes exterior and interior noise standards for noise generated on private property affecting a neighbor. Table 3-13 presents the City of Dana Point's Noise Ordinance standards. The noise ordinance is designed to control unnecessary, excessive and annoying sounds from sources such as parking lots and other stationary sources at the residential property line. The noise ordinance requirements cannot be applied to mobile noise sources such as heavy trucks when traveling on public roadways. Federal and State laws preempt control of the mobile noise sources on public roads. However, the requirements can be applied to vehicles traveling on public property.

The City of Dana Point exterior and interior noise criteria are given in terms L% noise levels. The noise levels specified are those that are not to be exceeded at a residential property from noise generated at a neighbor property. Noise levels are to be measured with A-weighting and a slow time response. Greater noise levels are permitted during the day (7:00 a.m. to 10:00 p.m.) as compared to the nighttime period (10:00 p.m. to 7:00 a.m.).

WHAT ABOUT AN INCREASE IN NOISE LEVEL 18 HOURS PER DAY?

Table 3-13 - City Of Dana Point Noise Ordinance Standards

Maximum Noise Exposure	Noise Metric	Noise Level Not To Be Exceeded	
		7:00 a.m. to 10:00 p.m. (daytime)	10:00 p.m. to 7:00 a.m. (nighttime)
Zone 1 - All residential			
EXTERIOR NOISE STANDARDS			
30 Minutes/Hour	L <sub>50</sub>	55 dBA	50 dBA
15 Minutes/Hour	L <sub>25</sub>	60 dBA	55 dBA
5 Minutes/Hour	L <sub>5</sub>	65 dBA	60 dBA
1 Minutes/Hour	L <sub>1</sub>	70 dBA	65 dBA
Anytime	L <sub>max</sub>	75 dBA	70 dBA
INTERIOR NOISE STANDARDS			
5 Minutes/Hour	L <sub>5</sub>	55 dBA	45 dBA
1 Minutes/Hour	L <sub>1</sub>	60 dBA	50 dBA
Anytime	L <sub>max</sub>	65 dBA	55 dBA

Note: In the event the ambient noise level exceeds any of the noise limit categories above, the cumulative period applicable to said category shall be increased to reflect said ambient noise level.

### Noise Element

The City of Dana Point specifies outdoor and indoor noise limits for various land uses impacted by transportation noise sources. The noise limits specified in the City's Noise Element are expressed in terms of the Community Noise Equivalent Level (CNEL). The proposed project consists of the expansion of the existing church/preschool facilities including new Christian Education buildings, an Administration/Pre-School Building, a Community Life Center, and a parking structure. The project will involve the demolition of existing structures (with the exception of the sanctuary) to accommodate the new buildings, and a parking structure will be added to the site. The project will provide an additional 46,817 square feet (beyond the existing building square footage that currently exists on-site). The standards state that church/community facility buildings shall not exceed an interior noise standard of 45 CNEL for classroom uses, as well as a 50 CNEL for gymnasium and office uses.

### Existing Roadway Noise Levels

An estimate of highway noise levels in terms of CNEL was computed for the roadways affected by project traffic. The distances to the existing 60, 65 and 70 CNEL contours for the roadways in the vicinity of the proposed project site are given in Table 3-14. These represent the distance from the centerline of the road to the contour value shown. The CNEL at 100 feet from the roadway centerline is also presented. The values given in table represent existing noise levels and do not take into account the effect of any existing noise barriers or topography that may affect ambient noise levels.

Table 3-14 - Modeled Existing Roadway Traffic Noise Levels

Roadway Segment	CNEL Level @ 100' †	Distance To CNEL Contour from Centerline of Roadway (feet)		
		70 CNEL	65 CNEL	60 CNEL
<b>CROWN VALLEY PARKWAY</b>				
North of Project site	66.0	54	116	251
South of Project site	65.7	51	111	239
<b>SEA ISLAND DRIVE</b>				
West of Crown Valley Parkway	54.9	RW	RW	46

† From Centerline of Roadway  
RW = Roadway

The above table shows that noise levels in the areas immediate adjacent to Crown Valley Parkway are substantial. The noise levels along the roadway are in excess of 70 CNEL. Sea Island Drive experiences low level of traffic and hence low levels of noise. The noise levels along this roadway are approximately 60 CNEL. SO WE'RE GOING TO HAVE TO SUFFER CROWN VALLEY

LEVELS OF NOISE  
Long-term (i.e., operational) noise impacts include impacts on surrounding land uses generated by the proposed project and those impacts which occur at the proposed project site but are generated off-site, which affect the project.

Long-term off-site impacts from traffic noise are measured against two criteria. Both criteria must be met for a significant impact to be identified. First, project traffic must cause a noise level increase greater than 3dB on a roadway segment adjacent to a noise sensitive land use. Second the future noise level (e.g. with development of the project) must exceed the criteria level for the noise sensitive land use. The noise study used the criteria level of 65 CNEL for residential land uses. In community noise assessment, changes in noise levels greater than 3 dB are often identified as significant, while changes less than 1 dB will not be discernible to local residents. In the range of 1 to 3 dB, residents who are very sensitive to noise may perceive a slight change. Long-term on site impacts are measured against the noise level limits given in the City of Dana Point Noise Element standards. The standards applicable to the project are a 45 CNEL interior standard for classrooms, and a 50 CNEL interior standard for gymnasium and office uses.

### Traffic Noise

Table 3-15 shows the incremental noise level increases due to traffic on roadways in the vicinity of the project. The first column presents the roadway segments analyzed. The second column shows the increases in traffic noise CNEL levels over existing conditions due to all projected growth in the area. This includes general traffic volume growth as well as additional traffic from currently approved projects (not yet built or under construction) in Dana Point. The final column shows the contribution of the increase in noise due to the proposed South Shores Church Master Plan project (if approved and built).

Table 3-15 - Traffic Noise CNEL Level Increases

Roadway Segment	Project Contribution Over Existing	Cumulative Noise Level Increase Over Existing
Crown Valley Parkway		
North of Project site	0.1 dBA	1.1 dBA
South of Project site	0.0 dBA	1.1 dBA
SEA ISLAND DRIVE		
West of Crown Valley Parkway	0.0 dBA	1.0 dBA

Table 3-15 shows that the greatest noise increases due to all traffic growth are along Crown Valley Parkway and Sea Island Drive with increases up to 1.1 dB. Of the cumulative increase in noise, the project-related traffic contributes only 0.1 dBA. This increase is not substantial. The noise study prepared by Mestre Greve Associates, Inc. concluded that there are no significant cumulative traffic noise impacts. NO NOISE LEVEL IMPACT STUDIES ON THE EAST SIDE OF THE

PROJECT WHERE ALL THE NOISE IS DIRECTED  
 The traffic associated with the project is not projected to increase traffic noise levels by, at most, 0.1 dB. This is less than the 3 dB threshold and will not be perceptible to residents. The noise study concluded that the project will not result in a significant noise impact.

The distances to the future 60, 65 and 70 CNEL contours with the proposed project for the roadways in the vicinity of the proposed project site are presented in Table 3-16. These represent the distance from the centerline of the road to the contour value shown. The CNEL at 100 feet from the roadway centerline is also presented. The contours do not take into account the effect of any noise barriers or topography that may affect ambient noise levels.

PLAYGROUNDS, PARTIES WEDDINGS WILL GENERATE MORE NOISE THAN TRAFFIC

Table 3-16 - Future (Year 2020) With Proposed Project Traffic Noise Levels

Roadway Segment	CNEL @ 100' †	Distance To CNEL Contour from Centerline of Roadway (feet)		
		70 CNEL	65 CNEL	60 CNEL
Crown Valley Parkway				
North of Project site	67.1	64	138	297
South of Project site	66.8	61	131	283
SEA ISLAND DRIVE				
West of Crown Valley Parkway	55.9	RW	RW	53

RW- Noise contour falls within roadway right-of-way  
 † From Roadway Centerline

The noise levels reflected in Table 3-16 reveal that areas along Crown Valley Parkway will experience traffic noise levels greater than 70 CNEL. Noise levels along Sea Island Drive will be in excess of 60 CNEL but less than 65 CNEL. The interior noise standards applicable to the project include 45 dBA CNEL for classrooms, and 50 dBA CNEL for gymnasium and office areas. The proposed Community Life Center building adjacent to Crown Valley Parkway will experience traffic noise levels in excess of 65 dBA CNEL, which will require at least a 20 dB exterior-to-interior noise

reduction. As a result, a detailed noise study will be required to show compliance with indoor noise standard for the Community Life Center prior to issuance of a building permit.

### Parking Structure

Onsite activities that could potentially result in off-site noise impacts are from the new two-level parking structure located adjacent to Crown Valley Parkway. The adjacent residential areas are located along the south boundary and to the west along Crown Valley Parkway.

The noise study identified that the traffic associated with parking lots is not of sufficient volume to exceed community noise standards that are based on a time averaged scale such as the CNEL or Leq scale. However, the instantaneous maximum sound levels generated by car door slamming, engine start-up, and car pass-bys can be annoying to nearby residents. Tire squeal may also be a problem depending on the type of parking surface. Estimates of the maximum noise levels associated with some parking lot activities are presented below and are based on limited measurements conducted by Mestre Greve Associates (Table 3-17). The noise levels presented are for a distance of 50 feet from the source, and are the maximum noise level generated. A range is given to reflect the variability of noise generated by various automobile types and driving styles.

Table 3-17 - Maximum Noise Levels Generated by Parking Lots (dBA at 50 feet)

Event	Lmax
Door Slam	60 to 70
Car Alarm Activation	65 to 70
Engine Start-up	60 to 70
Car Pass-by	55 to 70

The nearest parking spaces inside the new parking structure are located approximately 50 feet from the existing residential area adjacent to the south boundary. The maximum noise levels anticipated at these nearest homes from the parking structure are approximately 70 dBA. Therefore, parking structure noise levels are below the City's daytime Noise Ordinance limit of 75 dBA. Further, the proposed parking structure is at the same location as the existing parking lot. While the project may result in more vehicles using the parking structure, it will not substantially increase the noise levels generated within the parking structure. Therefore, the noise study concluded that the parking lot activity will not result in a significant noise impact.

### Community Life Center Activities

The proposed Community Life Center located adjacent to Crown Valley Parkway will include an indoor fellowship hall/gymnasium and a racquet ball court, and classrooms. It is anticipated that the operation hours of the Community Life Center will be between the daytime hours of 7:00 a.m. to 10:00 p.m., and as a result, the project will need to comply with the daytime noise ordinance standards of 55 dBA (L50) and 75 dBA (Lmax). Since all activities associated with the Community Life Center will occur indoors, the noise study concluded that the project will not have a significant



architectural plans show the proposed new enclosure adjacent to the Community Life Center building and the location of the other unit in the lower level of the parking structure as previously described.

These units could operate continuous during any hour in the daytime period for cooling needs. As cited, the noise level generated by these units cannot exceed 55dBA (L50) at the nearest outdoor residential living areas and 55dBA (L8.3) inside the nearest homes, per the Noise Ordinance Daytime Period (7:00 a.m. - 10:00 p.m.). The aforementioned visual and acoustic enclosures proposed, inclusive of resilient flaps around gaps in door openings or the like, will facilitate to affectively reduce noise generated by the units and reduce flanking noise as well, thereby reducing mechanical noise in the surrounding area. The model units proposed also incorporate noise mufflers both at the air inlet and at the top. The average noise level generated, taking into account the mufflers, is estimated to be 50dBA at 50 feet, without the mitigating effects of the masonry enclosures. With the noise mufflers, the condensing unit noise level complied with the daytime exterior standard of 55dBA. Indoor noise levels at the nearest residential unit were 43dBA based on a 12 dB outdoor-to-indoor noise attenuation with windows open; which is lower than the allowable 55dBA interior daytime standard. With the revised location of the unit to the lower level of the parking structure as previously described, potential impacts have been even further reduced, improving conditions to insure that there will be no significant impacts to the nearest homes; therefore, no mitigation measures are required.

MM 3.11-1 Prior to the issuance of a building permit for the Community Life Center, an acoustical engineer shall evaluate the detailed building design for noise attenuation measures to ensure that the interior noise levels of the building comply with applicable City noise regulations.

**b) Would the project result in exposure of persons to or generation of excessive groundborne vibration or groundborne noise levels? (*Less Than Significant Impact*)**

It is unlikely that any activities occurring as a result of project implementation will expose the area to excessive groundborne vibration or groundborne noise levels. As indicated above, potential noise impacts would result from typical construction activities, including grading necessary to excavate the site for subterranean parking and structural footings for the proposed structures. However, it is not anticipated that unusual grading or construction techniques (e.g., blasting) would be anticipated that would cause excessive groundborne vibration or noise. Further, no use proposed on the site would result in such impacts. Therefore, no significant groundborne vibration or noise impacts are anticipated.

**c) Would the project result in a substantial permanent increase in ambient noise levels in the project vicinity above levels existing without the project? (*Less Than Significant Impact*)**

As previously indicated, project implementation will result in an increase in vehicular traffic which, when added to future traffic on Crown Valley Parkway and Sea Island Drive, will result in a small incremental increase in noise levels along those roadways; however, the increase in noise would be less than significant. Other operational noise levels were also determined to be less than significant (refer to Section 3.11.a).

architectural plans show the proposed new enclosure adjacent to the Community Life Center building and the location of the other unit in the lower level of the parking structure as previously described.

These units could operate continuous during any hour in the daytime period for cooling needs. As cited, the noise level generated by these units cannot exceed 55dBA (L50) at the nearest outdoor residential living areas and 55dBA (L8.3) inside the nearest homes, per the Noise Ordinance Daytime Period (7:00 a.m. - 10:00 p.m.). The aforementioned visual and acoustic enclosures proposed, inclusive of resilient flaps around gaps in door openings or the like, will facilitate to affectively reduce noise generated by the units and reduce flanking noise as well, thereby reducing mechanical noise in the surrounding area. The model units proposed also incorporate noise mufflers both at the air inlet and at the top. The average noise level generated, taking into account the mufflers, is estimated to be 50dBA at 50 feet, without the mitigating effects of the masonry enclosures. With the noise mufflers, the condensing unit noise level complied with the daytime exterior standard of 55dBA. Indoor noise levels at the nearest residential unit were 43dBA based on a 12 dB outdoor-to-indoor noise attenuation with windows open; which is lower than the allowable 55dBA interior daytime standard. With the revised location of the unit to the lower level of the parking structure as previously described, potential impacts have been even further reduced, improving conditions to insure that there will be no significant impacts to the nearest homes; therefore, no mitigation measures are required.

MM 3.11-1 Prior to the issuance of a building permit for the Community Life Center, an acoustical engineer shall evaluate the detailed building design for noise attenuation measures to ensure that the interior noise levels of the building comply with applicable City noise regulations.

**b) Would the project result in exposure of persons to or generation of excessive groundborne vibration or groundborne noise levels? (*Less Than Significant Impact*)**

It is unlikely that any activities occurring as a result of project implementation will expose the area to excessive groundborne vibration or groundborne noise levels. As indicated above, potential noise impacts would result from typical construction activities, including grading necessary to excavate the site for subterranean parking and structural footings for the proposed structures. However, it is not anticipated that unusual grading or construction techniques (e.g., blasting) would be anticipated that would cause excessive groundborne vibration or noise. Further, no use proposed on the site would result in such impacts. Therefore, no significant groundborne vibration or noise impacts are anticipated.

**c) Would the project result in a substantial permanent increase in ambient noise levels in the project vicinity above levels existing without the project? (*Less Than Significant Impact*)**

As previously indicated, project implementation will result in an increase in vehicular traffic which, when added to future traffic on Crown Valley Parkway and Sea Island Drive, will result in a small incremental increase in noise levels along those roadways; however, the increase in noise would be less than significant. Other operational noise levels were also determined to be less than significant (refer to Section 3.11.a).

- d) **Would the project result in a substantial temporary or periodic increase in ambient noise levels in the project vicinity above levels existing without the project? (*Less Than Significant Impact With Mitigation Incorporated*)**

#### **Construction Noise (Short-Term Impacts)**

Construction of the project includes demolition of some existing buildings, and grading associated with the construction of the parking structure. In general, site preparation, demolition and grading will generate the highest levels of noise during construction. The construction of the proposed project including demolition and/or grading will occur in five main phases. The first construction phase is projected to start in late 2009. None of these phases will occur simultaneously. That is, one phase will be completed before the next phase is started.

Construction noise, generally, represents a short-term impact on ambient noise levels. Noise generated by construction equipment and construction activities can reach high levels. The noise study prepared by Mestre Greve Associates noted that with increased distance the noise levels decrease. For example, at twice the distance (i.e., 100 feet) the noise levels will be 6 dB lower than those that would occur at 50 feet. At 4 times the distance (i.e., 200 feet), the noise levels will be 12 dB lower. At 500 feet, the noise levels are 20 dB lower than that experienced at 50 feet. The discussion that follows summarizes the anticipated construction noise levels anticipated during each phase of the proposed project.

#### **Phase 1A-Construct a New Preschool/Administration Building**

Phase 1A consists of the grading and construction of a new Administration/Pre-School building approximately 15,115 square feet in size. The nearest homes are located directly adjacent to the south boundary of the project, and could be located as close as 10 feet from the construction area. It is possible that as heavy equipment passes adjacent to these homes noise levels could reach as high as 110 dBA for very short periods. However, most of the project site is located more than 100 feet from these homes. Long-term average noise levels would be in the 80 to 90 dBA range during construction.

#### **Phase 1B-Demolish Existing Buildings and Excavation of North End of Site**

Phase 1B involves the demolition of three existing buildings: preschool, administration and fellowship hall, and the chapel. The nearest homes are located west of Crown Valley Parkway. Demolition activities may occur approximately 100 feet of the nearest homes. The peak noise level from the demolition equipment could be approximately 91 dBA at the nearest residential area. Long-term average noise levels would be in the 56 to 81 dBA range during construction.

Demolition debris will be trucked off site to remote locations. These trucks will generate noise along public roadways. The trucks are expected to travel on Crown Valley Parkway, entering and exiting the site from the project's main entrance. This would increase existing noise levels on Crown Valley Parkway due to the addition of the trucks by 0.01 dBA. The noise study concluded that the increase is not significant.

This phase also includes excavation (cut/fill) of the north end of the site (near Christian Education Buildings 1 and 2). The excavation of the area will consist of a total of approximately 101,359 cubic yards of cut-and-fill and occur in five stages. Each stage involves the removal, backfill and compaction of earth material. Excavation period per stage is anticipated to be between 18 and 22 days for removal, and between 22 and 30 days for backfill and compaction. The total time of excavation is projected to occur between six to seven months. Excavated earth material will be transported off-site (temporarily and will be returned to the site at time of backfilling occurs). A portion of the earth material will remain on-site and will be stored in stockpiles until backfilling takes place. (A detailed description of the excavation and grading is presented in Section 3.6, Geology and Soils).

The nearest homes are located across Crown Valley Parkway to the west of the project site. These homes are estimated to be located approximately 173 feet from the nearest potential construction equipment associated with the grading/excavation operations. Based on this distance, the homes would experience a peak noise level of approximately 84 dBA for very short periods. However, most of the project site is located more than 173 feet from these homes. Short-term average noise levels would be in the 50 to 60 dBA range during the grading/excavation. It should be noted that the existing traffic along Crown Valley Parkway could be louder.

#### **Phase 1C - Construct a New Community Life Building (Fellowship Hall/Gymnasium)**

Phase 1C consists of the grading and construction of a new Community Life Center building approximately 24,314 square feet in size. The nearest homes located west of Crown Valley Parkway are located approximately 100 feet from the construction area. At this distance, the peak noise level from the construction equipment could be approximately 91 dBA at the nearest homes. Average noise levels would be in the 55 to 78 dBA range during construction.

#### **Phase 2 - Construct New Christian Education Building #1**

Phase 2 includes the grading and construction of a new Christian Education Building #1 approximately 15,399 square feet in size. The nearest homes are located west of Crown Valley Parkway and are located approximately 320 feet from the construction site. The peak noise level from the construction equipment could be approximately 81 dBA at the nearest homes. Average noise levels would be in the 53 to 68 dBA range during construction.

#### **Phase 3 - Construct New Christian Education Building #2**

The second new Christian Education Building #2 is located next to the north side of Building #1 and is approximately 15,456 square feet in size. Therefore, the construction noise levels are similar to Phase 2 for the residential area west of Crown Valley Parkway. The peak noise level from the construction equipment could be approximately 81 dBA at the nearest homes. Average noise levels would be in the 53 to 68 dBA range during construction.

### 3.12 Population and Housing

The proposed project does not include the construction of residential development. The project consists of the demolition of several of the existing church structures and the replacement of these structures with new, updated facilities. In conjunction with the replacement, additional new uses will also be added, including a Community Life Center and two-level parking structure. These new uses will expand the existing church operations. Due to the type of project (expansion of existing church) the project does not induce substantial population growth in the area. The area where the project site is located is already developed with existing residences, roadway, retail, a nearby hotel and a golf course. Additionally, the project will not displace existing housing. The project does not result in any significant impacts to population and housing.

- a) **Would the project induce substantial population growth in an area, either directly (for example, by proposing new homes and businesses) or indirectly (for example, through extension of roads or other infrastructure)? (No Impact)**

The project consists of the replacement of several existing buildings (except for the sanctuary) with new buildings and a parking structure within the property boundaries of an existing church. The project is proposed in response to current and projected church needs relative to facility space and programs. The property is located in an area where infrastructure exists and will serve the site. No significant new or unanticipated significant infrastructure will be required for the project. The project will not induce substantial population growth in the area, either directly or indirectly beyond that already contemplated per the City's General Plan, county and state population/housing projections.

- b) **Would the project displace substantial numbers of existing housing, necessitating the construction of replacement housing elsewhere? (No Impact)**

The project does not involve elimination of any existing housing. The project site is already developed with an existing operational church. Therefore, the project will not displace any existing housing.

- c) **Would the project displace substantial numbers of people, necessitating the construction of replacement housing elsewhere? (No Impact)**

The subject property is developed with an existing church. The proposed development will occur within the existing church property. The proposed project will not have any impacts involving demolition of existing housing necessitating construction of new housing. The project will not result in the displacement of substantial numbers of people and/or housing that would necessitate the construction of replacement housing.

### 3.13 Public Services

The project will involve the demolition of existing facilities within the church property including the existing administration office, fellowship hall, classroom buildings, and youth center. These structures will be replaced with new church buildings. Public services are already being provided to the project area and to the South Shores Church property. The project is designed to meet fire and safety requirements. The project will not result in any significant impacts to public services.

- a) **Would the project result in substantial adverse physical impacts associated with the provision of new or physically altered government facilities, need for new or physically altered government facilities, the construction of which could cause significant environmental impacts, in order to maintain acceptable service ratios, response times or other performance objectives for any of the public services: (*Less Than Significant Impact*)**

Public services are provided to the City of Dana Point and the project site by several public agencies. It is not anticipated that the project would result in substantial adverse impacts to public services since it is located in an area already being serviced by various utility and service entities.

i. **Fire protection? (*Less Than Significant Impact*)**

The Orange County Fire Authority (OCFA) provides fire protection and emergency response services for the City. Response times to the site are dependent on various factors. Response time is generally five minutes or less. Emergency calls receive the quickest response times with alarm calls and non-emergency calls having longer response times respectively. The availability of personnel and extenuating circumstances may further affect response times. The closest fire station to the site is located in the City is on Niguel Road just north of Pacific Coast Highway. The project is located in a developed area, however, open space with landscaped and natural vegetation exist to the east of the church property (e.g. canyon area, Salt Creek and nearby golf course). The project has been designed to meet the requirements of the OCFA including a Fire Master and Fuel Management Plan. The Fire Master Plan and Phasing Plan (OCFA SR#154421) was approved by the OCFA on October 28, 2008. The Fuel Management Plan (OCFA SR#160396) was approved by OCFA on October 23, 2008. Therefore, no significant impacts to fire protection services and/or facilities will occur as a result of project implementation.

ii. **Police protection? (*No Impact*)** EVERY TIME THEY MAKE NOISE THE POLICE

WILL HAVE TO RESPOND  
 Law enforcement services are provided by the Orange County Sheriff's Department (OCSD). The OCSD is a multi-faceted law enforcement agency composed of approximately 4,000 staff members and over 800 reserve personnel. In addition to providing service to the unincorporated areas of Orange County, the OCSD provides contract services to 11 cities within the county including Dana Point.<sup>8</sup> Dana Point Police Services provide 25 full time deputies, 5 sergeants, and five parking control officers. The County-wide service standards and goals for the Sheriff's Department includes: a) response within 5 minutes or less to calls of life or property threatening incidents in progress, and b) response within 20 minutes or less to a non-emergency. The site is already developed with an

<sup>8</sup> <http://www.ocsd.org>

### 3.14 Recreation

The project will have no impact on existing recreational facilities in the City of Dana Point. The project provides a beneficial impact in that opportunities for recreation will be provided on-site. The South Shores Church currently utilizes the Dana Point Community Center for the youth basketball program. The proposed on-site recreation will eliminate the need to utilize the community center, which experiences a significant amount of use and demand by the community. Since the project will provide on-site recreation and the project does not propose any uses that would contribute to an increased use of existing recreational facilities in the City of Dana Point, the project will have no impact on recreation. No mitigation measures are required.

- a) **Would the project increase the use of existing neighborhood and regional parks or other recreational facilities such that substantial physical deterioration of the facility would occur or be accelerated? (No Impact)**

As previously indicated, the proposed project will not generate new residents (or increase the population) and, therefore, it will not create a demand for parks and recreational facilities. The project proposes facilities that will provide recreational amenities on-site, including the Community Life Center (Fellowship Hall/Gymnasium) and the Christian Education Buildings (classroom areas for programs). The project will provide opportunities for a range of programs and functions to serve the needs of the church and community that utilize the church facilities. The project will not result in any potential significant increase in demand of the use of existing recreation facilities; no mitigation measures are required.

- b) **Does the project include recreational facilities or require the construction of or expansion of recreational facilities which might have an adverse physical effect on the environment? Opportunities? (No Impact)**

The project involves the construction of new structures and replacement of existing structures within an existing church campus. In regards to recreational facilities, the project will provide a Community Life Center, which includes a gymnasium (interior sports court for basketball, volleyball and racquetball uses). The project will also provide outdoor areas (playground area for the preschool and church uses) and garden areas. Project implementation would have a potential beneficial impact on recreational facilities because it would provide greater opportunities for recreation on-site compared to that which currently exists. Therefore, the project will not result in any significant impacts to existing public recreation.

property. Other portions of the site also drain to the parking lot and follow the same path to the existing outlet structure. The remainder portions of the site drain towards the existing slopes along the easterly and northeasterly edge of the site. Project implementation will include drainage systems that will collect and deliver storm water to the locations where drainage presently exists on the site. These existing and proposed facilities will be adequate to accommodate the increase in runoff. Therefore, no significant impacts will occur as a result of project implementation.

- d) **Would the project have sufficient water supplies available to serve the project from existing entitlements and resources, or are new or expanded entitlements needed? (*Less Than Significant Impact*)** WHAT ABOUT CONSTRUCTION WATER?

Project implementation will not adversely affect existing water supplies. The project is consistent with the City's General Plan Land Use Element and will not create demands for water that exceed the parameters upon which the water supply and distribution is based. The SCWD owns and maintains facilities in the vicinity of the subject property that serve the existing church. Although the proposed expansion of the existing church will create a demand for potable water, domestic water can be provided from the existing water supply and distribution system, which meets both the existing and proposed fire demands. Project implementation will not require the construction of new water or wastewater treatment facilities. Therefore, it is not anticipated that the project will result in any significant impacts relative to water supplies. HOWEVER WE HAVE A WATER SHORTAGE

- e) **Would the project result in a determination by the wastewater treatment provider, which serves or may serve the project that it has adequate capacity to serve the project's projected demand in addition to the provider's existing commitments? (*Less Than Significant Impact*)**

The SCWD has indicated that it has adequate capacity in the existing treatment facilities to provide sanitary treatment to the increase in raw sewage that will be generated by the proposed project. As previously indicated, the proposed expansion of the existing church facilities is consistent with the City's General Plan Land Use Element and does not proposed any significant growth beyond the City's buildout. Therefore, no significant impacts are anticipated as a result of project implementation.

- f) **Would the project be served by a landfill with sufficient permitted capacity to accommodate the project's solid waste disposal needs? (*Less Than Significant Impact*)**

The proposed project will require demolition of existing structures and therefore would generate construction debris (e.g., wood, glass, asphalt, concrete). Implementation of the proposed project would result in a small incremental increase in solid waste at the site. There are approximately fourteen (14) recycling, construction and demolition debris and green waste processing locations located throughout Orange County. The closest processing locations to the project site include Ewles Materials located in San Juan Capistrano. The Orange County Integrated Waste Management Department (IWMD) owns and operates three landfills. The project site will be served by a solid waste collection service that is contracted for by the City of Dana Point.

The General Plan identifies that the City as required by AB 939 continue to implement waste diversion programs as well as public education programs to reduce the amount of solid waste by 50 percent. Additionally, the City requires that 75 percent of construction demolition material be



- d) **Does the project have environmental effects which will cause substantial adverse effects on human beings, either directly or indirectly? (*Less than Significant Impact with Mitigation Incorporated*)**

There are several impacts identified in the foregoing analysis that require mitigation. Recommended mitigation has been presented in these topical sections (e.g., geology/soils, noise) to reduce all impacts to a less than significant level. Additionally, there are no known substantial adverse effects on human beings that would be caused by the proposed project after mitigation as prescribed. The proposed project is compatible with the land uses in the project area and the environmental evaluation has concluded that no adverse significant environmental impacts will result from the project with the incorporation of mitigation measures (e.g., air quality, geology/soils, hydrology/drainage, noise).

### Environmental Factors Potentially Affected:

The environmental factors checked below would be potentially affected by this project, involving at least one impact that is a "Potentially Significant Impact" as indicated by the checklist on the following pages.

- |  |   |  |
|--|---|--|
| <input checked="" type="checkbox"/> Aesthetics         | <input type="checkbox"/> Hydrology & Water Quality    | <input type="checkbox"/> Utilities & Service Systems                   |
| <input type="checkbox"/> Agriculture Resources         | <input checked="" type="checkbox"/> Land Use Planning | <input type="checkbox"/> Transportation/Circulation                    |
| <input checked="" type="checkbox"/> Air Quality        | <input type="checkbox"/> Mineral Resources            |  |
| <input type="checkbox"/> Biological Resources          | <input checked="" type="checkbox"/> Noise             | <input checked="" type="checkbox"/> Mandatory Findings of Significance |
| <input type="checkbox"/> Cultural Resources            | <input type="checkbox"/> Population & Housing         |  |
| <input checked="" type="checkbox"/> Geology & Soils    | <input type="checkbox"/> Public Services              |  |
| <input type="checkbox"/> Hazards & Hazardous Materials | <input checked="" type="checkbox"/> Recreation        |  |

**Determination** (To be completed by the Lead Agency)

On the basis of this initial evaluation:

I find that the proposed project COULD NOT have a significant effect on the environment, and a NEGATIVE DECLARATION will be prepared.	<input type="checkbox"/>
I find that although the proposed project could have a significant effect on the environment, there will not be a significant effect in this case because revisions in the project have been made by or agreed to by the project proponent. A MITIGATED NEGATIVE DECLARATION will be prepared.	<input checked="" type="checkbox"/>
I find that the proposed project MAY have a significant effect on the environment, and ENVIRONMENTAL IMPACT REPORT is required.	<input type="checkbox"/>
I find that the proposed project MAY have a significant effect(s) on the environment, but at least one effect 1) has been adequately analyzed in an earlier document pursuant to applicable legal standards, and 2) has been addressed by mitigation measures based on the earlier analysis as described on attached sheets, if the effect is a "potentially significant impact" or "potentially significant unless mitigated." An ENVIRONMENTAL IMPACT REPORT is required, but it must analyze only the effects that remain to be addressed.	<input type="checkbox"/>
I find that although the proposed project could have a significant effect on the environment, there WILL NOT be a significant effect in this case because all potentially significant effects (a) have been analyzed adequately in an earlier EIR or NEGATIVE DECLARATION pursuant to applicable standards and (b) have been avoided or mitigated pursuant to that earlier EIR, including revisions or mitigation measures that are imposed upon the proposed project, nothing further is required.	<input type="checkbox"/>

Submitted by: City of Dana Point  
Community Development Department

Prepared by: Hodge & Associates

\_\_\_\_\_  
Cheryle L. Hodge  
Hodge & Associates

\_\_\_\_\_  
date

**City of Dana Point  
Environmental Checklist**

	Potentially Significant Impact	Less Than Significant With Mitigation Incorporated	Less than Significant Impact	No Impact
<b>I. AESTHETICS</b>				
Would the project:				
a) Have a substantial adverse effect on a scenic vista?	<input type="checkbox"/>	<input type="checkbox"/>	<input checked="" type="checkbox"/>	<input type="checkbox"/>
b) Substantially damage scenic resources, including, but not limited to, trees, rock outcroppings, and historic buildings within a state scenic highway?	<input type="checkbox"/>	<input type="checkbox"/>	<input checked="" type="checkbox"/>	<input type="checkbox"/>
c) Substantially degrade the existing visual character or quality of the site and its surroundings?	<input type="checkbox"/>	<input type="checkbox"/>	<input checked="" type="checkbox"/>	<input type="checkbox"/>
d) Create a new source of substantial light or glare which would adversely affect day or nighttime views in the area?	<input type="checkbox"/>	<input type="checkbox"/>	<input checked="" type="checkbox"/>	<input type="checkbox"/>
<b>II. AGRICULTURE RESOURCES</b>				
Would the project:				
a) Convert Prime Farmland, Unique Farmland, or Farmland of Statewide Importance (Farmland), as shown on the maps prepared pursuant to the Farmland Mapping and Monitoring Program of the California Resources Agency, to non-agricultural use?	<input type="checkbox"/>	<input type="checkbox"/>	<input type="checkbox"/>	<input checked="" type="checkbox"/>
b) Conflict with existing zoning for agricultural use, or a Williamson Act contract?	<input type="checkbox"/>	<input type="checkbox"/>	<input type="checkbox"/>	<input checked="" type="checkbox"/>
c) Involve other changes in the existing environment which, due to their location or nature, could result in conversion of Farmland, to non-agricultural use?	<input type="checkbox"/>	<input type="checkbox"/>	<input type="checkbox"/>	<input checked="" type="checkbox"/>
<b>III. AIR QUALITY</b>				
Would the project:				
a) Conflict with or obstruct implementation of the applicable air quality plan?	<input type="checkbox"/>	<input type="checkbox"/>	<input type="checkbox"/>	<input checked="" type="checkbox"/>
b) Violate any air quality standard or contribute to an existing or projected air quality violation?	<input type="checkbox"/>	<input checked="" type="checkbox"/>	<input type="checkbox"/>	<input type="checkbox"/>
c) Result in a cumulatively considerable net increase of any criteria pollutant for which the project region is non-attainment under an applicable federal or state ambient air quality standard (including releasing emissions which exceed quantitative thresholds for ozone precursors)?	<input type="checkbox"/>	<input type="checkbox"/>	<input checked="" type="checkbox"/>	<input type="checkbox"/>
d) Expose sensitive receptors to substantial pollutant concentrations?	<input type="checkbox"/>	<input type="checkbox"/>	<input checked="" type="checkbox"/>	<input type="checkbox"/>
e) Create objectionable odors affecting a substantial number of people?	<input type="checkbox"/>	<input type="checkbox"/>	<input type="checkbox"/>	<input checked="" type="checkbox"/>

	Potentially Significant Impact	Less Than Significant With Mitigation Incorporated	Less than Significant Impact	No Impact
<b>IV. BIOLOGICAL RESOURCES</b>				
Would the project:				
a) Have a substantial adverse effect, either directly or through habitat modifications, on any species identified as a candidate, sensitive, or special status species in local or regional plans, policies, or regulations or by the California Department of Fish and Game or U.S. Fish and Wildlife Service?	<input type="checkbox"/>	<input checked="" type="checkbox"/>	<input type="checkbox"/>	<input type="checkbox"/>
b) Have a substantial adverse effect on any riparian habitat or other sensitive natural community identified in local or regional plans, policies, regulations or by the California Department of Fish and Game or U.S. Fish and Wildlife Service?	<input type="checkbox"/>	<input type="checkbox"/>	<input type="checkbox"/>	<input checked="" type="checkbox"/>
c) Have a substantial adverse effect on federally protected wetlands as defined by Section 404 of the Clean Water Act (including, but not limited to, marsh, vernal pool, coastal, etc.) through direct removal, filling, hydrological interruption, or other means?	<input type="checkbox"/>	<input type="checkbox"/>	<input type="checkbox"/>	<input checked="" type="checkbox"/>
d) Interfere substantially with the movement of any native resident or migratory fish or wildlife species or with established native resident or migratory wildlife corridors, or impeded the use of native wildlife nursery sites?	<input type="checkbox"/>	<input type="checkbox"/>	<input type="checkbox"/>	<input checked="" type="checkbox"/>
e) Conflict with any local policies or ordinances protecting biological resources, such as a tree preservation policy or ordinance?	<input type="checkbox"/>	<input type="checkbox"/>	<input type="checkbox"/>	<input checked="" type="checkbox"/>
f) Conflict with the provisions of an adopted Habitat Conservation Plan, Natural Community Conservation Plan, or other approved local, regional, or state habitat conservation plan?	<input type="checkbox"/>	<input type="checkbox"/>	<input type="checkbox"/>	<input checked="" type="checkbox"/>
<b>V. CULTURAL RESOURCES</b>				
Would the project:				
a) Cause a substantial adverse change in the significance of a historical resource as defined in §15064.5?	<input type="checkbox"/>	<input type="checkbox"/>	<input type="checkbox"/>	<input checked="" type="checkbox"/>
b) Cause a substantial adverse change in the significance of an archaeological resource pursuant to §15064.5?	<input type="checkbox"/>	<input checked="" type="checkbox"/>	<input type="checkbox"/>	<input type="checkbox"/>
c) Directly or indirectly destroy a unique paleontological resource or site or unique geologic feature?	<input type="checkbox"/>	<input checked="" type="checkbox"/>	<input type="checkbox"/>	<input type="checkbox"/>
d) Disturb any human remains, including those interred outside of formal cemeteries?	<input type="checkbox"/>	<input type="checkbox"/>	<input checked="" type="checkbox"/>	<input type="checkbox"/>
<b>VI. GEOLOGY AND SOILS</b>				
Would the project:				
a) Expose people or structures to potential substantial adverse effects, including the risk of loss, injury, or death involving:	<input type="checkbox"/>	<input type="checkbox"/>	<input type="checkbox"/>	<input type="checkbox"/>
i) Rupture of a known earthquake fault, as delineated on the most recent Alquist-Priolo Earthquake Fault Zoning Map issued by the State Geologist for the area or based on other substantial evidence of a known fault? Refer to Division of Mines and Geology Special Publication 42.	<input type="checkbox"/>	<input type="checkbox"/>	<input checked="" type="checkbox"/>	<input type="checkbox"/>
ii) Strong seismic ground shaking?	<input type="checkbox"/>	<input checked="" type="checkbox"/>	<input type="checkbox"/>	<input type="checkbox"/>
iii) Seismic-related ground failure, including liquefaction?	<input type="checkbox"/>	<input type="checkbox"/>	<input checked="" type="checkbox"/>	<input type="checkbox"/>
iv) Landslides?	<input type="checkbox"/>	<input checked="" type="checkbox"/>	<input type="checkbox"/>	<input type="checkbox"/>

Appendix A -  
Environmental Checklist Form

	Potentially Significant Impact	Less Than Significant With Mitigation Incorporated	Less than Significant Impact	No Impact
b) Result in substantial soil erosion or the loss of topsoil?	<input type="checkbox"/>	<input checked="" type="checkbox"/>	<input type="checkbox"/>	<input type="checkbox"/>
c) Be located on a geologic unit or soil that is unstable, or that would become unstable as a result of the project and potentially result in on- or off-site landslide, lateral spreading, subsidence, liquefaction or collapse?	<input type="checkbox"/>	<input checked="" type="checkbox"/>	<input type="checkbox"/>	<input type="checkbox"/>
d) Be located on expansive soil, as defined in Table 18- 1-B of the Uniform Building Code (1994), creating substantial risks to life or property?	<input type="checkbox"/>	<input type="checkbox"/>	<input checked="" type="checkbox"/>	<input type="checkbox"/>
e) Have soils incapable of adequately supporting the use septic tanks or alternative waste water disposal systems where sewers are not available for the disposal of waste water?	<input type="checkbox"/>	<input type="checkbox"/>	<input type="checkbox"/>	<input checked="" type="checkbox"/>
<b>VII. HAZARDS AND HAZARDOUS MATERIALS</b>				
Would the project:				
a) Create a significant hazard to the public or the environment through routine transport, use, or disposal of hazardous materials?	<input type="checkbox"/>	<input type="checkbox"/>	<input type="checkbox"/>	<input checked="" type="checkbox"/>
b) Create a significant hazard to the public or the environment through reasonably foreseeable upset and accident conditions involving the release of hazardous materials into the environment?	<input type="checkbox"/>	<input checked="" type="checkbox"/>	<input type="checkbox"/>	<input type="checkbox"/>
c) Emit hazardous emissions or handle hazardous or acutely hazardous materials, substances, or waste within one-quarter mile of an existing or proposed school?	<input type="checkbox"/>	<input checked="" type="checkbox"/>	<input type="checkbox"/>	<input type="checkbox"/>
d) Be located on a site which is included on a list of hazardous materials sites which complied pursuant to Government Code Section 65962.5 and, as a result, would it create a significant hazard to the public or the environment?	<input type="checkbox"/>	<input type="checkbox"/>	<input type="checkbox"/>	<input checked="" type="checkbox"/>
e) For a project within an airport land use plan or, where such a plan has not been adopted, within two miles of a public airport or public use airport, would the project result in a safety hazard for people residing or working in the project area?	<input type="checkbox"/>	<input type="checkbox"/>	<input type="checkbox"/>	<input checked="" type="checkbox"/>
f) For a project within the vicinity of a private airstrip, would the project result in a safety hazard for people residing or working in the project area?	<input type="checkbox"/>	<input type="checkbox"/>	<input type="checkbox"/>	<input checked="" type="checkbox"/>
g) Impair implementation of or physically interfere with an adopted emergency response plan or emergency evacuation plan?	<input type="checkbox"/>	<input type="checkbox"/>	<input type="checkbox"/>	<input checked="" type="checkbox"/>
h) Expose people or structures to a significant risk of loss, injury or death involving wildland fires, including where wildlands are adjacent to urbanized areas or where residences are intermixed with wildlands?	<input type="checkbox"/>	<input type="checkbox"/>	<input checked="" type="checkbox"/>	<input type="checkbox"/>
<b>VIII. HYDROLOGY AND WATER QUALITY</b>				
Would the project:				
a) Violate any water quality standards or waste discharge requirements?	<input type="checkbox"/>	<input checked="" type="checkbox"/>	<input type="checkbox"/>	<input type="checkbox"/>

Appendix A -  
Environmental Checklist Form

	Potentially Significant Impact	Less Than Significant With Mitigation Incorporated	Less than Significant Impact	No Impact
s) Have a potentially significant adverse impact on groundwater quality?	<input type="checkbox"/>	<input checked="" type="checkbox"/>	<input type="checkbox"/>	<input type="checkbox"/>
t) Cause or contribute to an exceedance of applicable surface or groundwater receiving water quality objectives or degradation of beneficial uses?	<input type="checkbox"/>	<input checked="" type="checkbox"/>	<input type="checkbox"/>	<input type="checkbox"/>
u) Impact aquatic, wetland, or riparian habitat?	<input type="checkbox"/>	<input checked="" type="checkbox"/>	<input type="checkbox"/>	<input type="checkbox"/>
<b>IX. LAND USE AND PLANNING</b>				
Would the proposal:				
a) Physically divide an established community?	<input type="checkbox"/>	<input type="checkbox"/>	<input type="checkbox"/>	<input checked="" type="checkbox"/>
b) Conflict with any applicable land use plan, policy, or regulation of an agency with jurisdiction over the project (including, but not limited to the general plan, specific plan, local coastal program, or zoning ordinance) adopted for the purpose of avoiding or mitigating an environmental effect?	<input type="checkbox"/>	<input type="checkbox"/>	<input type="checkbox"/>	<input checked="" type="checkbox"/>
c) Conflict with any applicable habitat conservation plan or natural community conservation plan?	<input type="checkbox"/>	<input type="checkbox"/>	<input type="checkbox"/>	<input checked="" type="checkbox"/>
<b>X. MINERAL RESOURCES</b>				
Would the project:				
a) Result in the loss of availability of a known mineral resource that would be of value to the region and the residents of the state?	<input type="checkbox"/>	<input type="checkbox"/>	<input type="checkbox"/>	<input checked="" type="checkbox"/>
b) Result in the loss of availability of a locally-important mineral resource recovery site delineated on a local general plan, specific plan, or other land use plan?	<input type="checkbox"/>	<input type="checkbox"/>	<input type="checkbox"/>	<input checked="" type="checkbox"/>
<b>XI. NOISE</b>				
Would the project result in:				
a) Exposure of persons to or generation of noise levels in excess of standards established in the local general plan or noise ordinance, or applicable standards of other agencies?	<input type="checkbox"/>	<input checked="" type="checkbox"/>	<input type="checkbox"/>	<input type="checkbox"/>
b) Exposure of persons to or generation of excessive groundborne vibration or groundborne noise levels?	<input type="checkbox"/>	<input type="checkbox"/>	<input checked="" type="checkbox"/>	<input type="checkbox"/>
c) A substantial permanent increase in ambient noise levels in the project vicinity above levels existing without the project?	<input type="checkbox"/>	<input type="checkbox"/>	<input checked="" type="checkbox"/>	<input type="checkbox"/>
d) A substantial temporary or periodic increase in ambient noise levels in the project vicinity above levels existing without the project?	<input type="checkbox"/>	<input checked="" type="checkbox"/>	<input type="checkbox"/>	<input type="checkbox"/>
e) For a project located within an airport land use land use plan or, where such a plan has not been adopted, within two miles of a public airport or public use airport, would the project expose people residing or working in the project area to excessive noise levels?	<input type="checkbox"/>	<input type="checkbox"/>	<input type="checkbox"/>	<input checked="" type="checkbox"/>
f) For a project within the vicinity of a private airstrip, would the project expose people residing or working in the project area to excessive noise levels?	<input type="checkbox"/>	<input type="checkbox"/>	<input type="checkbox"/>	<input checked="" type="checkbox"/>

	Potentially Significant Impact	Less Than Significant With Mitigation Incorporated	Less than Significant Impact	No Impact
<b>XII. POPULATION AND HOUSING</b>				
Would the project:				
a) Induce substantial population growth in an area, either directly (for example, by proposing new homes and businesses) or indirectly (for example, through extension of roads or other infrastructure)?	<input type="checkbox"/>	<input type="checkbox"/>	<input type="checkbox"/>	<input checked="" type="checkbox"/>
b) Displace substantial numbers of existing housing, necessitating the construction of replacement housing elsewhere?	<input type="checkbox"/>	<input type="checkbox"/>	<input type="checkbox"/>	<input checked="" type="checkbox"/>
c) Displace substantial numbers of people, necessitating the construction of replacement housing elsewhere?	<input type="checkbox"/>	<input type="checkbox"/>	<input type="checkbox"/>	<input checked="" type="checkbox"/>
<b>XIII. PUBLIC SERVICES</b>				
a) Would the project result in substantial adverse physical impacts associated with the provision of new or physically altered government facilities, need for new or physically altered government facilities, the construction of which could cause significant environmental impacts, in order to maintain acceptable service ratios, response times or other performance objectives for any of the public services:	<input type="checkbox"/>	<input type="checkbox"/>	<input checked="" type="checkbox"/>	<input type="checkbox"/>
i. Fire protection?	<input type="checkbox"/>	<input type="checkbox"/>	<input checked="" type="checkbox"/>	<input type="checkbox"/>
ii. Police protection?	<input type="checkbox"/>	<input type="checkbox"/>	<input type="checkbox"/>	<input checked="" type="checkbox"/>
iii. Schools?	<input type="checkbox"/>	<input type="checkbox"/>	<input type="checkbox"/>	<input checked="" type="checkbox"/>
iv. Parks?	<input type="checkbox"/>	<input type="checkbox"/>	<input type="checkbox"/>	<input checked="" type="checkbox"/>
v. Other public facilities?	<input type="checkbox"/>	<input type="checkbox"/>	<input type="checkbox"/>	<input checked="" type="checkbox"/>
<b>XIV. RECREATION</b>				
a) Would the project increase the use of existing neighborhood and regional parks or other recreational facilities such that substantial physical deterioration of the facility would occur or be accelerated?	<input type="checkbox"/>	<input type="checkbox"/>	<input type="checkbox"/>	<input checked="" type="checkbox"/>
b) Does the project include recreational facilities or require the construction of or expansion of recreational facilities which might have an adverse physical effect on the environment?	<input type="checkbox"/>	<input type="checkbox"/>	<input type="checkbox"/>	<input checked="" type="checkbox"/>
<b>XV. TRANSPORTATION/TRAFFIC</b>				
Would the project:				
a) Cause an increase in traffic which is substantial in relation to the existing traffic load and capacity of the street system (i.e., result in a substantial increase in either the number of vehicle trips, the volume to capacity ratio on roads, or congestion at intersections)?	<input type="checkbox"/>	<input type="checkbox"/>	<input checked="" type="checkbox"/>	<input type="checkbox"/>
b) Exceed either individually or cumulatively, a level of service standard established by the county congestion management agency for designated roads or highways?	<input type="checkbox"/>	<input type="checkbox"/>	<input checked="" type="checkbox"/>	<input type="checkbox"/>
c) Result in a change in air traffic patterns, including either an increase in traffic levels or a change in location that results in substantial safety risks?	<input type="checkbox"/>	<input type="checkbox"/>	<input type="checkbox"/>	<input checked="" type="checkbox"/>
d) Substantially increase hazards due to a design feature (e.g., sharp curves or dangerous intersections) or incompatible uses (e.g., farm equipment)?	<input type="checkbox"/>	<input type="checkbox"/>	<input type="checkbox"/>	<input checked="" type="checkbox"/>
e) Result in inadequate emergency access?	<input type="checkbox"/>	<input type="checkbox"/>	<input type="checkbox"/>	<input checked="" type="checkbox"/>



	Potentially Significant Impact	Less Than Significant With Mitigation Incorporated	Less than Significant Impact	No Impact
f) Result in inadequate parking capacity?	<input type="checkbox"/>	<input checked="" type="checkbox"/>	<input type="checkbox"/>	<input type="checkbox"/>
g) Conflict with adopted policies, plans, or programs supporting alternative transportation (e.g., bus turnouts, bicycle racks)?	<input type="checkbox"/>	<input type="checkbox"/>	<input type="checkbox"/>	<input checked="" type="checkbox"/>
<b>XVI. UTILITIES &amp; SERVICE SYSTEMS</b>				
Would the project:				
a) Exceed wastewater treatment requirements of the applicable Regional Water Quality Control Board?	<input type="checkbox"/>	<input type="checkbox"/>	<input checked="" type="checkbox"/>	<input type="checkbox"/>
b) Require or result in the construction of new water or wastewater treatment facilities or expansion of existing facilities, the construction of which could cause significant environmental effects?	<input type="checkbox"/>	<input type="checkbox"/>	<input checked="" type="checkbox"/>	<input type="checkbox"/>
c) Require or result in the construction of new storm water drainage facilities or expansion of existing facilities, the construction of which could cause significant environmental effects?	<input type="checkbox"/>	<input type="checkbox"/>	<input checked="" type="checkbox"/>	<input type="checkbox"/>
d) Have sufficient water supplies available to serve the project from existing entitlements and resources, or are new or expanded entitlements needed?	<input type="checkbox"/>	<input type="checkbox"/>	<input checked="" type="checkbox"/>	<input type="checkbox"/>
e) Result in a determination by the wastewater treatment provider, which serves or may serve the project that it has adequate capacity to serve the project's projected demand in addition to the provider's existing commitments?	<input type="checkbox"/>	<input type="checkbox"/>	<input checked="" type="checkbox"/>	<input type="checkbox"/>
f) Be served by a landfill with sufficient permitted capacity to accommodate the project's solid waste disposal needs?	<input type="checkbox"/>	<input type="checkbox"/>	<input checked="" type="checkbox"/>	<input type="checkbox"/>
g) Comply with federal, state, and local statutes and regulations related to solid waste?	<input type="checkbox"/>	<input type="checkbox"/>	<input type="checkbox"/>	<input checked="" type="checkbox"/>
<b>XVII. MANDATORY FINDINGS OF SIGNIFICANCE.</b>				
A) Does the project have the potential to degrade the quality of the environment, substantially reduce the habitat of a fish or wildlife species, cause a fish or wildlife population to drop below self-sustaining levels, threaten to eliminate a plant or animal community, reduce the number or restrict the range of a rare or endangered plant or animal or eliminate important examples of the major period of California history or prehistory?	<input type="checkbox"/>	<input checked="" type="checkbox"/>	<input type="checkbox"/>	<input type="checkbox"/>
b) Does the project have the potential to achieve short-term environmental goals to the disadvantage of long-term environmental goals?	<input type="checkbox"/>	<input type="checkbox"/>	<input type="checkbox"/>	<input checked="" type="checkbox"/>
c) Does the project have impacts that are individually limited, but cumulatively considerable? ("Cumulatively considerable" means that the incremental effects of a project are considerable when viewed in connection with the effects of past projects, the effects of other current projects, and the effects of probable future projects.)	<input type="checkbox"/>	<input type="checkbox"/>	<input type="checkbox"/>	<input checked="" type="checkbox"/>
d) Does the project have environmental effects which will cause substantial adverse effects on human beings, either directly or indirectly?	<input type="checkbox"/>	<input checked="" type="checkbox"/>	<input type="checkbox"/>	<input type="checkbox"/>



Linda S. Adams  
Secretary for  
Environmental Protection



## Department of Toxic Substances Control

Maziar Movassaghi, Acting Director  
5796 Corporate Avenue  
Cypress, California 90630

**RECEIVED**

FEB 25 7 00 AM



Arnold Schwarzenegger  
Governor

CITY OF DANA POINT  
COMMUNITY DEVELOPMENT  
DEPT. OF PLANNING

February 24, 2010

Ms. Saima Qureshy, AICP  
Senior Planner  
City of Dana Point  
33282 Golden Lantern  
Dana Point, California 92629-1805  
squireshy@danapoint.org

### NOTICE OF PREPARATION FOR A DRAFT ENVIRONMENTAL IMPACT REPORT FOR THE SOUTH SHORES CHURCH MASTER PLAN PROJECT (SCH# 2009041129), ORANGE COUNTY

Dear Ms. Qureshy:

The Department of Toxic Substances Control (DTSC) has received your submitted Notice of Preparation (NOP) for a draft Environmental Impact Report (EIR) for the above-mentioned project. The following project description is stated in your document: "The project site is located at 32712 Crown Valley Parkway and is adjacent to the intersection of Crown Valley Parkway and Sea Island Drive within the City of Dana Point. The project site is semi-rectangular in shape and comprises approximately 6 acres of land developed with South Shores Church facilities, all within the City's Coastal Zone. Existing conditions on the site include 42,545 square feet (sf) of building space including a Sanctuary, Chapel, Administrative and Fellowship Hall, Preschool, and associated parking. The proposed project includes demolition of approximately 23,467 sf of building area, including the existing Chapel, Administrative and Fellowship Hall, and Preschool, and construction of approximately 70,284 sf of new building area, including a new Preschool and Administrative Building, two Christian Education Buildings, and a Community Life Center, for a total of 89,362 sf of building area at the completion of the Master Plan. Additionally, the proposed project includes a two-level partially subterranean parking structure. The project site is bordered on the west by Crown Valley Parkway and residential uses beyond; on the north and south by residential uses; and on the east by an undeveloped slope and the Monarch Beach Golf Links beyond". DTSC has the following comments:

- 1) The EIR should identify the current or historic uses at the project site that may have resulted in a release of hazardous wastes/substances, and any known or potentially contaminated sites within the proposed Project area. For all identified

sites, the EIR should evaluate whether conditions at the site may pose a threat to human health or the environment. Following are the databases of some of the pertinent regulatory agencies:

- National Priorities List (NPL): A list maintained by the United States Environmental Protection Agency (U.S.EPA).
  - EnviroStor: A Database primarily used by the California Department of Toxic Substances Control, accessible through DTSC's website (see below).
  - Resource Conservation and Recovery Information System (RCRIS): A database of RCRA facilities that is maintained by U.S. EPA.
  - Comprehensive Environmental Response Compensation and Liability Information System (CERCLIS): A database of CERCLA sites that is maintained by U.S.EPA.
  - Solid Waste Information System (SWIS): A database provided by the California Integrated Waste Management Board which consists of both open as well as closed and inactive solid waste disposal facilities and transfer stations.
  - Leaking Underground Storage Tanks (LUST) / Spills, Leaks, Investigations and Cleanups (SLIC): A list that is maintained by Regional Water Quality Control Boards.
  - Local Counties and Cities maintain lists for hazardous substances cleanup sites and leaking underground storage tanks.
  - The United States Army Corps of Engineers, 911 Wilshire Boulevard, Los Angeles, California, 90017, (213) 452-3908, maintains a list of Formerly Used Defense Sites (FUDS).
- 2) The EIR should identify the mechanism to initiate any required investigation and/or remediation for any site that may be contaminated, and the government agency to provide appropriate regulatory oversight. If necessary, DTSC would require an oversight agreement in order to review such documents. Please see comment No.11 below for more information.
- 3) All environmental investigations, sampling and/or remediation for the site should be conducted under a Workplan approved and overseen by a regulatory agency that has jurisdiction to oversee hazardous substance cleanup. The findings of any investigations, including any Phase I or II Environmental Site Assessment Investigations should be summarized in the document. All sampling results in

which hazardous substances were found should be clearly summarized in a table.

- 4) Proper investigation, sampling and remedial actions overseen by the respective regulatory agencies, if necessary, should be conducted at the site prior to the new development or any construction. All closure, certification or remediation approval reports by these agencies should be included in the EIR.
- 5) If buildings or other structures, asphalt or concrete-paved surface areas are being planned to be demolished, an investigation should be conducted for the presence of other related hazardous chemicals, lead-based paints or products, mercury, and asbestos containing materials (ACMs). If other hazardous chemicals, lead-based paints or products, mercury or ACMs are identified, proper precautions should be taken during demolition activities. Additionally, the contaminants should be remediated in compliance with California environmental regulations and policies.
- 6) Project construction may require soil excavation or filling in certain areas. Sampling may be required. If soil is contaminated, it must be properly disposed and not simply placed in another location onsite. Land Disposal Restrictions (LDRs) may be applicable to such soils. Also, if the project proposes to import soil to backfill the areas excavated, sampling should be conducted to ensure that the imported soil is free of contamination.
- 7) Human health and the environment of sensitive receptors should be protected during the construction or demolition activities. If it is found necessary, a study of the site and a health risk assessment overseen and approved by the appropriate government agency and a qualified health risk assessor should be conducted to determine if there are, have been, or will be, any releases of hazardous materials that may pose a risk to human health or the environment.
- 8) If it is determined that hazardous wastes are, or will be, generated by the proposed operations, the wastes must be managed in accordance with the California Hazardous Waste Control Law (California Health and Safety Code, Division 20, Chapter 6.5) and the Hazardous Waste Control Regulations (California Code of Regulations, Title 22, Division 4.5). If it is determined that hazardous wastes will be generated, the facility should also obtain a United States Environmental Protection Agency Identification Number by contacting (800) 618-6942. Certain hazardous waste treatment processes or hazardous materials, handling, storage or uses may require authorization from the local Certified Unified Program Agency (CUPA). Information about the requirement for authorization can be obtained by contacting your local CUPA.

- 9) If during construction/demolition of the project, the soil and/or groundwater contamination is suspected, construction/demolition in the area should cease and appropriate health and safety procedures should be implemented.
- 10) DTSC can provide guidance for cleanup oversight through an Environmental Oversight Agreement (EOA) for government agencies that are not responsible parties under CERCLA, or a Voluntary Cleanup Agreement (VCA) for private parties. For additional information on the EOA or VCA, please see [www.dtsc.ca.gov/SiteCleanup/Brownfields](http://www.dtsc.ca.gov/SiteCleanup/Brownfields), or contact Ms. Maryam Tasnif-Abbasi, DTSC's Voluntary Cleanup Coordinator, at (714) 484-5489.

If you have any questions regarding this letter, please contact Mr. Rafiq Ahmed, Project Manager, at [rahmed@dtsc.ca.gov](mailto:rahmed@dtsc.ca.gov) or by phone at (714) 484-5491.

Sincerely,



Greg Holmes  
Unit Chief  
Brownfields and Environmental Restoration Program - Cypress Office

cc: Governor's Office of Planning and Research  
State Clearinghouse  
P.O. Box 3044  
Sacramento, California 95812-3044  
[state.clearinghouse@opr.ca.gov](mailto:state.clearinghouse@opr.ca.gov)

CEQA Tracking Center  
Department of Toxic Substances Control  
Office of Environmental Planning and Analysis  
1001 I Street, 22nd Floor, M.S. 22-2  
Sacramento, California 95814  
[ADelacr1@dtsc.ca.gov](mailto:ADelacr1@dtsc.ca.gov)

CEQA# 2815

**NATIVE AMERICAN HERITAGE COMMISSION**

915 CAPITOL MALL, ROOM 364  
SACRAMENTO, CA 95814  
(916) 653-6251  
Fax (916) 657-5390  
Web Site [www.nahc.ca.gov](http://www.nahc.ca.gov)  
e-mail: [ds\\_nahc@pacbell.net](mailto:ds_nahc@pacbell.net)



February 10, 2010

RECEIVED

FEB 10 2010

Ms. Saima Qureshy, AICP, Senior Planner

**CITY OF DANA POINT**

33282 Golden Lantern  
Dana Point, CA 92629

Re: SCH#2009041129 CEQA Notice of Preparation (NOP); draft Environmental Impact Report (DEIR) for the South Shores Church Master Plan.; located in the City of Dana Point, Orange, California

Dear Ms. Qureshy:

The Native American Heritage Commission (NAHC) is the state 'trustee agency' pursuant to Public Resources Code §21070 for the protection and preservation of California's Native American Cultural Resources.. (Also see *Environmental Protection Information Center v. Johnson* (1985) 170 Cal App. 3<sup>rd</sup> 604) The California Environmental Quality Act (CEQA - CA Public Resources Code §21000-21177, amended in 2009) requires that any project that causes a substantial adverse change in the significance of an historical resource, that includes archaeological resources, is a 'significant effect' requiring the preparation of an Environmental Impact Report (EIR) per the California Code of Regulations §15064.5(b)(c)(f) CEQA guidelines). Section 15382 of the CEQA Guidelines defines a significant impact on the environment as "a substantial, or potentially substantial, adverse change in any of physical conditions within an area affected by the proposed project, including ...objects of historic or aesthetic significance." In order to comply with this provision, the lead agency is required to assess whether the project will have an adverse impact on these resources within the 'area of potential effect (APE), and if so, to mitigate that effect. To adequately assess the project-related impacts on historical resources, the Commission recommends the following.

The Native American Heritage Commission did perform a Sacred Lands File (SLF) search in the NAHC SLF Inventory, established by the Legislature pursuant to Public Resources Code §5097.94(a) and Native American Cultural resources were not identified within the APE Early consultation with Native American tribes in your area is the best way to avoid unanticipated discoveries once a project is underway. Enclosed are the names of the nearest tribes and interested Native American individuals that the NAHC recommends as 'consulting parties,' for this purpose, that may have knowledge of the religious and cultural significance of the historic properties in the project area (e.g. APE). We recommend that you contact persons on the attached list of Native American contacts. A Native American Tribe or Tribal Elder may be the only source of information about a cultural resource.. Also, the NAHC recommends that a Native American Monitor or Native American culturally knowledgeable person be employed whenever a professional archaeologist is employed during the 'Initial Study' and in other phases of the environmental planning processes.. Furthermore we suggest that you contact the California Historic Resources Information System (CHRIS) at the Office of Historic Preservation (OHP) Coordinator's office (at (916) 653-7278, for referral to the nearest OHP Information Center of which there are 11.

Consultation with tribes and interested Native American tribes and interested Native American individuals, as consulting parties, on the NAHC list, should be conducted in compliance with the requirements of federal NEPA (42 U.S.C. 4321-43351) and Section 106 and 4(f) of federal NHPA (16 U.S.C. 470 [f] *et seq*), 36 CFR Part 800.3, the President's Council on Environmental Quality (CSQ; 42 U.S.C. 4371 *et seq*) and NAGPRA (25 U.S.C. 3001-3013), as appropriate. .

Lead agencies should consider avoidance, as defined in Section 15370 of the California Environmental Quality Act (CEQA) when significant cultural resources could be affected by a project. Also, Public Resources Code Section 5097.98 and Health & Safety Code Section 7050.5 provide for provisions for accidentally discovered archeological resources during construction and mandate the processes to be followed in the event of an accidental discovery of any human remains in a project location other than a 'dedicated cemetery. Discussion of these should be included in your environmental documents, as appropriate.

The authority for the SLF record search of the NAHC Sacred Lands Inventory, established by the California Legislature, is California Public Resources Code §5097.94(a) and is exempt from the CA Public Records Act (c.f. California Government Code §6254.10). The results of the SLF search are confidential. However, Native Americans on the attached contact list are not prohibited from and may wish to reveal the nature of identified cultural resources/historic properties. Confidentiality of "historic properties of religious and cultural significance' may also be protected the under Section 304 of the NHPA or at the Secretary of the Interior' discretion if not eligible for listing on the National Register of Historic Places. The Secretary may also be advised by the federal Indian Religious Freedom Act (cf. 42 U.S.C, 1996) in issuing a decision on whether or not to disclose items of religious and/or cultural significance identified in or near the APE and possibly threatened by proposed project activity.

CEQA Guidelines, Section 15064.5(d) requires the lead agency to work with the Native Americans identified by this Commission if the initial Study identifies the presence or likely presence of Native American human remains within the APE. CEQA Guidelines provide for agreements with Native American, identified by the NAHC, to assure the appropriate and dignified treatment of Native American human remains and any associated grave liens.

Health and Safety Code §7050.5, Public Resources Code §5097.98 and Sec. §15064.5 (d) of the California Code of Regulations (CEQA Guidelines) mandate procedures to be followed, including that construction or excavation be stopped in the event of an accidental discovery of any human remains in a location other than a dedicated cemetery until the county coroner or medical examiner can determine whether the remains are those of a Native American. . Note that §7052 of the Health & Safety Code states that disturbance of Native American cemeteries is a felony.

Again, Lead agencies should consider avoidance, as defined in §15370 of the California Code of Regulations (CEQA Guidelines), when significant cultural resources are discovered during the course of project planning and implementation

Please feel free to contact me at (916) 653-6251 if you have any questions.

Sincerely,

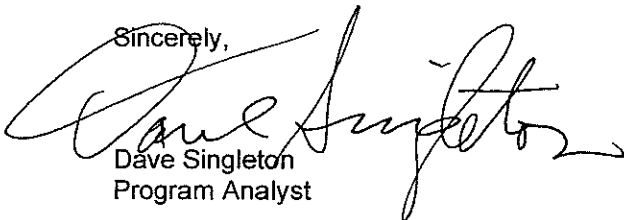

Dave Singleton  
Program Analyst

Attachment: List of Native American Contacts

Cc: State Clearinghouse

Native American Contacts  
Orange County  
February 10, 2010

Juaneno Band of Mission Indians Acjachemen Nation  
David Belardes, Chairperson  
32161 Avenida Los Amigos Juaneno  
San Juan Capistrano CA 92675  
DavidBelardes@hotmail.com  
(949) 293-8522  
(949) 493-4933 - Home

Juaneño Band of Mission Indians  
Sonia Johnston, Tribal Chairperson  
P.O. Box 25628 Juaneno  
Santa Ana , CA 92799  
sonia.johnston@sbcglobal.  
(714) 323-8312

Juaneno Band of Mission Indians Acjachemen Nation  
Anthony Rivera, Chairman  
31411-A La Matanza Street Juaneno  
San Juan Capistrano CA 92675-2674  
arivera@juaneno.com  
(949) 488-3484

Juaneno Band of Mission Indians  
Anita Espinoza  
1740 Concerto Drive Juaneno  
Anaheim , CA 92807  
(714) 779-8832

(530) 354-5876 - cell

Juaneno Band of Mission Indians  
Alfred Cruz, Culural Resources Coordinator  
P.O. Box 25628 Juaneno  
Santa Ana , CA 92799  
alfredgcruz@sbcglobal.net  
714-998-0721  
714-998-0721 - FAX  
714-321-1944 - cell

Juaneno Band of Mission Indians Acjachemen Nation  
Joyce Perry  
4955 Paseo Segovia Juaneno  
Irvine , CA 92612  
949-293-8522

Juaneno Band of Mission Indians  
Adolph 'Bud' Sepulveda, Vice Chairperson  
P.O. Box 25828 Juaneno  
Santa Ana , CA 92799  
bssepul@yahoo.net  
714-838-3270  
714-914-1812 - CELL  
bsepul@yahoo.net

This list is current only as of the date of this document.

Distribution of this list does not relieve any person of statutory responsibility as defined in Section 7050.5 of the Health and Safety Code, Section 5097.94 of the Public Resources Code and Section 5097.98 of the Public Resources Code. Also, federal National Environmental Policy Act (NEPA), National Historic Preservation Act, Section 106, and federal NAGPRA.

This list is only applicable for contacting local Native Americans with regard to cultural resources for the proposed SSCH#2009041129; CEQA Notice of Preparation (NOP); draft Environmental Impact Report (DEIR) for the South Shores Church Master Plan; located in the City of Dana Point; Orange County, California





# South Coast Air Quality Management District

21865 Copley Drive, Diamond Bar, CA 91765-4178  
(909) 396-2000 • www.aqmd.gov

February 24, 2010

RECEIVED

FEB 26 2010

CITY OF DANA POINT  
COMMUNITY DEVELOPMENT  
DEPARTMENT

Saima Qureshy, AICP, Senior Planner  
City of Dana Point  
33282 Golden Lantern  
Dana Point, CA 92629-1805

Dear Saima Qureshy:

## **Notice of Preparation of a Draft Environmental Impact Report (Draft EIR) for the South Shores Church Project**

The South Coast Air Quality Management District (SCAQMD) appreciates the opportunity to comment on the above-mentioned document. The SCAQMD's comments are recommendations regarding the analysis of potential air quality impacts from the proposed project that should be included in the draft environmental impact report (EIR). Please send the SCAQMD a copy of the Draft EIR upon its completion. **In addition, please send with the draft EIR all appendices or technical documents related to the air quality analysis and electronic versions of all air quality modeling and health risk assessment files. Electronic files include spreadsheets, database files, input files, output files, etc., and does not mean Adobe PDF files. Without all files and supporting air quality documentation, the SCAQMD will be unable to complete its review of the air quality analysis in a timely manner. Any delays in providing all supporting air quality documentation will require additional time for review beyond the end of the comment period.**

### **Air Quality Analysis**

The SCAQMD adopted its California Environmental Quality Act (CEQA) Air Quality Handbook in 1993 to assist other public agencies with the preparation of air quality analyses. The SCAQMD recommends that the Lead Agency use this Handbook as guidance when preparing its air quality analysis. Copies of the Handbook are available from the SCAQMD's Subscription Services Department by calling (909) 396-3720. Alternatively, the lead agency may wish to consider using the California Air Resources Board (CARB) approved URBEMIS 2007 Model. This model is available on the SCAQMD Website at: [www.urbemis.com](http://www.urbemis.com).

The Lead Agency should identify any potential adverse air quality impacts that could occur from all phases of the project and all air pollutant sources related to the project. Air quality impacts from both construction (including demolition, if any) and operations should be calculated. Construction-related air quality impacts typically include, but are not limited to, emissions from the use of heavy-duty equipment from grading, earth-loading/unloading, paving, architectural coatings, off-road mobile sources (e.g., heavy-duty construction equipment) and on-road mobile sources (e.g., construction worker vehicle trips, material transport trips). Operation-related air quality impacts may include, but are not limited to, emissions from stationary sources (e.g., boilers), area sources (e.g., solvents and coatings), and vehicular trips (e.g., on- and off-road tailpipe emissions and entrained dust). Air quality impacts from indirect sources, that is, sources that generate or attract vehicular trips should be included in the analysis.

The SCAQMD has developed a methodology for calculating PM<sub>2.5</sub> emissions from construction and operational activities and processes. In connection with developing PM<sub>2.5</sub> calculation methodologies, the SCAQMD has also developed both regional and localized significance thresholds. The SCAQMD requests that the lead agency quantify PM<sub>2.5</sub> emissions and compare the results to the recommended PM<sub>2.5</sub> significance thresholds. Guidance for calculating PM<sub>2.5</sub> emissions and PM<sub>2.5</sub> significance thresholds can be found at the following internet address: [http://www.aqmd.gov/ceqa/handbook/PM2\\_5/PM2\\_5.html](http://www.aqmd.gov/ceqa/handbook/PM2_5/PM2_5.html).

In addition to analyzing regional air quality impacts the SCAQMD recommends calculating localized air quality impacts and comparing the results to localized significance thresholds (LSTs). LST's can be used in addition to the recommended regional significance thresholds as a second indication of air quality impacts when preparing a CEQA document. Therefore, when preparing the air quality analysis for the proposed project, it is recommended that the lead agency perform a localized significance analysis by either using the LSTs developed by the SCAQMD or performing dispersion modeling as necessary. Guidance for performing a localized air quality analysis can be found at <http://www.aqmd.gov/ceqa/handbook/LST/LST.html>.

In the event that the proposed project generates or attracts vehicular trips, especially heavy-duty diesel-fueled vehicles, it is recommended that the lead agency perform a mobile source health risk assessment. Guidance for performing a mobile source health risk assessment ("Health Risk Assessment Guidance for Analyzing Cancer Risk from Mobile Source Diesel Idling Emissions for CEQA Air Quality Analysis") can be found on the SCAQMD's CEQA web pages at the following internet address: [http://www.aqmd.gov/ceqa/handbook/mobile\\_toxic/mobile\\_toxic.html](http://www.aqmd.gov/ceqa/handbook/mobile_toxic/mobile_toxic.html). An analysis of all toxic air contaminant impacts due to the decommissioning or use of equipment potentially generating such air pollutants should also be included.

### **Mitigation Measures**

In the event that the project generates significant adverse air quality impacts, CEQA requires that all feasible mitigation measures that go beyond what is required by law be utilized during project construction and operation to minimize or eliminate significant adverse air quality impacts. To assist the Lead Agency with identifying possible mitigation measures for the project, please refer to Chapter 11 of the SCAQMD CEQA Air Quality Handbook for sample air quality mitigation measures. Additional mitigation measures can be found on the SCAQMD's CEQA web pages at the following internet address: [www.aqmd.gov/ceqa/handbook/mitigation/MM\\_intro.html](http://www.aqmd.gov/ceqa/handbook/mitigation/MM_intro.html) Additionally, SCAQMD's Rule 403 – Fugitive Dust, and the Implementation Handbook contain numerous measures for controlling construction-related emissions that should be considered for use as CEQA mitigation if not otherwise required. Other measures to reduce air quality impacts from land use projects can be found in the SCAQMD's Guidance Document for Addressing Air Quality Issues in General Plans and Local Planning. This document can be found at the following internet address: <http://www.aqmd.gov/prdas/aqguide/aqguide.html>. In addition, guidance on siting incompatible land uses can be found in the California Air Resources Board's Air Quality and Land Use Handbook: A Community Perspective, which can be found at the following internet address: <http://www.arb.ca.gov/ch/handbook.pdf>. CARB's Land Use Handbook is a general reference guide for evaluating and reducing air pollution impacts associated with new projects that go through the land use decision-making process. Pursuant to state CEQA Guidelines §15126.4 (a)(1)(D), any impacts resulting from mitigation measures must also be discussed.

### **Data Sources**

SCAQMD rules and relevant air quality reports and data are available by calling the SCAQMD's Public Information Center at (909) 396-2039. Much of the information available through the Public Information Center is also available via the SCAQMD's World Wide Web Homepage (<http://www.aqmd.gov>).

The SCAQMD is willing to work with the Lead Agency to ensure that project-related emissions are accurately identified, categorized, and evaluated. Please call Ian MacMilian, Program Supervisor, CEQA Section, at (909) 396-3244 if you have any questions regarding this letter.

Sincerely,

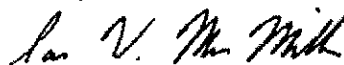

Ian MacMilian

Program Supervisor, CEQA Inter-Governmental Review  
Planning, Rule Development & Area Sources

IM:DG:AK

ORC100204-07AK

Control Number

**This page intentionally left blank**

## **APPENDIX B**

# **AIR QUALITY AND GREENHOUSE GAS ANALYSIS**

**This page intentionally left blank**

# AIR QUALITY ANALYSIS

SOUTH SHORES CHURCH MASTER PLAN  
CITY OF DANA POINT, CALIFORNIA

LSA

August 2014

# AIR QUALITY ANALYSIS

SOUTH SHORES CHURCH MASTER PLAN  
CITY OF DANA POINT, CALIFORNIA

Submitted to:

City of Dana Point  
33282 Golden Lantern, Suite 209  
Dana Point, California 92629

Prepared by:

LSA Associates, Inc.  
20 Executive Park, Suite 200  
Irvine, California 92614  
(949) 553-0666

Project No. DPC0902

LSA

August 2014

## TABLE OF CONTENTS

EXECUTIVE SUMMARY .....	1
PROJECT DESCRIPTION .....	3
INTRODUCTION.....	3
PROJECT DESCRIPTION .....	3
Project Location .....	3
Project Site Existing Setting.....	3
Surrounding Land Uses.....	5
Proposed Project.....	5
Completed Master Plan .....	11
SETTING .....	12
REGIONAL AIR QUALITY .....	12
Climate/Meteorology .....	15
Description of Global Climate Change and Its Sources.....	16
Emissions Sources and Inventories .....	20
Air Pollution Constituents and Attainment Status .....	21
LOCAL AIR QUALITY .....	24
REGULATORY SETTINGS .....	26
Federal Regulations/Standards.....	26
State Regulations/Standards.....	27
Regional Air Quality Planning Framework .....	30
Regional Air Quality Management Plan .....	31
THRESHOLDS OF SIGNIFICANCE .....	32
THRESHOLDS OF SIGNIFICANCE .....	32
Regional Thresholds for Construction Emissions.....	33
Regional Thresholds for Operational Emissions.....	33
Thresholds for Localized Impacts Analysis .....	34
Thresholds for Global Climate Change.....	35
IMPACTS AND MITIGATION .....	40
CONSTRUCTION IMPACTS.....	40
Equipment Exhausts and Related Construction Activities.....	40
Fugitive Dust.....	40
Architectural Coatings .....	44
Localized Impacts Analysis .....	44
Odors.....	44
Naturally Occurring Asbestos .....	45
Construction Emissions Conclusions.....	45
LONG-TERM REGIONAL AIR QUALITY IMPACTS .....	45
Long-Term Project Operational Emissions .....	45
Localized Impacts Analysis .....	45
Greenhouse Gas Emissions .....	47
LONG-TERM MICROSCALE (CO HOT SPOT) ANALYSIS.....	54
AIR QUALITY MANAGEMENT PLAN CONSISTENCY.....	55
STANDARD CONDITIONS .....	56
Construction Operations.....	56
Operations .....	56



PROJECT FEATURES .....	57
Global Climate Change Impacts .....	57
CUMULATIVE IMPACTS .....	58
IMPACTS TO THE PROPOSED PROJECT FROM GLOBAL CLIMATE CHANGE.....	58
REFERENCES .....	59

## FIGURES

Figure 1: Project Location Map.....	4
Figure 2: Proposed Master Plan .....	7

## TABLES

Table A: Existing Development .....	5
Table B: Existing On-Site Buildings.....	6
Table C: Proposed Master Plan Buildings.....	6
Table D: Ambient Air Quality Standards .....	13
Table E: Summary of Health Effects of the Major Criteria Air Pollutants .....	15
Table F: Global Warming Potential of Greenhouse Gases.....	18
Table G: Attainment Status of Criteria Pollutants in the South Coast Air Basin .....	22
Table H: Ambient Air Quality Monitored in the Project Vicinity .....	25
Table I: Construction Schedule .....	41
Table J: Diesel Construction Equipment Utilized by Construction Phase .....	42
Table K: Short-Term Regional Construction Emissions .....	43
Table L: Construction Localized Impacts Analysis .....	44
Table M: Regional Operational Emissions.....	46
Table N: Operational Localized Impacts Analysis.....	46
Table O: Peak Annual Construction GHG Emissions .....	49
Table P: Existing Operational Greenhouse Gas Emissions.....	50
Table Q: Long-Term Operational Greenhouse Gas Emissions .....	50
Table R: Project Compliance with Greenhouse Gas Emission Reduction Strategies .....	53

## APPENDIX

### A: CALEEMOD MODEL PRINTOUTS

## EXECUTIVE SUMMARY

LSA Associates, Inc. (LSA) was retained by the City of Dana Point (City) to prepare an air quality study for a proposed project located in the City of Dana Point in Orange County (County), California.

The air quality study provides a discussion of the proposed project, the physical setting of the project area, and the regulatory framework for air quality. The report provides data on existing air quality and evaluates potential air quality impacts associated with the proposed project. Modeled air quality levels are based upon default trip generation for the proposed uses included in the project.

Regional emissions during project construction, calculated with the CalEEMod (Version 2013.2.2) model, would not exceed criteria pollutant thresholds established by the South Coast Air Quality Management District (SCAQMD). Compliance with SCAQMD Rules and Regulations during construction will reduce construction-related air quality impacts from fugitive dust emissions and construction equipment emissions. Standard dust suppression measures have been identified for short-term construction to meet the SCAQMD emissions thresholds. The proposed project would not exceed the localized significance thresholds (LSTs).

Historical air quality data show that existing carbon monoxide (CO) levels for the project area and the general vicinity do not exceed either State or federal ambient air quality standards (AAQS). The CO concentrations in the project area are much lower than the federal and State CO standards. The proposed project would not result in any significant increase in CO concentrations at intersections in the project vicinity. Therefore, project-related traffic would not significantly affect local CO levels under future year conditions, and the CO concentrations would be below the State and federal standards. No significant impact on local CO levels would occur. Pollutant emissions from project operation, also calculated with the CalEEMod model, would not exceed the SCAQMD thresholds for any criteria pollutants. LSTs would not be exceeded by long-term emissions from the operation of the project.

The proposed project is located in Orange County, which is not among the counties that are found to have serpentine and ultramafic rock in their soils. In addition, no serpentine or ultramafic rock has been found in the project vicinity in the past 10 years. Therefore, the potential risk for naturally occurring asbestos (NOA) during project construction is small and less than significant.

The potential of the project to affect global climate change (GCC) is also included. Short-term construction and long-term operational emissions of the principal greenhouse gases (GHGs), including carbon dioxide (CO<sub>2</sub>) and methane (CH<sub>4</sub>), are quantified, and their significance relative to Assembly Bill (AB) 32 is discussed. The proposed project will not exceed any proposed GHG emissions thresholds or conflict with any applicable plan, policy, or regulation adopted for the purpose of reducing GHG emissions.

The proposed uses are consistent with the General Plan of the City, which is consistent with the Southern California Association of Governments (SCAG) Regional Comprehensive Plan (RCP) Guidelines and the SCAQMD *Air Quality Management Plan* (AQMP). Therefore, the proposed project is consistent with the General Plans and the regional AQMP.

The evaluation was prepared in conformance with appropriate standards, utilizing procedures and methodologies in the *SCAQMD California Environmental Quality Act (CEQA) Air Quality Handbook* (SCAQMD 1993) and associated updates. Air quality data posted on the California Air Resources Board (ARB) and United States Environmental Protection Agency (EPA) websites are included to document the local air quality environment.

## PROJECT DESCRIPTION

### INTRODUCTION

This air quality impact analysis has been prepared to evaluate the potential air quality impacts and mitigation measures associated with the proposed project in the City of Dana Point in Orange County, California. This report provides a project-specific air quality impact analysis by examining the impacts of the proposed uses on adjacent sensitive uses, as well as the impacts on the proposed uses on the project site, and evaluating the mitigation measures required as part of the project design. Guidelines identified by the SCAQMD in its *CEQA Air Quality Handbook* (SCAQMD, April 1993) and associated updates will be followed in this air quality impact analysis.

### PROJECT DESCRIPTION

#### Project Location

The project site is located at 32712 Crown Valley Parkway in the northern portion of the City. The site is bounded by Crown Valley Parkway to the west, the Monarch Bay Villas to the south, an undeveloped hillside and the Monarch Beach Golf Links golf course to the east, and the Monarch Coast Apartments to the north. The approximate 6-acre (ac) project site is generally rectangular in shape and is currently developed with the existing South Shores Church development. Refer to Figure 1 for the location of the project site.

#### Project Site Existing Setting

The existing church development includes a Sanctuary, Chapel, Administration and Fellowship Hall, Preschool, and parking lot. The 6,717-square-foot (sf) Preschool building is located in the northwestern part of the project site adjacent to Crown Valley Parkway. The children's play area is located southeast of the Preschool building and is surrounded by grass landscaping. The 12,985 sf Administration and Fellowship Hall building is located southeast of the playground, and the 3,765 sf Chapel is located southeast of the Administration and Fellowship Hall. The 19,078 sf Sanctuary is located in the central-eastern portion of the project site. An undeveloped slope descending from southwest to northeast is located on the northeastern boundary of the project site.